

—  
Made in Italy

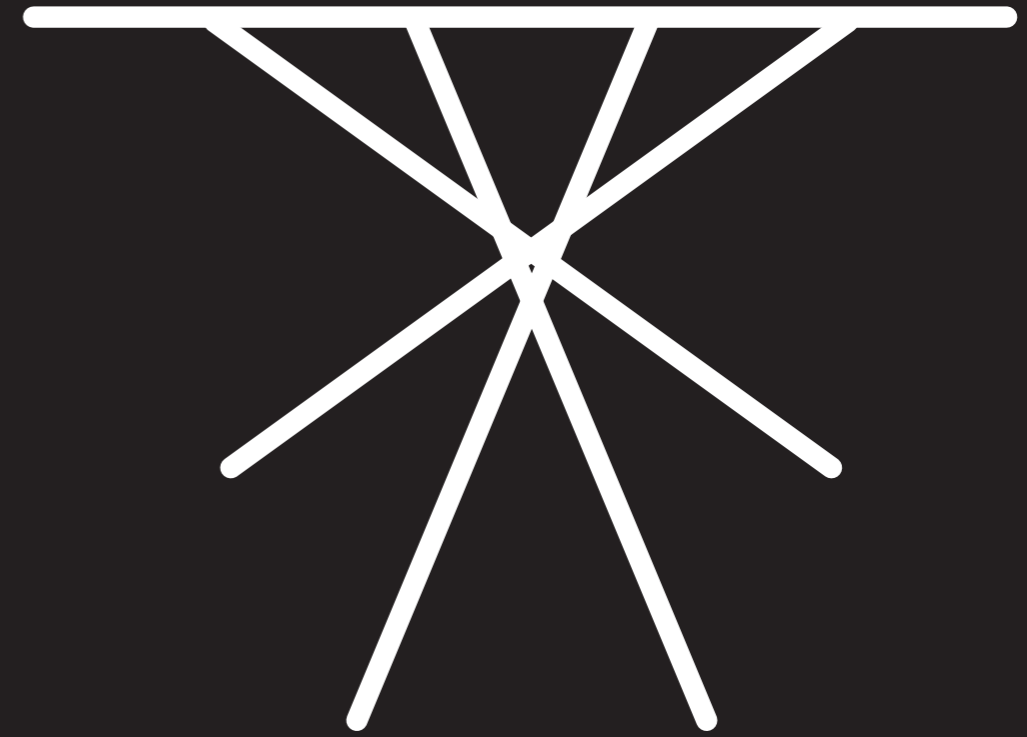

ALTACOM

ALTACOM srl  
Via Cavour, 2/a - 30024 Musile di Piave, VE Italy  
Tel. +39 0421 330311 Fax +39 0421 334007  
[www.altacomitalia.it](http://www.altacomitalia.it) [info@altacomitalia.it](mailto:info@altacomitalia.it)



ALTACOM



Made in Italy



**La forza dei prodotti Altacom sta nella loro capacità di evolversi e trasformarsi adattandosi in modo eccellente ai più diversi contesti abitativi, sia in termini di stile, sia nel sapersi adeguare allo spazio disponibile. La nuova collezione Altacom di tavolini trasformabili, consolle, tavoli e sedie propone un percorso dettato dalla ricerca progettuale in cui il design entra nel processo produttivo con determinazione. Un design che punta alla estrema funzionalità ed ergonomia con la cura e l'attenzione dell'artista che sceglie con sensibilità le forme, i materiali, le cromie e le finiture per dar vita a progetti esclusivi. La ricerca costante, la volontà di innovare e la passione che ci ha accompagnato sin dalla fine degli anni 80 produce giorno dopo giorno non semplici tavoli ma "piani intelligenti" capaci di muoversi nel cambiamento, prerogativa costante per il successo di un prodotto.**

La force des produits Altacom réside dans leur capacité à évoluer et se transformer, en s'adaptant parfaitement aux différents contextes de l'habitat, soit en termes de style, soit en sachant se conformer à l'espace disponible. La nouvelle collection Altacom de tables relevables, consoles extensibles, tables repas et chaises propose un itinéraire dicté par la recherche conceptuelle où le design rentre dans le processus de production avec détermination. Un design visant à la fonctionnalité extrême et à l'ergonomie, avec les soins et l'attention de l'artiste qui sait choisir avec sensibilité les formes, les matériaux, les couleurs et les finitions pour créer des projets exclusifs. La recherche constante, la volonté d'innover et la passion qui nous a accompagné des années 80 produit, jour après jour, non simplement de tables mais de «surfaces intelligentes» capables de se déplacer dans le changement, prérogative constante à la réussite d'un produit.

The strength of Altacom's products is in their skill to evolve and transform, adapting to the most various living contexts, both in terms of style and as capability to comply with the space available. The new Altacom collection of transforming tables, extending console-tables, dining tables and chairs is proposing an itinerary dictated by the projectual research where the design enters the production process with determination. A design focusing on extreme functionality and ergonomics, with the care and attention of the artist who can choose with sensibility the shapes, materials, colours and finishes to create exclusive projects. The constant research, the desire to innovate, and the passion that have been accompanying us since the mid-80s, day-by-day do not produce simple tables but "intelligent surfaces" capable of moving within change, a constant prerogative for the success of a product.



**TAVOLI  
TRASFORMABILI**

<sup>05</sup> <u>ARES BOOK</u> 40/47	<sup>16</sup> <u>ETOILE</u> 132/139
<sup>01</sup> <u>ARES FOLD</u> 08/15	<sup>17</sup> <u>GENIALE</u> 140/145
<sup>04</sup> <u>ARES GLASS</u> 32/39	<sup>14</sup> <u>GINGILLO</u> 118/125
<sup>02</sup> <u>ARES MEGA</u> 16/23	<sup>06</sup> <u>HELIOS</u> 48/55
<sup>03</sup> <u>ARES MOTORIUS</u> 24/31	<sup>09</sup> <u>ICARO</u> 74/81
<sup>12</sup> <u>ASSIST</u> 102/111	<sup>07</sup> <u>LEVANTE</u> 56/63
<sup>15</sup> <u>BESSY</u> 126/131	<sup>22</sup> <u>REDONDO</u> 178/185
<sup>19</sup> <u>CARRONDE</u> 154/161	<sup>20</sup> <u>SAKURA</u> 162/169
<sup>18</sup> <u>CIAK</u> 146/153	<sup>08</sup> <u>TAVOLETTO</u> 64/73
<sup>11</sup> <u>COMPACT</u> 94/101	<sup>10</sup> <u>ULISSE</u> 82/93
<sup>13</sup> <u>DOUBLE</u> 112/117	<sup>21</sup> <u>UNIVERSE</u> 170/177

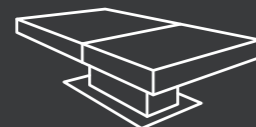

**CONSOLLE  
ESTENSIBILI**

<sup>25</sup> <u>ASTORIA</u> 206/215
<sup>29</sup> <u>COMBI</u> 240/247
<sup>23</sup> <u>DAVINCI</u> 186/195
<sup>31</sup> <u>FLAP</u> 256/263
<sup>24</sup> <u>GENESI</u> 196/205
<sup>28</sup> <u>LOBBY</u> 232/239
<sup>27</sup> <u>QUAD</u> 240/247
<sup>30</sup> <u>SQUARE</u> 248/255
<sup>26</sup> <u>TREK</u> 216/223



**TAVOLI  
DA PRANZO**

<sup>34</sup> <u>ARGON</u> 282/289
<sup>40</sup> <u>BASIC</u> 326/331
<sup>32</sup> <u>FAHRENHEIT</u> 264/275
<sup>33</sup> <u>FAHRENHEIT ROUND</u> 276/281
<sup>38</sup> <u>ICEBERG</u> 312/317
<sup>37</sup> <u>MERIDIANO</u> 306/311
<sup>41</sup> <u>SLALOM</u> 332/337
<sup>39</sup> <u>STORM</u> 318/325
<sup>36</sup> <u>SUN</u> 298/305
<sup>35</sup> <u>TEOREMA</u> 290/297
<sup>42</sup> <u>TOWER MAXI</u> 338/345



**TAVOLINI  
& SGABELLI**

<sup>43</sup> <u>CENTER</u> 348/351
<sup>46</sup> <u>DROP</u> 352/357
<sup>48</sup> <u>ITACA</u> 358/361
<sup>45</sup> <u>OUTLINE</u> 352/356
<sup>44</sup> <u>PROFILO</u> 348/351



**SEDIE**

<sup>51</sup> <u>DANDY</u> 364
<sup>53</sup> <u>ERICA</u> 366/367
<sup>57</sup> <u>FABIA</u> 371
<sup>54</sup> <u>HIPPO</u> 368
<sup>50</sup> <u>MARIANNA</u> 363
<sup>52</sup> <u>MOLLY</u> 365
<sup>49</sup> <u>NANETTE</u> 362
<sup>56</sup> <u>NORMA</u> 370
<sup>55</sup> <u>VESTA</u> 369

**MATERIALI**

<sup>58</sup> <u>FINITURE</u> 372/381
--



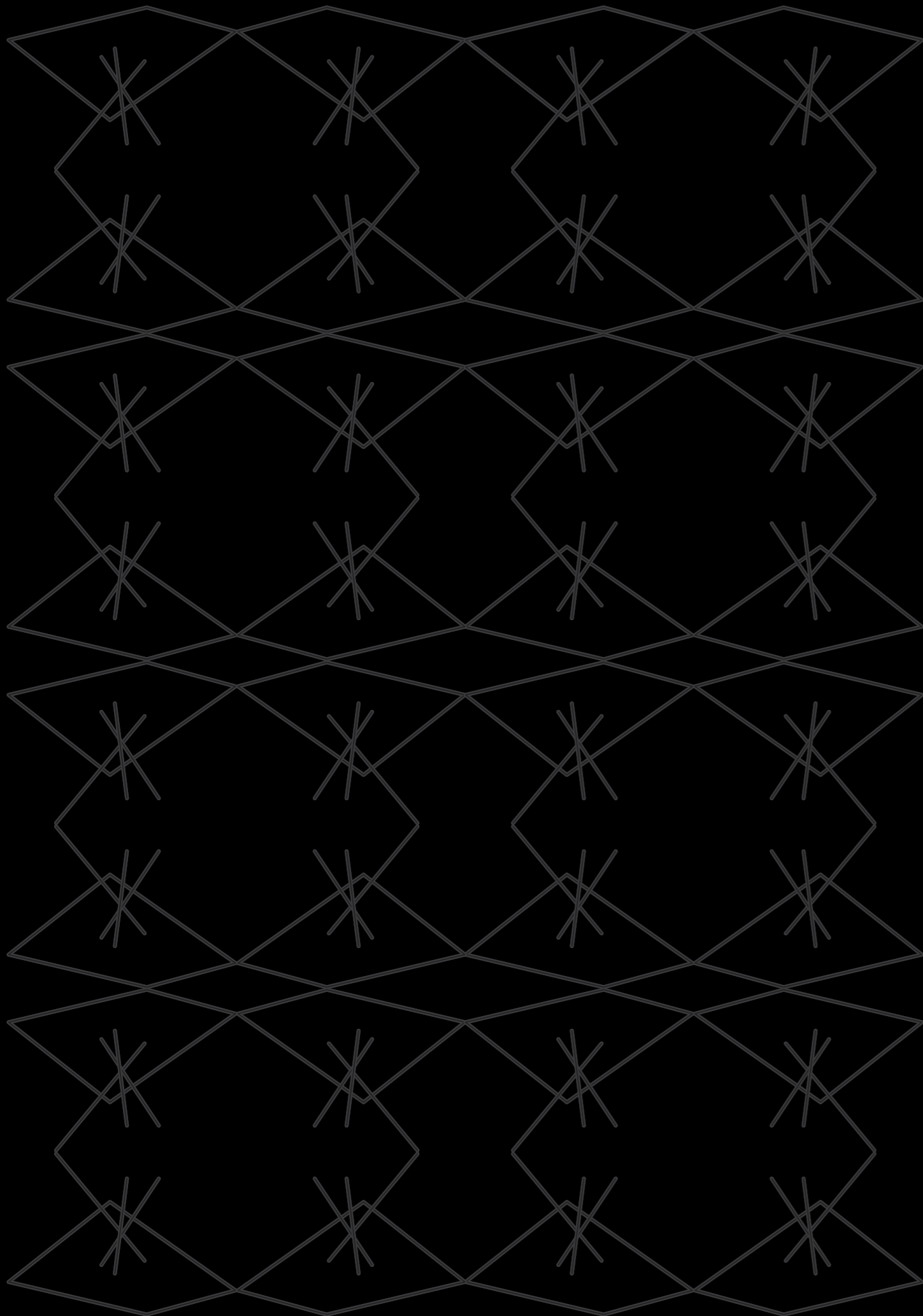

**ALTACOM, IL "FARE" E L'ORIGINALITÀ DEL "MADE IN ITALY".  
ALTACOM, LE "SAVOIR-FAIRE" ET L'ORIGINALITÉ DU "MADE IN ITALY".  
ALTACOM, PRAGMATIC SPIRIT AND THE ORIGINALITY OF THE "MADE IN ITALY".**

---

**Comprendere il movimento, il meccanismo attraverso cui un oggetto può trasformarsi da consolle a tavolo di 3 metri è il frutto di una ricerca costante, di profonde conoscenze tecnico-costruttive ed è alla base di ciascun prodotto Altacom. Se la funzionalità e la semplicità di utilizzo sono determinanti per il successo di un prodotto, altrettanto lo è la capacità "inventiva e interpretativa": ed è questo che fa la differenza tra un oggetto d'arredo qualunque e quello pensato per voi. Altacom realizza i suoi prodotti per voi, e non per un generico mercato del mobile di complemento: lo fa poiché la sua vocazione è ispirata dal "saper fare" dell'artigiano che sperimenta e produce mettendoci mano, cervello ed elevata tecnologia senza distinzione, facendo nascere da questo connubio le idee migliori, quelle che ci hanno portato ad essere produttori appassionati, partner affidabili, cultori di un design made in Italy applicato alla funzione. Altacom, "versatili" per vocazione.**

Comprendre le mouvement, le mécanisme par lequel un objet peut se transformer de simple console à table de repas de 3 mètres est le résultat d'une recherche constante, de profonde connaissance technique-constructive et c'est la base de chaque produit Altacom. Si la fonctionnalité et la facilité d'utilisation sont cruciales pour le succès d'un produit, également on peut dire pour la capacité « inventive et d'interprétation », qui est ce qui fait la différence entre un meuble quelconque et un pensé pour vous. Altacom fabrique ses produits pour vous, et non pour un marché du meuble générique: on le fait parce que notre vocation est inspirée par le « savoir-faire » de l'artisan qui expérimente et produit en y mettant mains, cerveau et technologies à l'avant-garde sans distinction, ce qui fait naître de ce mariage les meilleures idées, celles qui nous ont amenés à être des producteurs passionnés, des partenaires fiables, des amateurs du design italien appliqué à la fonction. Altacom, "versatiles" par vocation.

Understanding the movement, the mechanism through which an object can be transformed from a simple console to a 3 meters' dining table is the result of constant research, profound technical and constructive knowledge and is the basis of each Altacom product. If functionality and easiness of use are crucial to the success of a product, so is the "inventive and interpretative" ability and this is what makes the difference between any piece of furniture and what is designed for you. Altacom makes its products for you, not for a generic furnishing market: we do so because our vocation is inspired by the "know-how" of the artisan who experiences and produces by putting hands, brain and high technology without distinction, originating from this union the best ideas, the ones having led us to be passionate producers, reliable partners, enthusiasts of a "made in Italy" design applied to the function. Altacom, "versatile" by vocation.

# ARES FOLD



MODERNO, FUORI DAL COMUNE, DOTATO DI UN BASAMENTO INSOLITO CHE ATTIRA SUBITO L'ATTENZIONE: ARES FOLD È IL TAVOLINO DA SALOTTO CHE DIVENTA TAVOLO DA PRANZO, PENSATO APPOSTA PER STUPIRE. SI ADATTA FACILMENTE A UN ARREDAMENTO MINIMAL, MA SALTA SUBITO ALL'OCCHIO ANCHE QUANDO È INSERITO IN UNA STANZA PIÙ INFORMALE E VISSUTA.

Moderne, hors de l'ordinaire, avec un piétement qui attire immédiatement l'attention: Ares Fold est une table relevable en table de repas, expressément conçue pour étonner. Cette table s'intègre parfaitement dans un décor minimal et essentiel, mais elle attire l'attention aussi dans un contexte plus informel et chaleureux.

Innovative, out of the box, with an unusual base which immediately catches attention: Ares Fold is a coffee table which transforms into a dining table. It has been thought to amaze. It adapts easily to a minimalist interior design but it immediately stands out even in informal rooms.



Base/Piètement/Base: verniciato grafite gofrato M11  
Piano/Plateau/Top: effetto malta metalli vissuti rame E05

01

**ARES FOLD**  
design Altacom

A R E S F O L D



01  
**ARES FOLD**  
design Altacom

ARES FOLD



01

**ARES FOLD**  
design Altacom

# A R E S F O L D



## FINITURE PIANO FINITIONS PLATEAU TOP FINISHES

### NOBILITATO / MÉLAMINE / MELAMINE

N05	Bianco matrix
N20	Natural halifax oak
N21	Pino jackson
N23	Cemento
N24	Ardesia
N25	Vintage chiaro
N30	Morera
N33	Resina silver
N34	Resina grigio cenere
N35	Rovere nodato caramel
N36	Olmo moka

### LACCATO / LAQUÉ / LACQUERED

### ROVERE IMPIALLACCIATO / PLACAGE CHÊNE / OAK VENEER

W01	Rovere naturale
W02	Rovere grigio
W03	Rovere tabacco
W04	Rovere nodato
W06	Rovere juta
W07	Rovere fumé

### CERAMICA / CÉRAMIQUE / CERAMIC

K01	Fokos sale
K02	Fokos terra
K03	Fokos piombo
K04	Noir desir lucido
K05	Bianco statuario venato lucido

LAMINAM®

### LEGNO MASSICCIO / BOISS MASSIF / SOLID WOOD

W21	Rovere vecchio massiccio termotrattato
W32	Rovere vecchio massiccio naturale
W33	Rovere vecchio massiccio grigio
W34	Larice fresato

### Poroso aperto / Pores ouverts / Open pore

L31
L32
L33
L34
L35
L39
L40

### Opaco / Mat / Matt

L51
L52
L53
L54
L55
L59
L60

### Lucido / Brilliant / High gloss

L01
-----

### EFFETTO MALTA / EFFET-BÉTON / MORTAR-LOOK

E01	Corten black
E02	Corten gold
E03	Corten silver
E04	Metalli vissuti nichel
E05	Metalli vissuti rame
E06	Beton tortora
E07	Beton nero
E08	Beton grigio scuro
E09	Beton grigio chiaro
E10	Pietra spatolata tortora
E11	Pietra spatolata notte
E12	Pietra spatolata cenere
E13	Pietra spatolata perla
E14	Pietra spatolata antracite
E15	Pietra spatolata travertino
E17	Pietra spatolata ardesia alluminio
E19	Bianco assoluto

Tavolino trasformabile in tavolo da pranzo, struttura centrale in acciaio, meccanismo a gas o elettrico a batteria ricaricabile, regolabile in altezza al millimetro da cm 41 a cm 82, piano rettangolare nobilitato, laccato, legno, effetto malta o ceramica, 2 prolunghe interne. Rotelle piroettanti a scomparsa. Brevettato.

Table relevable en table de repas, piètement central en acier, haussement par vérin-gaz ou électrique à batterie rechargeable, réglable en hauteur au millimètre de cm 41 à cm 82, plateau rectangulaire en mélamine, laqué, bois, effet-béton ou céramique, 2 rallonges internes. Roulettes cachées sous-piètement. Breveté.

Transforming coffee table which turns into a dining table, steel central column, gas or electric with rechargeable battery lifting device. Millimetre-adjustable height from cm 41 to cm 82, melamine, lacquered, stained wood, mortar-look or ceramic rectangular top, 2 inside extensions. Hidden under-plate castors. Patented.

## FINITURE BASE FINITIONS PIÉTEMENT BASE FINISHES

### METALLO / MÉTAUX / METALS

M01	Inox
M02	Verniciato grisou goffrato
M03	Verniciato bianco opaco
M04	Verniciato nero opaco
M11	Verniciato grafite goffrato
M12	Verniciato tortora opaco
M19	Verniciato bronzo goffrato

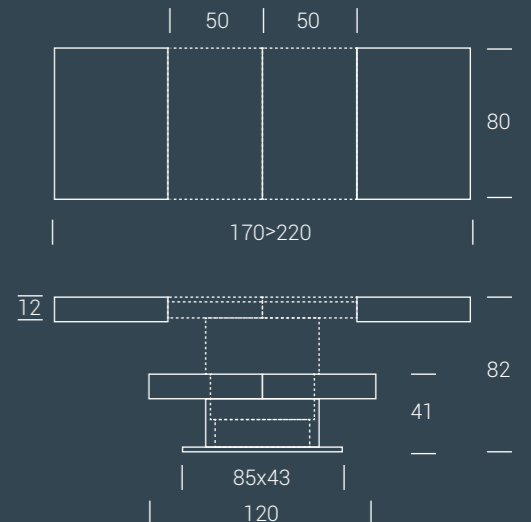



# A R E S M E G A

ARES MEGA É IL TRASFORMABILE PER ECCELLENZA, DOTATO DI UNA STRUTTURA CENTRALE IN INOX REGOLABILE IN ALTEZZA SI PRESTA AD ARREDARE L'AREA SALOTTO E LA ZONA PRANZO. IL PIANO AD ALTO SPESSORE, CONTENENTE IL MECCANISMO A GAS, SI INNALZA AL CENTRO STANZA COME UNA SCULTURA MODERNA PER ESSERE APPREZZATA DAL PUBBLICO.

Ares mega est la table relevable par excellence, avec sa structure inox réglable en hauteur, parfaite pour agencer un salon ou une salle à manger. Son plateau, de forte épaisseur cachant une mécanique à vérin gaz, s'élève au milieu de la pièce comme une sculpture moderne à être appréciée par le public.

Ares mega is the transforming table par excellence: with a central height-adjustable inox column it's perfect to furnish both a living and a dining room. Its high thickness top containing the gas lifting mechanism is elevating in the middle of the room as a modern sculpture to be appreciated by the public.



02

**ARES MEGA**  
design Altacom

**Base/Piédement/Base:** inox M01  
**Piano/Plateau/Top:** effetto malta metalli vissuti nichel E04

A R E S M E G A



02  
**A R E S M E G A**  
design Altacom

A R E S M E G A



02

**A R E S M E G A**  
design Altacom



**Tavolino trasformabile in tavolo da pranzo, struttura centrale in acciaio, meccanismo a gas o elettrico a batteria ricaricabile, regolabile in altezza da cm 41 a cm 76, piano in nobilitato, laccato, legno, effetto malta o ceramica, 2 prolunghe interne e 2 prolunghe esterne. Rotelle piroettanti a scomparsa. Gambe pieghevoli di supporto. Brevettato.**

Table relevable en table de repas, piétement central en acier, haussement par vérin-gaz ou électrique à batterie rechargeable, réglable en hauteur au millimètre de cm 41 à cm 76, plateau rectangulaire en mélamine, laqué, bois, effet-béton ou céramique, 2 rallonges internes plus 2 rallonges à part, pieds pliables à support des rallonges. Roulettes cachées sous piétement. Breveté.

Transforming coffee table, it turns into a dining table, steel central column, gas or electric with rechargeable battery lifting device. Millimetre-adjustable height from cm 41 to cm 76, melamine, lacquered, wood, mortar-look or ceramic rectangular top, 2 inside extensions and 2 external extensions. Hidden under-plate castors. Supporting folding legs. Patented.

**FINITURE PIANO**  
**FINITIONS PLATEAU**  
**TOP FINISHES**

**NOBILITATO**  
**/ MÉLAMINE**  
**/ MELAMINE**

- N05 Bianco matrix
- N20 Natural halifax oak
- N21 Pino jackson
- N23 Cemento
- N24 Ardesia
- N25 Vintage chiaro
- N30 Morera
- N33 Resina silver
- N34 Resina grigio cenere
- N35 Rovere nodato caramel
- N36 Olmo moka

**LACCATO**  
**/ LAQUÉ**  
**/ LACQUERED**

Poroso aperto  
/ Pores ouverts / Open pore

Opaco  
/ Mat / Matt

Lucido  
/ Brilliant / High gloss

- |     |     |     |                |
|-----|-----|-----|----------------|
| L31 | L51 | L01 | Bianco luce    |
| L32 | L52 |     | Bianco panna   |
| L33 | L53 |     | Bianco vela    |
| L34 | L54 |     | Grigio corda   |
| L35 | L55 |     | Grigio canapa  |
| L39 | L59 |     | Rosso aragosta |
| L40 | L60 |     | Tortora        |

**ROVERE IMPIALLACCIATO**  
**/ PLACAGE CHÊNE**  
**/ OAK VENEER**

- W01 Rovere naturale
- W02 Rovere grigio
- W03 Rovere tabacco
- W04 Rovere nodato
- W06 Rovere juta
- W07 Rovere fumé

**LEGNO MASSICCIO**  
**/ BOISS MASSIF**  
**/ SOLID WOOD**

- W21 Rovere vecchio massiccio termotrattato
- W32 Rovere vecchio massiccio naturale
- W33 Rovere vecchio massiccio grigio
- W34 Larice fresato

**EFFETTO MALTA**  
**/ EFFET-BÉTON**  
**/ MORTAR-LOOK**

- E01 Corten black
- E02 Corten gold
- E03 Corten silver
- E04 Metalli vissuti nichel
- E05 Metalli vissuti rame
- E06 Beton tortora
- E07 Beton nero
- E08 Beton grigio scuro
- E09 Beton grigio chiaro
- E10 Pietra spatolata tortora
- E11 Pietra spatolata notte
- E12 Pietra spatolata cenere
- E13 Pietra spatolata perla
- E14 Pietra spatolata antracite
- E15 Pietra spatolata travertino
- E17 Pietra spatolata ardesia alluminio
- E19 Bianco assoluto

**CERAMICA**  
**/ CÉRAMIQUE / CERAMIC**

- K01 Fokos sale
- K02 Fokos terra
- K03 Fokos piombo
- K04 Noir desir lucido
- K05 Bianco statuario venato lucido

**FINITURE BASE**  
**FINITIONS PIÉTEMENT**  
**BASE FINISHES**

**METALLO**  
**/ MÉTAUX**  
**/ METALS**

- M01 Inox
- M02 Verniciato grisou goffrato
- M03 Verniciato bianco opaco
- M04 Verniciato nero opaco
- M11 Verniciato grafite goffrato
- M12 Verniciato tortora opaco
- M19 Verniciato bronzo goffrato

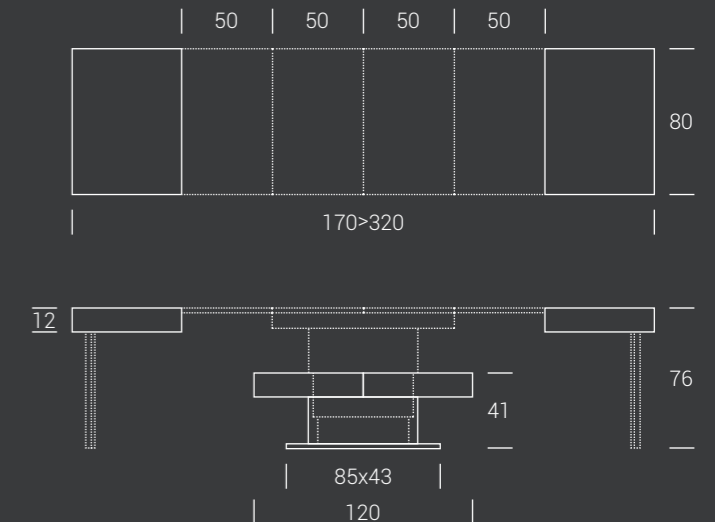

# ARES MOTORIUS

MOVIMENTO RAPIDO, PER CHI AMA LA PRATICITÀ, SENZA MAI RINUNCIARE AL GUSTO: LA VERSIONE DA SOGGIORNO DI ARES MOTORIUS SI TRASFORMA IN POCHI SECONDI IN UN TAVOLO DA PRANZO MOLTO ELEGANTE E GRADEVOLE. LA SUA ESTREMA DINAMICITÀ LO RENDE SEMPLICEMENTE PERFETTO PER CHI CHIEDE A UN COMPLEMENTO D'ARREDO GRANDE FACILITÀ DI UTILIZZO.

Fonction intelligente et rapide, pour ceux qui aiment la praticité, sans renoncer au goût: Ares Motorius se transforme dans quelques secondes en une table de repas belle et élégante. Sa grande fonctionnalité rend cette pièce simplement parfaite pour ceux qui recherchent et veulent la facilité d'utilisation.

Rapid movement, for those who love practicality without renouncing to style: Ares Motorius transforms into an elegant dining table in a few seconds. The extreme dynamism makes it perfect for people looking for a user friendly furniture.



03

**ARES MOTORIUS**  
design Altacom

Base/Piédement/Base: verniciato nero opaco M04  
Piano/Plateau/Top: nobilitato natural halifax oak N20

ARES MOTORIUS





03

ARES MOTORIUS  
design Altacom

# A R E S M O T O R I U S



## FINITURE PIANO FINITIONS PLATEAU TOP FINISHES

### NOBILITATO / MÉLAMINE / MELAMINE

- N05 Bianco matrix
- N20 Natural halifax oak
- N21 Pino jackson
- N23 Cemento
- N24 Ardesia
- N25 Vintage chiaro
- N30 Morera
- N33 Resina silver
- N34 Resina grigio cenere
- N35 Rovere nodato caramel
- N36 Olmo moka

### LACCATO / LAQUÉ / LACQUERED

Poros aperto  
/ Pores ouverts / Open pore

- L31 Bianco luce
- L32 Bianco panna
- L33 Bianco vela
- L34 Grigio corda
- L35 Grigio canapa
- L39 Rosso aragosta
- L40 Tortora

### ROVERE IMPIALLACCIATO / PLACAGE CHÊNE / OAK VENEER

- W01 Rovere naturale
- W02 Rovere grigio
- W03 Rovere tabacco
- W04 Rovere nodato
- W06 Rovere juta
- W07 Rovere fumé

### LEGNO MASSICCIO / BOISS MASSIF / SOLID WOOD

- W21 Rovere vecchio  
massiccio termotrattato
- W32 Rovere vecchio  
massiccio naturale
- W33 Rovere vecchio  
massiccio grigio
- W34 Larice fresato

### EFFETTO MALTA / EFFET BÉTON / MORTAR LOOK

- E01 Corten black
- E02 Corten gold
- E03 Corten silver
- E04 Metalli vissuti nichel
- E05 Metalli vissuti rame
- E06 Beton tortora
- E07 Beton nero
- E08 Beton grigio scuro
- E09 Beton grigio chiaro
- E10 Pietra spatolata tortora
- E11 Pietra spatolata notte
- E12 Pietra spatolata cenere
- E13 Pietra spatolata perla
- E14 Pietra spatolata antracite
- E15 Pietra spatolata travertino
- E17 Pietra spatolata ardesia alluminio
- E19 Bianco assoluto

**Tavolino trasformabile in tavolo da pranzo, struttura centrale in acciaio, meccanismo a gas o elettrico a batteria ricaricabile, regolabile in altezza al millimetro da cm 42 a cm 83, piano rettangolare in nobilitato, laccato, legno o effetto malta, con 2 prolunghe interne a libro coordinate al piano. Rotelle piroettanti a scomparsa. Brevettato.**

Table relevable en table de repas, piétement central en acier, haussement par vérin-gaz ou électrique à batterie rechargeable, réglable en hauteur au millimètre de cm 42 à cm 83, plateau rectangulaire en mélamine, laqué, bois ou effet-béton, avec 2 rallonges intégrées à portefeuille coordonnées au plateau. Roulettes cachées sous-piètement. Breveté.

Transforming coffee table, it turns into a dining table, steel central column, gas or electric with rechargeable battery lifting device. Millimetre-adjustable height from cm 42 to cm 83, melamine, lacquered, stained wood or mortar-look rectangular top, with 2 inside folded extensions matching top finishing. Hidden under-plate castors. Patented.

## FINITURE BASE FINITIONS PIÉTEMENT BASE FINISHES

### METALLO / MÉTAUX / METALS

- M01 Inox
- M02 Verniciato grisou goffrato
- M03 Verniciato bianco opaco
- M04 Verniciato nero opaco
- M11 Verniciato grafite goffrato
- M12 Verniciato tortora opaco
- M19 Verniciato bronzo goffrato

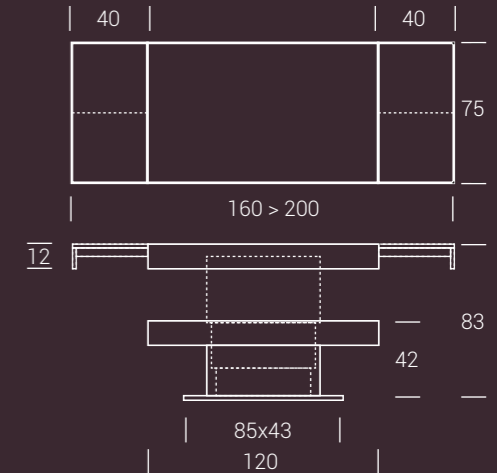



# ARES GLASS

UN TAVOLINO CHE RACCHIUDE IN SÉ UNO SPIRITO COSMOPOLITA, UN'ANIMA ANTI-CONFORMISTA E UN MIX DI SFACCETTATURE CHE LO RENDONO STRAORDINARIAMENTE SPECIALE. IL MIX DI MATERIALI DIVERSI E SOLO APPARENTEMENTE IN CONTRASTO, CREA IN REALTÀ UN CONNUBIO PERFETTO. ACCIAIO E VETRO COESISTONO DANDO VITA A UN'ARMONIA UNICA, SOFISTICATA.

Une table qui a un esprit cosmopolite, une âme non conventionnelle et un mix des détails: voilà les particularités qui rendent spéciale cette table. Différents matériaux, qui sont apparemment en contraste, mais qui, au contraire, créent une symbiose parfaite. Acier et verre coexistent, en produisant une harmonie unique et subtile.

A table that embodies a cosmopolitan spirit, a nonconformist soul and a mix of facets which makes it special. The mixing of different materials is just an illusory contrast, that indeed creates a perfect match. Steel and glass coexist in harmony creating a sophisticated atmosphere.



04

**ARES GLASS**  
design Altacom

Base/Piédement/Base: verniciato grisou goffrato M02  
Piano/Plateau/Top: vetro tortora acidato G05



A R E S   G L A S S



04

**A R E S   G L A S S**  
design Altacom

## A R E S G L A S S



### FINITURE PIANO FINITIONS PLATEAU TOP FINISHES

#### VETRO / VERRE / GLASS

G01	Bianco
G02	Tortora
G03	Nero
G04	Bianco acidato
G05	Tortora acidato
G06	Nero acidato

#### CERAMICA / CÉRAMIQUE / CERAMIC

K01	Fokos sale
K02	Fokos terra
K03	Fokos piombo
K04	Noir desir lucido
K05	Bianco statuario venato lucido

**LAMINAM**

**Tavolino trasformabile in tavolo da pranzo, struttura centrale in acciaio, meccanismo a gas o elettrico a batteria ricaricabile, regolabile in altezza al millimetro da cm 40 a cm 81, piano in vetro o ceramica, allunghe laterali a libro in nobilitato. Rotelle piroettanti a scomparsa. Brevettato.**

Table relevable en table de repas, piètement central en acier,haussement par vérin-gaz ou électrique à batterie rechargeable, réglable en hauteur au millimètre de cm 40 à cm 81, plateau verre ou céramique, rallonges latérales à portefeuille en mélamine. Roulettes cachées sous-piètement. Breveté.

Transforming coffee table, it turns into a dining table, steel central column, gas or electric with rechargeable battery lifting device. Millimetre adjustable height from cm 40 to cm 81, glass or ceramic top, side sliding folded extensions in melamine. Hidden under-plate castors. Patented.

### FINITURE BASE FINITIONS PIÉTEMENT BASE FINISHES

#### METALLO / MÉTAUX / METALS

M01	Inox
M02	Verniciato grisou goffrato
M03	Verniciato bianco opaco
M04	Verniciato nero opaco
M11	Verniciato grafite goffrato
M12	Verniciato tortora opaco
M19	Verniciato bronzo goffrato

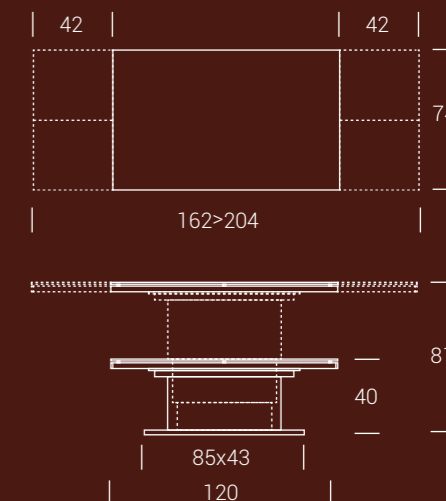

# A R E S B O O K

POCO SPAZIO A DISPOSIZIONE, VOGLIA DI SEMPLICITÀ ESTETICA ED ESTREMA FACILITÀ DI UTILIZZO: QUESTE LE TRE GRANDI ESIGENZE PIENAMENTE SODDISFATTE DA ARES BOOK. TRASFORMARE QUESTO TAVOLINO È FACILE COME APRIRE E SFOGLIARE UN LIBRO: NON VI RESTA CHE GODERVI APPIENO LA SEMPLICITÀ DI UN MOMENTO CONVIVIALE.

Espaces réduits, désir de simplicité et facilité d'utilisation: voilà les trois grands besoins, que la table Ares Book satisfait entièrement. Sa transformation est aussi facile comme d'ouvrir et de feuilleter un livre: il n'y a qu'à profiter de la simplicité d'être assis à table ensemble.

Small spaces available, aesthetic simplicity and user-friendliness: these are the three big requirements satisfied by Ares Book. Transforming this table is as easy as opening and leafing through a book: you just need to enjoy the simplicity of a friendly and happy moment.



05

**A R E S B O O K**  
design Altacom

Base/Piédement/Base: verniciato grafite gofrato M11  
Piano/Plateau/Top: nobilitato ardesia N24



# A R E S B O O K

ARES BOOK, IL NOME SUGGERISCE LA FUNZIONE E LA SUA VERSATILITÀ. IL PIANO SI APRE AGEVOLMENTE A LIBRO RESTITUENDO A QUESTO TAVOLINO UNA LETTURA INNOVATIVA, QUELLA CHE CONSENTE DI CAMBIARE POSIZIONE, DIMENSIONE E ALTEZZA SECONDO L'OCCORRENZA. ARES BOOK IL RACCONTO DELL'ESPERIENZA.

Ares Book, le nom suggère sa fonction et sa versatilité. Le plateau portefeuille s'ouvre facilement en donnant à cette table une interprétation innovante, qui permet de changer sa position, sa dimension et son hauteur au besoin. Ares Book, la narration de l'expérience.

Ares book, the name suggests its function and versatility. The top easily opens like a book giving to this table an innovative interpretation, the one that allows changing position, dimension and height at need. Ares book, the tale of experience.



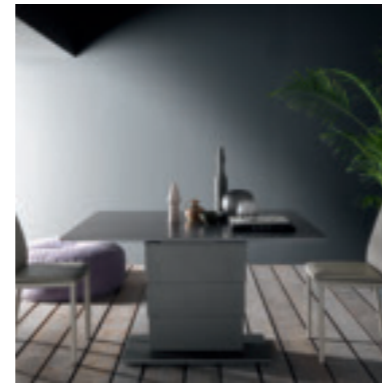
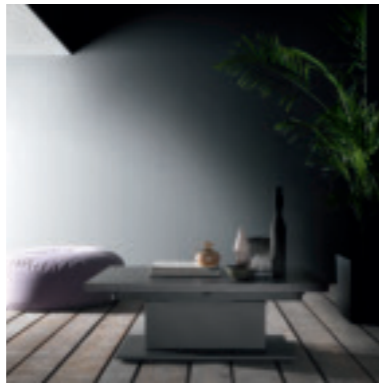

**FINITURE PIANO**  
**FINITIONS PLATEAU**  
**TOP FINISHES**

**NOBILITATO**  
**/ MÉLAMINE**  
**/ MELAMINE**

- N05 Bianco matrix
- N20 Natural halifax oak
- N21 Pino jackson
- N23 Cemento
- N24 Ardesia
- N25 Vintage chiaro
- N30 Morera
- N33 Resina silver
- N34 Resina grigio cenere
- N35 Rovere nodato caramel
- N36 Olmo moka

**LACCATO**  
**/ LAQUÉ**  
**/ LACQUERED**

Poro aperto  
/ Pores ouverts / Open pore

Opaco  
/ Mat / Matt

Lucido  
/ Brilliant / High gloss

- |     |     |     |                |
|-----|-----|-----|----------------|
| L31 | L51 | L01 | Bianco luce    |
| L32 | L52 |     | Bianco panna   |
| L33 | L53 |     | Bianco vela    |
| L34 | L54 |     | Grigio corda   |
| L35 | L55 |     | Grigio canapa  |
| L39 | L59 |     | Rosso aragosta |
| L40 | L60 |     | Tortora        |

**ROVERE IMPIALLACCIATO**  
**/ PLACAGE CHÊNE**  
**/ OAK VENEER**

- W01 Rovere naturale
- W02 Rovere grigio
- W03 Rovere tabacco
- W04 Rovere nodato
- W06 Rovere juta
- W07 Rovere fumé

**CERAMICA**  
**/ CÉRAMIQUE**  
**/ CERAMIC**

- K01 Fokos sale
- K02 Fokos terra
- K03 Fokos piombo

**LAMINAM**

**VETRO**  
**/ VERRE**  
**/ GLASS**

- G01 Bianco
- G02 Tortora
- G03 Nero
- G04 Bianco acidato
- G05 Tortora acidato
- G06 Nero acidato

**EFFETTO MALTA**  
**/ EFFET-BÉTON**  
**/ MORTAR-LOOK**

- E01 Corten black
- E02 Corten gold
- E03 Corten silver
- E04 Metalli vissuti nichel
- E05 Metalli vissuti rame
- E06 Beton tortora
- E07 Beton nero
- E08 Beton grigio scuro
- E09 Beton grigio chiaro
- E10 Pietra spatolata tortora
- E11 Pietra spatolata notte
- E12 Pietra spatolata cenere
- E13 Pietra spatolata perla
- E14 Pietra spatolata antracite
- E15 Pietra spatolata travertino
- E17 Pietra spatolata ardesia alluminio
- E19 Bianco assoluto

**Tavolino trasformabile in tavolo da pranzo, struttura centrale in acciaio, meccanismo a gas o elettrico a batteria ricaricabile, regolabile in altezza al millimetro da cm 39 a cm 79, piano raddoppiabile a libro nobilitato, laccato, legno, effetto malta, vetro o ceramica. Rotelle piroettanti a scomparsa. Brevettato.**

Table relevable en table de repas, piétement central en acier, haussement par vérin-gaz ou électrique à batterie rechargeable, réglable en hauteur au millimètre de cm 39 à cm 79, plateau doublant portefeuille mélamine, laqué, bois, effet-béton, verre ou céramique. Roulettes cachées sous-piètement. Breveté.

Transforming coffee table, it turns into a dining table, steel central column, gas or electric with rechargeable battery lifting device. Millimetre-adjustable height from cm 39 to cm 79, folded doubling top in melamine, glass, lacquered, stained wood, mortar-look or ceramic. Hidden under-plate castors. Patented.

**FINITURE BASE**  
**FINITIONS PIÉTEMENT**  
**BASE FINISHES**

**METALLO**  
**/ MÉTAUX**  
**/ METALS**

- M01 Inox
- M02 Verniciato grisou goffrato
- M03 Verniciato bianco opaco
- M04 Verniciato nero opaco
- M11 Verniciato grafite goffrato
- M12 Verniciato tortora opaco
- M19 Verniciato bronzo goffrato

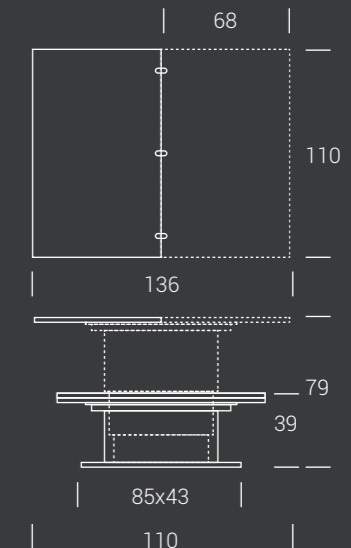



# HELIOS

HELIOS É UN TAVOLO DAL PIANO CIRCOLARE, ESTREMAMENTE VERSATILE NELLE FUNZIONI E NELL'ESTETICA. IL MECCANISMO É OPPORTUNAMENTE STUDIATO PER TRASFORMARSI DA SEDUCENTE TAVOLINO DA SALOTTO A TAVOLO DA PRANZO ALLUNGANDOSI CON ESTREMO COMFORT PER ABITANTI E OSPITI. LA STRUTTURA SOTTOSTANTE IN METALLO SI INCROCIA IN UN PIACEVOLE E SUGGESTIVO GIOCO DI LINEE.

Helios est une table avec un plateau rond, très versatile pour sa fonction et son esthétique. La mécanique est bien conçue pour une séduisante table basse qui se transforme en table de repas, qui s'allonge avec un confort extrême pour tous. La structure en métal en dessous se croise dans un intéressant jeu de lignes.

Helios, with its round top, is an extremely versatile table both in function and in design. The mechanism has been conveniently studied to transform from an alluring coffee table to a dining table, extending with ease for the family and guests. The metal base crossbreeds in a suggestive and pleasant linear visual effect.



06

**HELIOS**  
design Altacom

Base/Piédement/Base: verniciato bianco opaco M03  
Piano/Plateau/Top: ceramica bianco statuario venato lucido K05



HELIOS



# HELIOS



## FINITURE PIANO FINITIONS PLATEAU TOP FINISHES

### NOBILITATO / MÉLAMINE / MELAMINE

N05	Bianco matrix
N20	Natural halifax oak
N21	Pino jackson
N23	Cemento
N24	Ardesia
N25	Vintage chiaro
N30	Morera
N33	Resina silver
N34	Resina grigio cenere
N35	Rovere nodato caramel
N36	Olmo moka

### LACCATO / LAQUÉ / LACQUERED

Poro aperto  
/ Pores ouverts / Open pore

L31	Bianco luce
L32	Bianco panna
L33	Bianco vela
L34	Grigio corda
L35	Grigio canapa
L39	Rosso aragosta
L40	Tortora

### ROVERE IMPIALLACCIATO / PLACAGE CHÊNE / OAK VENEER

W01	Rovere naturale
W02	Rovere grigio
W03	Rovere tabacco
W04	Rovere nodato
W06	Rovere juta
W07	Rovere fumé

### CERAMICA / CÉRAMIQUE / CERAMIC

K01	Fokos sale
K02	Fokos terra
K03	Fokos piombo
K04	Noir desir lucido
K05	Bianco statuario venato lucido

**LAMINAM**

### EFFETTO MALTA / EFFET-BÉTON / MORTAR-LOOK

E01	Corten black
E02	Corten gold
E03	Corten silver
E04	Metalli vissuti nichel
E05	Metalli vissuti rame
E06	Beton tortora
E07	Beton nero
E08	Beton grigio scuro
E09	Beton grigio chiaro
E10	Pietra spatolata tortora
E11	Pietra spatolata notte
E12	Pietra spatolata cenere
E13	Pietra spatolata perla
E14	Pietra spatolata antracite
E15	Pietra spatolata travertino
E17	Pietra spatolata ardesia alluminio
E19	Bianco assoluto

### VETRO / VERRE / GLASS

G01	Bianco
G02	Tortora
G03	Nero
G04	Bianco acidato
G05	Tortora acidato
G06	Nero acidato

**Tavolino trasformabile in tavolo da pranzo, base in metallo, meccanismo a gas, regolabile in altezza al millimetro da cm 36 a cm 75, piano rotondo in nobilitato, legno, vetro, effetto malta e ceramica, prolunga interna a libro.**  
**Ruote a scomparsa.**

Table relevable en table de repas, piétement en métal, haussement par vérin-gaz, réglable en hauteur au millimètre de cm 36 à cm 75, plateau rond en mélamine, bois, verre, effet-béton et céramique, rallonge intégrée porte-feuille.  
Roulettes intégrées.

Transforming coffee table, it turns into a dining table. Metal frame, gas lifting device, millimetre-adjustable height from cm 36 to cm 75, melamine, stained wood, glass, mortar-look and ceramic round top, inside folded extension. Under-base wheels.

## FINITURE BASE FINITIONS PIÉTEMENT BASE FINISHES

### METALLO / MÉTAUX / METALS

M02	Verniciato grisou goffrato
M03	Verniciato bianco opaco
M04	Verniciato nero opaco
M05	Cromo lucido
M11	Verniciato grafite goffrato
M12	Verniciato tortora opaco
M19	Verniciato bronzo goffrato

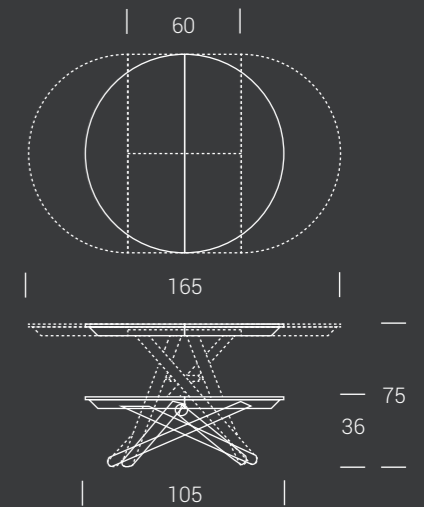

# LEVANTE

LEVANTE È UN TAVOLINO TRASFORMABILE CHE INTEGRA LA PARTICOLARITÀ DELLA STRUTTURA METALLICA AD INTRECCIO ALLA SOLIDITÀ DI UN PIANO AD ALTO SPESSORE PROPOSTA IN ROVERE MASSICCIO, UN CONCEPT CHE ABBRACCIA LA MODERNITÀ DELLA FUNZIONE SENZA RINUNCIARE A QUEL RICHIAMO ALLA NATURA COSÌ AMATA DAGLI ESTIMATORI DEL BELLO.

Levante est une table relevable qui combine la particularité de sa structure en métal et la solidité de son plateau épais en chêne vieux. Ce concept embrasse la modernité de la fonction, sans renoncer à l'appel de la nature, si chère à ceux qui aiment la beauté.

Levante is a transforming table that integrates the peculiarity of its bound metal structure with an old oak thick top. This concept embraces the modernity of the function without renouncing to a touch of much appreciated nature.



07

**LEVANTE**  
design Altacom

**Base/Piètement/Base:** verniciato grafite goffrato M11  
**Piano/Plateau/Top:** rovere vecchio massiccio termotrattato W21



LEVANTE



# LEVANTE



**Tavolino trasformabile in tavolo da pranzo, base in metallo, meccanismo a gas, regolabile in altezza al millimetro da cm 36 a cm 75, piano quadrato in nobilitato, legno, effetto malta e ceramica, due prolunghe interne. Ruote a scomparsa.**

Table relevable en table de repas, piétement en métal, haussement par vérin-gaz, réglable en hauteur au millimètre de cm 36 à cm 75, plateau carré en mélamine, bois, effet-béton et céramique, deux rallonges internes. Roulettes intégrées.

Transforming coffee table, it turns into a dining table. Metal frame, gas lifting device, millimetre-adjustable height from cm 36 to cm 75, melamine, stained wood, mortar-look and ceramic square top, two inside extensions. Under-base wheels.

## FINITURE PIANO FINITIONS PLATEAU TOP FINISHES

### NOBILITATO / MÉLAMINE / MELAMINE

- N05 Bianco matrix
- N20 Natural halifax oak
- N21 Pino jackson
- N23 Cemento
- N24 Ardesia
- N25 Vintage chiaro
- N30 Morera
- N33 Resina silver
- N34 Resina grigio cenere
- N35 Rovere nodato caramel
- N36 Olmo moka

### LACCATO / LAQUÉ / LACQUERED

Poro aperto  
/ Pores ouverts / Open pore

- L31 Bianco luce
- L32 Bianco panna
- L33 Bianco vela
- L34 Grigio corda
- L35 Grigio canapa
- L39 Rosso aragosta
- L40 Tortora

### EFFETTO MALTA / EFFET-BÉTON / MORTAR-LOOK

- E01 Corten black
- E02 Corten gold
- E03 Corten silver
- E04 Metalli vissuti nichel
- E05 Metalli vissuti rame
- E06 Beton tortora
- E07 Beton nero
- E08 Beton grigio scuro
- E09 Beton grigio chiaro
- E10 Pietra spatolata tortora
- E11 Pietra spatolata notte
- E12 Pietra spatolata cenere
- E13 Pietra spatolata perla
- E14 Pietra spatolata antracite
- E15 Pietra spatolata travertino
- E17 Pietra spatolata ardesia alluminio
- E19 Bianco assoluto

### ROVERE IMPIALLACCIATO / PLACAGE CHÊNE / OAK VENEER

- W01 Rovere naturale
- W02 Rovere grigio
- W03 Rovere tabacco
- W04 Rovere nodato
- W06 Rovere juta
- W07 Rovere fumé

### LEGNO MASSICCIO / BOISS MASSIF / SOLID WOOD

- W21 Rovere vecchio massiccio termotrattato
- W32 Rovere vecchio massiccio naturale
- W33 Rovere vecchio massiccio grigio
- W34 Larice fresato

## FINITURE BASE FINITIONS PIÉTEMENT BASE FINISHES

### METALLO / MÉTAUX / METALS

- M02 Verniciato grisou gofrato
- M03 Verniciato bianco opaco
- M04 Verniciato nero opaco
- M05 Cromo lucido
- M11 Verniciato grafite gofrato
- M12 Verniciato tortora opaco
- M19 Verniciato bronzo gofrato

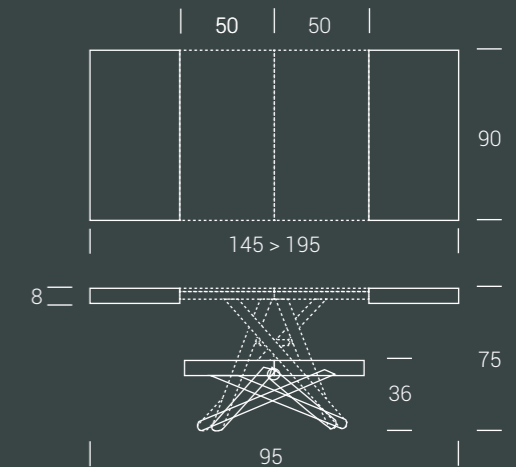



## TAVOLETTO

TAVOLETTO RAPPRESENTA L'ASPETTO PIÙ RIVOLUZIONARIO ED ECLETTICO DELL'INTERA GAMMA DI TRASFORMABILI ALTACOM. UN TAVOLINO, REALIZZATO IN ROVERE VECCHIO NATURALE, SI MUOVE IN ALTEZZA PER ASSOLVERE ALLA FUNZIONE DI TAVOLO DA PRANZO CHE ALL'OCCORRENZA SI EVOLVE DANDO FORMA AD UN COMODO LETTO DI RAFFINATO DESIGN. UN INVITO ALL'OSPITALITÀ E ALLA BELLEZZA DEL MADE IN ITALY.

Tavoletto représente le côté plus révolutionnaire et éclectique de toute la gamme gain-de-place altacom. Une table basse en vrai vieux chêne naturel, qui bouge en hauteur pour devenir une table de repas et qui au besoin évolue pour donner forme à un lit confortable, au design raffiné. Une invitation à l'hospitalité et au charme du made in italy.

Tavoletto represents the most revolutionary and eclectic aspect of the whole range of altacom space-saving. A couch table, made of real old natural oak, moves in height to assolve the dining table function, which evolves, if necessary, into a comfortable bed of refined design. An invitation to hospitality and to the charm of made in italy.



08

**TAVOLETTO**  
design Altacom

**Base/Piédement/Base:** cromo nero lucido M09  
**Piano/Plateau/Top:** rovere vecchio massiccio naturale W32

TAVOLETTO



TAVOLETTO

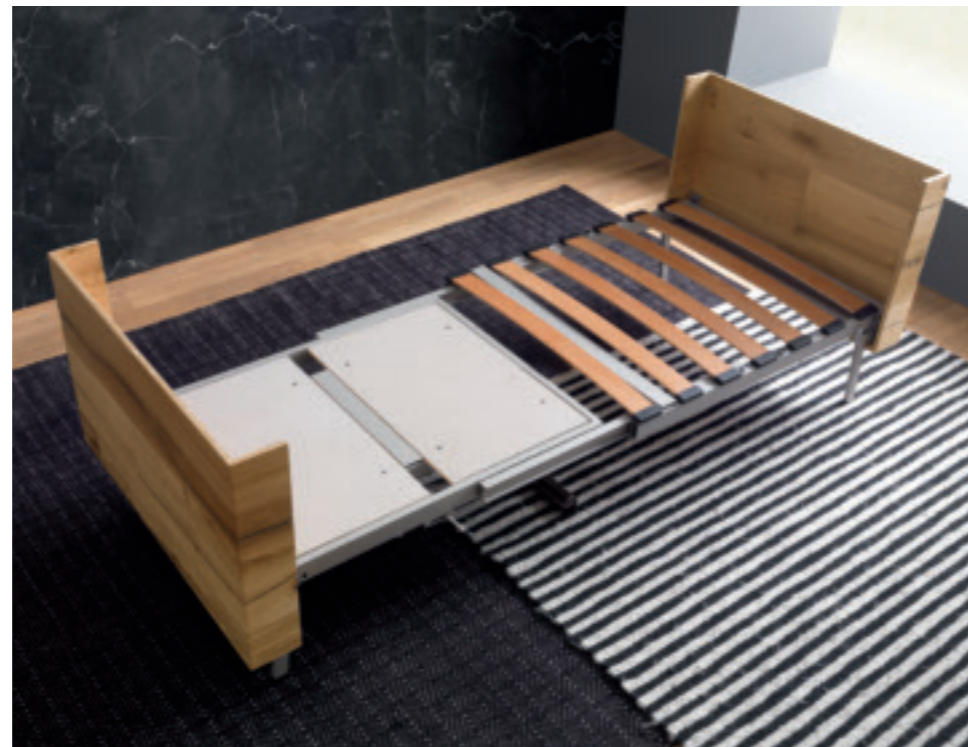



# TAVOLETTO

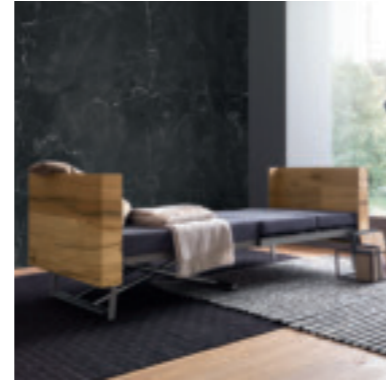
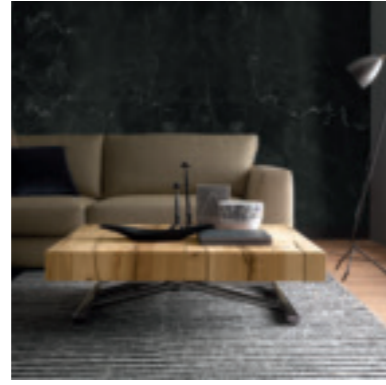

## FINITURE PIANO FINITIONS PLATEAU TOP FINISHES

### NOBILITATO / MÉLAMINE / MELAMINE

- N05 Bianco matrix
- N20 Natural halifax oak
- N21 Pino jackson
- N23 Cemento
- N24 Ardesia
- N25 Vintage chiaro
- N30 Morera
- N33 Resina silver
- N34 Resina grigio cenere
- N35 Rovere nodato caramel
- N36 Olmo moka

### LACCATO / LAQUÉ / LACQUERED

Poro aperto  
/ Pores ouverts / Open pore

- L31 Bianco luce
- L32 Bianco panna
- L33 Bianco vela
- L34 Grigio corda
- L35 Grigio canapa
- L39 Rosso aragosta
- L40 Tortora

### ROVERE IMPIALLACCIATO / PLACAGE CHÊNE / OAK VENEER

- W01 Rovere naturale
- W02 Rovere grigio
- W03 Rovere tabacco
- W04 Rovere nodato
- W06 Rovere juta
- W07 Rovere fumé

### LEGNO MASSICCIO / BOISS MASSIF / SOLID WOOD

- W21 Rovere vecchio massiccio termotrattato
- W32 Rovere vecchio massiccio naturale
- W33 Rovere vecchio massiccio grigio
- W34 Larice fresato

### EFFETTO MALTA / EFFET-BÉTON / MORTAR-LOOK

- E01 Corten black
- E02 Corten gold
- E03 Corten silver
- E04 Metalli vissuti nichel
- E05 Metalli vissuti rame
- E06 Beton tortora
- E07 Beton nero
- E08 Beton grigio scuro
- E09 Beton grigio chiaro
- E10 Pietra spatolata tortora
- E11 Pietra spatolata notte
- E12 Pietra spatolata cenere
- E13 Pietra spatolata perla
- E14 Pietra spatolata antracite
- E15 Pietra spatolata travertino
- E17 Pietra spatolata ardesia alluminio
- E19 Bianco assoluto

**Tavolino trasformabile in tavolo da pranzo oppure in letto, base in metallo, meccanismo a gas, regolabile in altezza al millimetro da cm 25 a cm 75, piano rettangolare in nobilitato, legno o effetto malta. Ruote a scomparsa. Dotato di pouff trasformabile in materasso (schiuma poliuretano ignifugo D 35), rivestito in tessuto beige o grigio. Rete a doghe e pannello in legno multistrato. Gambe pieghevoli di supporto.**

Table relevable transformable en table de repas ou en lit, piètement en métal,haussement par vérin gaz, réglable en hauteur au millimètre de cm 25 à cm 75, plateau mélamine, bois ou effet-béton. Roulettes intégrées. Avec pouff transformable en matelas (mousse polyuréthane ignifuge D35), revêtu en tissu beige ou gris. Sommier à lattes et panneau en contreplaqué. Pieds pliables à support.

Transforming coffee table, it turns into a dining table or into a bed, metal frame, gas lifting device, millimeter-adjustable height from cm 25 to cm 75, melamine, wood or mortal-look rectangular top. Under-base wheels. Including beige or grey fabric covered pouff, converting to mattress (fire retardant polyurethane foam D35). Bedspring with multilayer slats and panel. Supporting folding legs.

## FINITURE BASE FINITIONS PIÉTEMENT BASE FINISHES

### METALLO / MÉTAUX / METALS

- M02 Verniciato. grisou gofrato
- M03 Verniciato bianco opaco
- M04 Verniciato. nero opaco
- M05 Cromo lucido
- M07 Cromo opaco
- M09 Cromo nero lucido
- M10 Cromo nero opaco
- M11 Verniciato grafite gofrato
- M12 Verniciato tortora opaco
- M15 Oro lucido
- M19 Verniciato bronzo gofrato

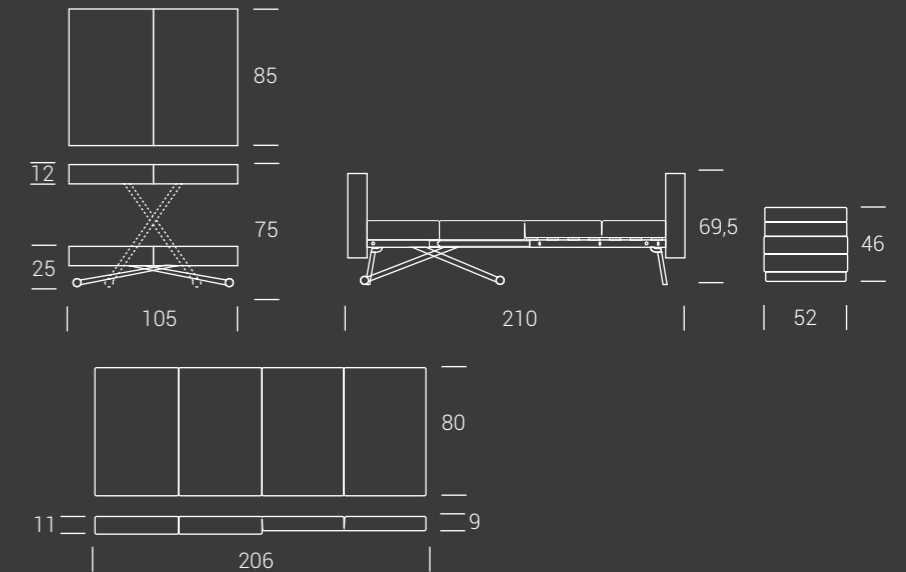

## FINITURE POUF/MATERASSO POUF/MATELAS FINITIONS POUF/MATTRESS FINISHES

### MATERASSO / MATELAS / MATTRESS

- B01 Grigio
- B02 Beige

# ICARO

NESSUN VOLO PINDARICO, MA UNA PRATICITÀ INGEGNOSA QUELLA PROPOSTA DA ICARO, IL TAVOLO TRASFORMABILE CHE SI PIEGA COME UN ORIGAMI PER LIBERARE O ARREDARE LO SPAZIO SECONDO LE ESIGENZE DEL CASO. UN VERO REGALO PER CHI AMA SOLUZIONI DINAMICHE E CREATIVE NEL PROPRIO SPAZIO ABITATIVO.

Icaro n'implique pas un effort d'imagination, mais une intelligente commodité. Une table relevable qui se plie comme un origami pour meubler ou faire de la place selon ses besoins. Un vrai cadeau pour ceux qui aiment des solutions dynamiques et créatives.

Icaro will bring your expectations beyond imagination with its smart practicality. This table folds like an origami to free or decorate space following any need. A real gift for those who love dynamic and creative solutions in its house.



09

**ICARO**  
Design Nils Frederking

Base/Piètement/Base: verniciato bronzo goffrato M19  
Piano/Plateau/Top: nobilitato natural halifax oak N20





ICARO





# I C A R O

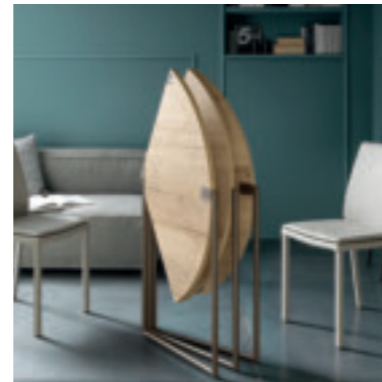

**Tavolo pieghevole con apertura a compasso, base in metallo e piano pieghevole in nobilitato. Profondità minima di 8 cm da chiuso, piano tondo diametro 120 cm quando aperto.**

Table pliante avec ouverture pivotante, piétement en métal et plateau pliant en mélamine. Profondeur minimale de 8 cm en position fermée, plateau rond diamètre 120 cm en position ouverte.

Folding table with pivotable structure, metal frame and melamine folding top. Minimum depth of 8 cm once closed, round top diameter 120 cm once open.

## FINITURE PIANO FINITIONS PLATEAU TOP FINISHES

### NOBILITATO / MÉLAMINE / MELAMINE

N05	Bianco matrix
N20	Natural halifax oak
N21	Pino jackson
N23	Cemento
N24	Ardesia
N25	Vintage chiaro
N30	Morera
N33	Resina silver
N34	Resina grigio cenere
N35	Rovere nodato caramel
N36	Olmo moka

## FINITURE BASE FINITIONS PIÉTEMENT BASE FINISHES

### METALLO / MÉTAUX / METALS

M02	Verniciato grisou goffrato
M03	Verniciato bianco opaco
M04	Verniciato nero opaco
M11	Verniciato grafite goffrato
M12	Verniciato tortora opaco
M19	Verniciato bronzo goffrato

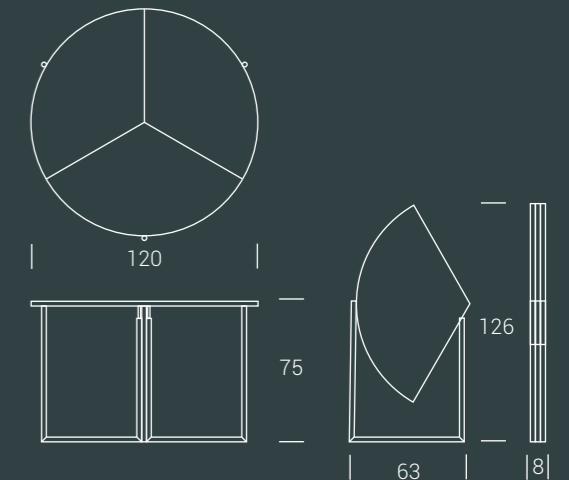

# ULISSE

UN TAVOLINO DALLE LINEE "MINIMAL" CON MECCANISMO A GAS, SI TRASFORMA ALL'OCCORRENZA IN UN TAVOLO DA PRANZO CON SEMPLICI MOVIMENTI DELLA MANO. RAFFINATA LA FINITURA EFFETTO MALTA DEL PIANO AD ALTO SPESSORE.

Une table aux lignes « minimales » avec assésment par vérin gaz, se transforme si besoin dans une table de repas avec des gestes simples. Très raffinée la finition effet-béton du plateau de forte épaisseur.

A table with "minimal" lines and a gas lifting mechanism, it turns, if necessary, into a dining table with a few simple movements. Definitely refined the mortar-look finishing of the high thickness top.



10  
**ULISSE**  
design Altacom

Base/Piédement/Base: verniciato grafite gofrato M11  
Piano/Plateau/Top: effetto malta beton grigio scuro E08



U L I S S E

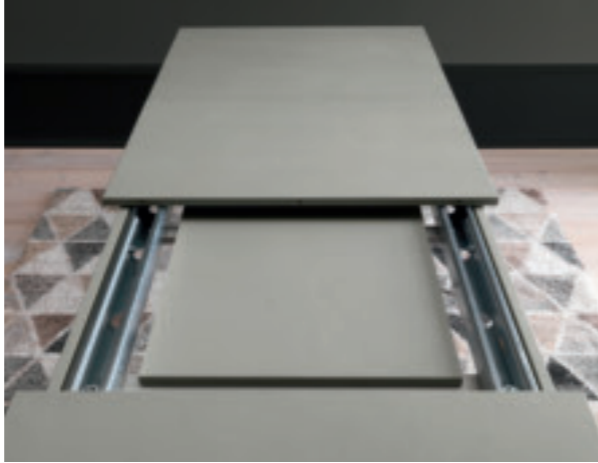



LE STRAORDINARIE PRESTAZIONI SONO IL RISULTATO DI UN MECCANISMO INTERNO ESTREMAMENTE EFFICACE CHE NON SI LASCIA PERCEPIRE ALLA VISTA IN QUALSIASI POSIZIONE DI ALLUNGA. UNIONI PERFETTAMENTE COINCIDENTI UNITE AD UN'ESTETICA RAFFINATA FANNO DI ULISSE UN MITO CONTEMPORANEO.

Des performances extraordinaires sont le résultat d'un mécanisme "caché" extrêmement efficace qui ne se laisse pas apercevoir en toute position. Des jonctions parfaitement coïncidentes, combinées avec une esthétique raffinée, transforment ulisse en un mythe contemporain.

Extraordinary performances are the result of an extremely efficient hidden mechanism that is not perceived at any position. Perfectly coincident junctions along with a refined beauty distinguish ulisse as contemporary myth.

U L I S S E



10  
ULISSE  
design Altacom

# U L I S S E



## FINITURE PIANO FINITIONS PLATEAU TOP FINISHES

### NOBILITATO / MÉLAMINE / MELAMINE

N05	Bianco matrix
N20	Natural halifax oak
N21	Pino jackson
N23	Cemento
N24	Ardesia
N25	Vintage chiaro
N30	Morera
N33	Resina silver
N34	Resina grigio cenere
N35	Rovere nodato caramel
N36	Olmo moka

### LACCATO / LAQUÉ / LACQUERED

### ROVERE IMPIALLACCIATO / PLACAGE CHÊNE / OAK VENEER

W01	Rovere naturale
W02	Rovere grigio
W03	Rovere tabacco
W04	Rovere nodato
W06	Rovere juta
W07	Rovere fumé

### CERAMICA / CÉRAMIQUE / CERAMIC

K01	Fokos sale
K02	Fokos terra
K03	Fokos piombo
K04	Noir desir lucido
K05	Bianco statuario venato lucido

### LEGNO MASSICCIO / BOISS MASSIF / SOLID WOOD

W21	Rovere vecchio massiccio termotrattato
W32	Rovere vecchio massiccio naturale
W33	Rovere vecchio massiccio grigio
W34	Larice fresato

### Poro aperto / Pores ouverts / Open pore

### Opaco / Mat / Matt

### Lucido / Brilliant / High gloss

L31	L51	L01	Bianco luce
L32	L52		Bianco panna
L33	L53		Bianco vela
L34	L54		Grigio corda
L35	L55		Grigio canapa
L39	L59		Rosso aragosta
L40	L60		Tortora

### EFFETTO MALTA / EFFET-BÉTON / MORTAR-LOOK

E01	Corten black
E02	Corten gold
E03	Corten silver
E04	Metalli vissuti nichel
E05	Metalli vissuti rame
E06	Beton tortora
E07	Beton nero
E08	Beton grigio scuro
E09	Beton grigio chiaro
E10	Pietra spatolata tortora
E11	Pietra spatolata notte
E12	Pietra spatolata cenere
E13	Pietra spatolata perla
E14	Pietra spatolata antracite
E15	Pietra spatolata travertino
E17	Pietra spatolata ardesia alluminio
E19	Bianco assoluto

**Tavolino trasformabile in tavolo da pranzo, base in metallo, meccanismo a gas, regolabile in altezza al millimetro da cm 28 a cm 88, piano rettangolare in nobilitato, laccato, legno, effetto malta o ceramica, 2 prolunghe interne. Ruote a scomparsa.**

Table relevable en table de repas, piétement en acier, haussement par vérin-gaz, réglable en hauteur au millimètre de cm 28 à cm 88, plateau rectangulaire en mélamine, laqué, bois, effet-béton ou céramique, 2 rallonges internes. Roulettes intégrées.

Transforming coffee table, it turns into a dining table. Metal frame, gas lifting device, millimetre-adjustable height from cm 28 to cm 88, melamine, lacquered, wood, mortar-look or ceramic rectangular top, 2 inside extensions. Under-base wheels.

## FINITURE BASE FINITIONS PIÉTEMENT BASE FINISHES

### METALLO / MÉTAUX / METALS

M02	Verniciato grisou goffrato
M03	Verniciato bianco opaco
M04	Verniciato nero opaco
M05	Cromo lucido
M07	Cromo opaco
M09	Cromo nero lucido
M10	Cromo nero opaco
M11	Verniciato grafite goffrato
M12	Verniciato tortora opaco
M15	Oro lucido
M19	Verniciato bronzo goffrato

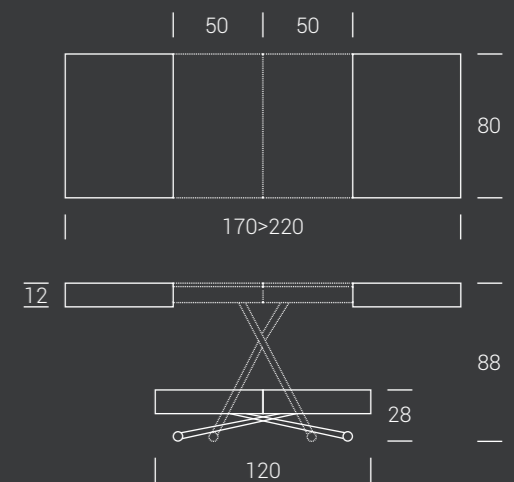

# COMPACT



ESSERE "ALL'ALTEZZA" É UNA DELLE PREROGATIVE DEL TRASFORMABILE COMPACT, UN TAVOLINO COSÌ VERSATILE DA DIVENIRE UN AUTENTICO PASSE-PARTOUT DEL LIVING CONTEMPORANEO, UN'ESTETICA ECLETTICA PER FUNZIONE, ESTREMAMENTE TATTILE NELLE SUPERFICI DEL PIANO IN LARICE FRESATO.

Être "à la hauteur" est une des caractéristiques de compact, une table relevable tellement versatile de devenir un authentique passe-partout de l'habitat contemporain, une esthétique éclectique par fonction, extrêmement tactile sur la surface du plateau en mélèze fraisé.

"Measuring up" is one of the peculiarities of compact, a so versatile transforming table to become an authentic passe-partout of the contemporary living, an eclectic design in function, extremely tactile in the surface of the milled larch top.



11

**COMPACT**  
design Altacom

Base/Piédement/Base: cromo nero lucido M09  
Piano/Plateau/Top: larice fresato W34



# COMPACT



IL SISTEMA DI PROLUNGHE INTERNE A LIBRO CONSENTE DI AMPLIARE IL PIANO D'APPOGGIO SECONDO LE ESIGENZE FUNZIONALI E LO SPAZIO DISPONIBILE. COMPACT, IDEE IN MOVIMENTO.

Le système de rallonges internes à portefeuille permet d'étendre le plateau selon les besoins fonctionnels et l'espace disponible. Compact, des idées en mouvement.

The integrated folding extensions' system enables the top surface to extend following the functional requirements and the space available. Compact, moving ideas.



## COMPACT



## FINITURE PIANO FINITIONS PLATEAU TOP FINISHES

### NOBILITATO / MÉLAMINE / MELAMINE

- N05 Bianco matrix
- N20 Natural halifax oak
- N21 Pino jackson
- N23 Cemento
- N24 Ardesia
- N25 Vintage chiaro
- N30 Morera
- N33 Resina silver
- N34 Resina grigio cenere
- N35 Rovere nodato caramel
- N36 Olmo moka

### LACCATO / LAQUÉ / LACQUERED

### ROVERE IMPIALLACCIATO / PLACAGE CHÊNE / OAK VENEER

- W01 Rovere naturale
- W02 Rovere grigio
- W03 Rovere tabacco
- W04 Rovere nodato
- W06 Rovere juta
- W07 Rovere fumé

### LEGNO MASSICCIO / BOISS MASSIF / SOLID WOOD

- W21 Rovere vecchio massiccio termotrattato
- W32 Rovere vecchio massiccio naturale
- W33 Rovere vecchio massiccio grigio
- W34 Larice fresato

Poro aperto  
/ Pores ouverts / Open pore

- L31 Bianco luce
- L32 Bianco panna
- L33 Bianco vela
- L34 Grigio corda
- L35 Grigio canapa
- L39 Rosso aragosta
- L40 Tortora

### EFFETTO MALTA / EFFET-BÉTON / MORTAR-LOOK

- E01 Corten black
- E02 Corten gold
- E03 Corten silver
- E04 Metalli vissuti nichel
- E05 Metalli vissuti rame
- E06 Beton tortora
- E07 Beton nero
- E08 Beton grigio scuro
- E09 Beton grigio chiaro
- E10 Pietra spatolata tortora
- E11 Pietra spatolata notte
- E12 Pietra spatolata cenere
- E13 Pietra spatolata perla
- E14 Pietra spatolata antracite
- E15 Pietra spatolata travertino
- E17 Pietra spatolata ardesia alluminio
- E19 Bianco assoluto

**Tavolino trasformabile in tavolo da pranzo, base in metallo, meccanismo a gas, regolabile in altezza al millimetro da cm 25 a cm 84, piano rettangolare in nobilitato, legno o effetto malta, con 2 prolunghe interne a libro. Ruote a scomparsa.**

Table relevable en table de repas, piétement en métal, haussement par vérin-gaz, réglable en hauteur au millimètre de cm 25 à cm 84, plateau rectangulaire en mélamine, bois ou effet-béton, 2 rallonges intégrées à portefeuille. Roulettes intégrées.

Transforming coffee table, it turns into a dining table. Metal frame, gas lifting device, millimetre-adjustable height from cm 25 to cm 84, melamine, stained wood or mortar-look top, 2 inside folded extensions. Under-base wheels.

## FINITURE BASE FINITIONS PIÉTEMENT BASE FINISHES

### METALLO / MÉTAUX / METALS

- M02 Verniciato grisou goffrato
- M03 Verniciato bianco opaco
- M04 Verniciato nero opaco
- M05 Cromo lucido
- M07 Cromo opaco
- M09 Cromo nero lucido
- M10 Cromo nero opaco
- M11 Verniciato grafite goffrato
- M12 Verniciato tortora opaco
- M15 Oro lucido
- M19 Verniciato bronzo goffrato

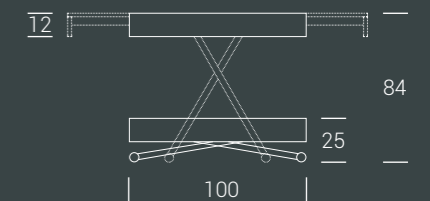
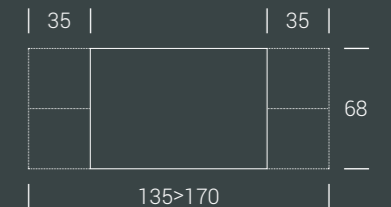

# ASSIST

UN TAVOLINO DA SOGGIORNO DALLE PRESTAZIONI STRAORDINARIE, CHE SI TRASFORMA IN UN TAVOLO DA PRANZO CHE PERMETTE DI OSPITARE COMODAMENTE FINO A 14 PERSONE. ASSIST È STATO REALIZZATO PER SODDISFARE LA VOGLIA DI PERSONALIZZARE AL MASSIMO GLI SPAZI DI CASA GIOCANDO CON L'ARREDAMENTO, DIVERTENDOSI.

Des performances extraordinaires pour cette table relevable en table de repas, dont l'extension permet d'accueillir à table jusqu'à 14 personnes en tout confort. Assist permet de personnaliser au maximum les espaces de la maison, en jouant avec le décor, en s'amusant.

A coffee table with extraordinary performance, that turns into a dining table which can host up to 14 people. Assist has been conceived to satisfy the need of fully personalizing the home space by playing with furniture and having fun.











**FINITURE PIANO**  
**FINITIONS PLATEAU**  
**TOP FINISHES**

**NOBILITATO**  
**/ MÉLAMINE**  
**/ MELAMINE**

- N05 Bianco matrix
- N20 Natural halifax oak
- N21 Pino jackson
- N23 Cemento
- N24 Ardesia
- N25 Vintage chiaro
- N30 Morera
- N33 Resina silver
- N34 Resina grigio cenere
- N35 Rovere nodato caramel
- N36 Olmo moka

**LACCATO**  
**/ LAQUÉ**  
**/ LACQUERED**

Poroso aperto / Pores ouverts / Open pore	Opaco / Mat / Matt	Lucido / Brilliant / High gloss	
L31	L51	L01	Bianco luce
L32	L52		Bianco panna
L33	L53		Bianco vela
L34	L54		Grigio corda
L35	L55		Grigio canapa
L39	L59		Rosso aragosta
L40	L60		Tortora

**ROVERE IMPIALLACCIATO**  
**/ PLACAGE CHÊNE**  
**/ OAK VENEER**

- W01 Rovere naturale
- W02 Rovere grigio
- W03 Rovere tabacco
- W04 Rovere nodato
- W06 Rovere juta
- W07 Rovere fumé

**LEGNO MASSICCIO**  
**/ BOISS MASSIF**  
**/ SOLID WOOD**

- W21 Rovere vecchio massiccio termotrattato
- W32 Rovere vecchio massiccio naturale
- W33 Rovere vecchio massiccio grigio
- W34 Larice fresato

**CERAMICA**  
**/ CÉRAMIQUE**  
**/ CERAMIC**

- K01 Fokos sale
- K02 Fokos terra
- K03 Fokos piombo
- K04 Noir desir lucido
- K05 Bianco statuario venato lucido

**EFFETTO MALTA**  
**/ EFFET-BÉTON**  
**/ MORTAR-LOOK**

- E01 Corten black
- E02 Corten gold
- E03 Corten silver
- E04 Metalli vissuti nichel
- E05 Metalli vissuti rame
- E06 Beton tortora
- E07 Beton nero
- E08 Beton grigio scuro
- E09 Beton grigio chiaro
- E10 Pietra spatolata tortora
- E11 Pietra spatolata notte
- E12 Pietra spatolata cenere
- E13 Pietra spatolata perla
- E14 Pietra spatolata antracite
- E15 Pietra spatolata travertino
- E17 Pietra spatolata ardesia alluminio
- E19 Bianco assoluto

**Tavolino trasformabile in tavolo da pranzo, base in metallo, meccanismo a gas, regolabile in altezza al millimetro da cm 25 a cm 76, piano rettangolare in nobilitato, laccato, legno, effetto malta o ceramica, 2 prolunghe interne e 2 prolunghe esterne. Ruote a scomparsa. Gambe pieghevoli di supporto.**

Table relevable en table de repas, piètement central en métal,haussement par vérin-gaz, réglable en hauteur au millimètre de cm 25 à cm 76, plateau rectangulaire en mélamine,laqué, bois, effet-béton ou céramique,2 rallonges internes et 2 rallonges externes. Roulettes intégrées. Pieds pliables à support des rallonges.

Transforming coffee table, it turns into a dining table. Metal frame, gas lifting device, millimetre-adjustable height from cm 25 to cm 76, melamine, lacquered, stained wood, mortar-look or ceramic rectangular top, 2 inside extensions and 2 external extensions. Under-base wheels. Supporting folding legs.

**FINITURE BASE**  
**FINITIONS PIÉTEMENT**  
**BASE FINISHES**

**METALLO**  
**/ MÉTAUX**  
**/ METALS**

- M02 Verniciato griso goffrato
- M03 Verniciato bianco opaco
- M04 Verniciato nero opaco
- M05 Cromo lucido
- M07 Cromo opaco
- M09 Cromo nero lucido
- M10 Cromo nero opaco
- M11 Verniciato grafite goffrato
- M12 Verniciato tortora opaco
- M15 Oro lucido
- M19 Verniciato bronzo goffrato

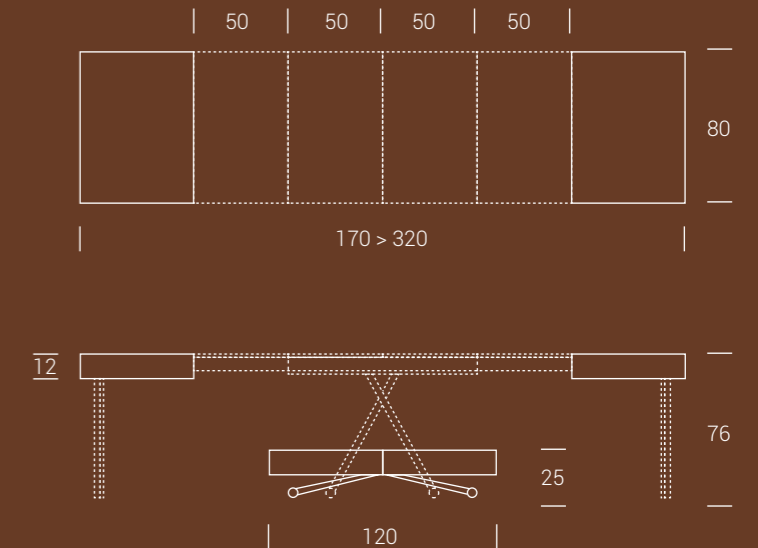



# DOUBLE

DOUBLE È IL TAVOLINO TRASFORMABILE CHE SODDISFA DUE RICHIESTE: È IDEALE PER CHI NON AMA IL TAVOLO CON UN'EVIDENTE DIVISIONE A METÀ MA NON VUOLE COMUNQUE RINUNCIARE AL PIANO CASSONATO.

Double est une table relevable qui satisfait deux demandes différentes: la table idéale pour ceux qui n'aiment pas trop le plateau coupé au milieu, sans renoncer au plateau de forte épaisseur.

Double is a transforming table that satisfies two needs: it's perfect for people who don't like to see the top divided in half while maintaining its folded top.



DOUBLE



13  
DOUBLE  
design Altacom

## DOUBLE



### FINITURE PIANO FINITIONS PLATEAU TOP FINISHES

#### NOBILITATO / MÉLAMINE / MELAMINE

- N05 Bianco matrix
- N20 Natural halifax oak
- N21 Pino jackson
- N23 Cemento
- N24 Ardesia
- N25 Vintage chiaro
- N30 Morera
- N33 Resina silver
- N34 Resina grigio cenere
- N35 Rovere nodato caramel
- N36 Olmo moka

#### LACCATO / LAQUÉ / LACQUERED

Poros aperto  
/ Pores ouverts / Open pore

- L31 Bianco luce
- L32 Bianco panna
- L33 Bianco vela
- L34 Grigio corda
- L35 Grigio canapa
- L39 Rosso aragosta
- L40 Tortora

#### ROVERE IMPIALLACCIATO / PLACAGE CHÊNE / OAK VENEER

- W01 Rovere naturale
- W02 Rovere grigio
- W03 Rovere tabacco
- W04 Rovere nodato
- W06 Rovere juta
- W07 Rovere fumé

#### LEGNO MASSICCIO / BOISS MASSIF / SOLID WOOD

- W21 Rovere vecchio massiccio termotrattato
- W32 Rovere vecchio massiccio naturale
- W33 Rovere vecchio massiccio grigio
- W34 Larice fresato

#### EFFETTO MALTA / EFFET-BÉTON / MORTAR-LOOK

- E01 Corten black
- E02 Corten gold
- E03 Corten silver
- E04 Metalli vissuti nichel
- E05 Metalli vissuti rame
- E06 Beton tortora
- E07 Beton nero
- E08 Beton grigio scuro
- E09 Beton grigio chiaro
- E10 Pietra spatolata tortora
- E11 Pietra spatolata notte
- E12 Pietra spatolata cenere
- E13 Pietra spatolata perla
- E14 Pietra spatolata antracite
- E15 Pietra spatolata travertino
- E17 Pietra spatolata ardesia alluminio
- E19 Bianco assoluto

**Tavolino trasformabile in tavolo da pranzo, base in metallo, meccanismo a gas, regolabile in altezza al millimetro da cm 29 a cm 87, piano rettangolare in nobilitato, laccato, legno o effetto malta, con 2 prolunghe interne a libro. Ruote a scomparsa.**

Table relevable en table de repas, piétement en métal, haussement par vérin-gaz, réglable en hauteur au millimètre de cm 29 à cm 87, plateau rectangulaire en mélamine, laqué, bois ou effet-béton, 2 rallonges intégrées à portefeuille. Roulettes intégrées.

Transforming coffee table, it turns into a dining table. Metal frame, gas lifting device, millimetre-adjustable height from cm 29 to cm 87, melamine, lacquered, stained wood or mortar-look top, 2 inside folded extensions. Under-base wheels.

### FINITURE BASE FINITIONS PIÉTEMENT BASE FINISHES

#### METALLO / MÉTAUX / METALS

- M02 Verniciato grisou goffrato
- M03 Verniciato bianco opaco
- M04 Verniciato nero opaco
- M05 Cromo lucido
- M07 Cromo opaco
- M09 Cromo nero lucido
- M10 Cromo nero opaco
- M11 Verniciato grafite goffrato
- M12 Verniciato tortora opaco
- M15 Oro lucido
- M19 Verniciato bronzo goffrato

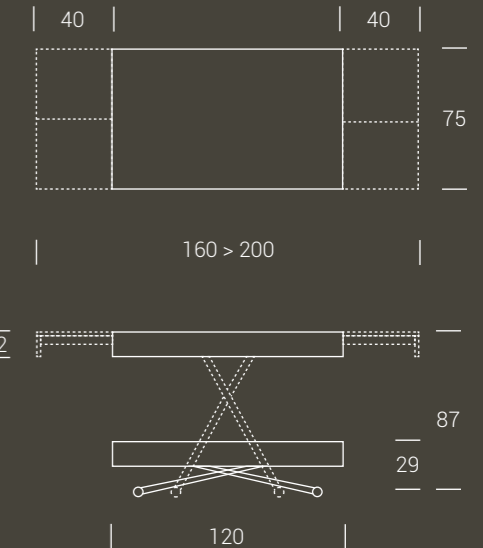

# GINGILLO

GINGILLO È UNA VERA CHICCA. UN TAVOLINO DI DIMENSIONI DISCRETE, UN DESIGN SEMPLICE E LA FACILITÀ DI UTILIZZO CHE NON DELUDE: IN SOLE DUE MOSSE RADDOPPIA LA SUA LUNGHEZZA. L'ESSENZIALITÀ DI GINGILLO È CIÒ CHE CI VUOLE QUANDO NATURALITÀ E GENUINITÀ SONO I VALORI IN CUI CREDIAMO E CHE DESIDERIAMO ESPRIMERE ATTRAVERSO L'ARREDAMENTO CHE SCEGLIAMO.

Gingillo est vraiment exceptionnelle. Une table aux dimensions limitées, un design simple, la praticité de la fonction: avec seulement deux gestes le plateau se double en longueur. L'essentialité de Gingillo est le bon choix, si on recherche la naturalité et l'authenticité dans le décor choisi.

Gingillo is a real gem. A table with moderate dimensions, simple design and easy of use: it doubles its length in only two moves. With its concision we want to express the values of naturalness and genuineness in which we believe and that we express through our choice of furniture.







# GINGILLO

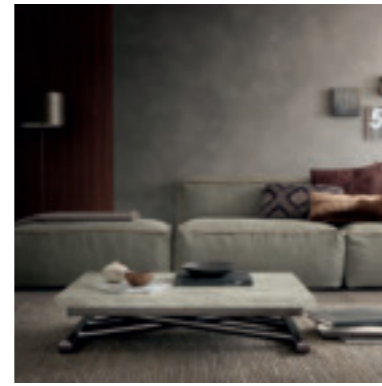

## FINITURE PIANO FINITIONS PLATEAU TOP FINISHES

### NOBILITATO / MÉLAMINE / MELAMINE

- N05 Bianco matrix
- N20 Natural halifax oak
- N21 Pino jackson
- N23 Cemento
- N24 Ardesia
- N25 Vintage chiaro
- N30 Morera
- N33 Resina silver
- N34 Resina grigio cenere
- N35 Rovere nodato caramel
- N36 Olmo moka

### LACCATO / LAQUÉ / LACQUERED

Poro aperto  
/ Pores ouverts / Open pore

- L31 Bianco luce
- L32 Bianco panna
- L33 Bianco vela
- L34 Grigio corda
- L35 Grigio canapa
- L39 Rosso aragosta
- L40 Tortora

### ROVERE IMPIALLACCIATO / PLACAGE CHÊNE / OAK VENEER

- W01 Rovere naturale
- W02 Rovere grigio
- W03 Rovere tabacco
- W04 Rovere nodato
- W06 Rovere juta
- W07 Rovere fumé

### CERAMICA / CÉRAMIQUE / CERAMIC

- K01 Fokos sale
- K02 Fokos terra
- K03 Fokos piombo

**LAMINAM**

### EFFETTO MALTA / EFFET-BÉTON / MORTAR-LOOK

- E01 Corten black
- E02 Corten gold
- E03 Corten silver
- E04 Metalli vissuti nichel
- E05 Metalli vissuti rame
- E06 Beton tortora
- E07 Beton nero
- E08 Beton grigio scuro
- E09 Beton grigio chiaro
- E10 Pietra spatolata tortora
- E11 Pietra spatolata notte
- E12 Pietra spatolata cenere
- E13 Pietra spatolata perla
- E14 Pietra spatolata antracite
- E15 Pietra spatolata travertino
- E17 Pietra spatolata ardesia alluminio
- E19 Bianco assoluto

### VETRO / VERRE / GLASS

- G01 Bianco
- G02 Tortora
- G03 Nero
- G04 Bianco acidato
- G05 Tortora acidato
- G06 Nero acidato

**Tavolino trasformabile in tavolo da pranzo, base in metallo, meccanismo a gas, regolabile in altezza al millimetro da cm 25 a cm 78, piano a libro raddoppiabile in lunghezza in nobilitato, legno, effetto malta, vetro o ceramica. Ruote a scomparsa.**

Table relevable en table de repas, piétement en métal, haussement par vérin-gaz, réglable en hauteur au millimètre de cm 25 à cm 78, plateau portefeuille doublant en longueur en mélamine, bois, effet-béton, verre ou céramique. Roulettes intégrées.

Transforming coffee table, it turns into a dining table, metal frame, gas lifting device, millimetre-adjustable height from cm 25 to cm 78, melamine, glass, stained wood, mortar-look or ceramic doubling in length top. Under base wheels.

## FINITURE BASE FINITIONS PIÉTEMENT BASE FINISHES

### METALLO / MÉTAUX / METALS

- M02 Verniciato grisou gofrato
- M03 Verniciato bianco opaco
- M04 Verniciato nero opaco
- M05 Cromo lucido
- M07 Cromo opaco
- M09 Cromo nero lucido
- M10 Cromo nero opaco
- M11 Verniciato grafite gofrato
- M12 Verniciato tortora opaco
- M15 Oro lucido
- M19 Verniciato bronzo gofrato

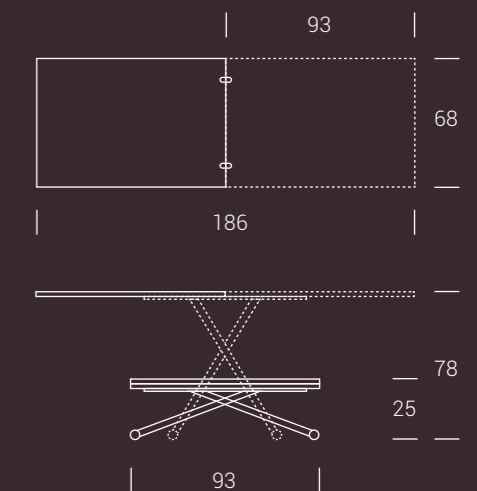

# BESSY

SE VI CAPITA SPESSO DI PENSARE CHE AVRESTE PROPRIO BISOGNO DELLO SPAZIO LIBERO OCCUPATO DAL VOSTRO TAVOLINO DA SOGGIORNO, BESSY È CIÒ CHE FA PER VOI. LA FUNZIONE CHE LO RENDE DAVVERO SPECIALE È LA POSSIBILITÀ DI ABBASSARLO FINO A 16 CM, COSÌ DA FARLO SCOMPARIRE FACILMENTE SOTTO LETTI E DIVANI, PER VIVERE AL MASSIMO OGNI CENTIMETRO A DISPOSIZIONE.

Si vous avez besoin de tout l'espace disponible de votre maison, même la place de votre table basse, Bessy est la solution qu'il vous faut, grâce à sa fonction extraordinairement unique: elle se baisse à 16 cm, ce qui permet de la ranger facilement sous un canapé ou un lit. Parfaite pour ceux qui veulent exploiter au maximum chaque centimètre de la maison.

If you often think that you would really need the space occupied by your coffee table, Bessy is the right solution for you. The function that makes it so special is the possibility of reducing its height to cm 16, so that you can easily make it disappear under a bed or a couch. It is the perfect solution for those who want to live every centimeter available in the house.





B E S S Y



# BESSY



**Tavolino trasformabile in tavolo da pranzo, base in metallo, meccanismo a gas, regolabile in altezza al millimetro da cm 16 a cm 78, piano raddoppiabile a libro in nobilitato, laccato, legno, effetto malta, vetro o ceramica. Ruote a scomparsa e rotelle trasversali.**

Table relevable en table de repas, piétement en métal, haussement par vérin-gaz, réglable en hauteur au millimètre de cm 16 à cm 78, plateau portefeuille en mélamine, laqué, bois, effet-béton, verre ou céramique. Roulettes intégrées et roulettes transversales.

Transforming coffee table which turns into a dining table. Metal frame, gas lifting device, millimetre-adjustable height from cm 16 to cm 78, melamine, glass, lacquered, stained wood, mortar-look or ceramic doubling top. Under-base wheels and side translation castors.

## FINITURE PIANO FINITIONS PLATEAU TOP FINISHES

### NOBILITATO / MÉLAMINE / MELAMINE

N05	Bianco matrix
N20	Natural halifax oak
N21	Pino jackson
N23	Cemento
N24	Ardesia
N25	Vintage chiaro
N30	Morera
N33	Resina silver
N34	Resina grigio cenere
N35	Rovere nodato caramel
N36	Olmo moka

### LACCATO / LAQUÉ / LACQUERED

Poroso aperto  
/ Pores ouverts / Open pore

Opaco  
/ Mat / Matt

Lucido  
/ Brilliant / High gloss

L31	L51	L01	Bianco luce
L32	L52		Bianco panna
L33	L53		Bianco vela
L34	L54		Grigio corda
L35	L55		Grigio canapa
L39	L59		Rosso aragosta
L40	L60		Tortora

### ROVERE IMPIALLACCIATO / PLACAGE CHÊNE / OAK VENEER

W01	Rovere naturale
W02	Rovere grigio
W03	Rovere tabacco
W04	Rovere nodato
W06	Rovere juta
W07	Rovere fumé

### VETRO / VERRE / GLASS

G01	Bianco
G02	Tortora
G03	Nero
G04	Bianco acidato
G05	Tortora acidato
G06	Nero acidato

### EFFETTO MALTA / EFFET-BÉTON / MORTAR-LOOK

E01	Corten black
E02	Corten gold
E03	Corten silver
E04	Metalli vissuti nichel
E05	Metalli vissuti rame
E06	Beton tortora
E07	Beton nero
E08	Beton grigio scuro
E09	Beton grigio chiaro
E10	Pietra spatolata tortora
E11	Pietra spatolata notte
E12	Pietra spatolata cenere
E13	Pietra spatolata perla
E14	Pietra spatolata antracite
E15	Pietra spatolata travertino
E17	Pietra spatolata ardesia alluminio
E19	Bianco assoluto

### CERAMICA / CÉRAMIQUE / CERAMIC

K01	Fokos sale
K02	Fokos terra
K03	Fokos piombo

LAMINAM®

## FINITURE BASE FINITIONS PIÉTEMENT BASE FINISHES

### METALLO / MÉTAUX / METALS

M02	Verniciato grisou goffrato
M03	Verniciato bianco opaco
M04	Verniciato nero opaco
M05	Cromo lucido
M07	Cromo opaco
M09	Cromo nero lucido
M10	Cromo nero opaco
M11	Verniciato grafite goffrato
M12	Verniciato tortora opaco
M19	Verniciato bronzo goffrato

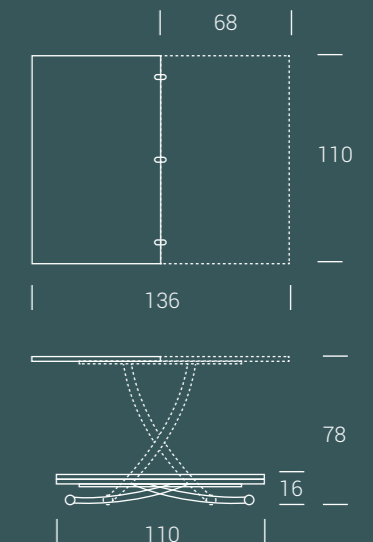

# ETOILE

ETOILE RICORDA LA DELICATEZZA, LA RAFFINATEZZA E LA GRAZIA DI UN BALLERINO CHE SI MUOVE SINUOSAMENTE. CON IL SUO PIANO IN CRISTALLO O CERAMICA È SINONIMO DI MODERNITÀ ED È L'IDEALE PER CHI VUOLE AGGIUNGERE UN PIZZICO DI PREZIOSA ELEGANZA IN SOGGIORNO. FUNZIONALITÀ, PRATICITÀ E FINEZZA RACCHIUSE IN SOLO TAVOLO.

Etoile rappelle la délicatesse, l'élégance et la grâce d'un bon danseur. Son plateau en verre ou céramique est synonyme de modernité et cette table est l'idéal pour ceux qui veulent ajouter une touche d'élégance dans le salon. Fonctionnalité, praticité et finesse dans un seul produit.

Etoile reminds the delicacy, refinement and grace of a dancer moving sinuously. Its glass or ceramic top is synonym of modernity and it is the ideal solution for people looking for elegance. Functionality, practicality and delicacy are embedded in one table.



16

**ETOILE**  
design Altacom

Base/Piédement/Base: verniciato grafite gofrato M11  
Piano/Plateau/Top: ceramica fokos piombo K03



ETOILE



## ETOILE



**Tavolino trasformabile in tavolo da pranzo, base in metallo, meccanismo a gas, regolabile in altezza al millimetro da cm 27 a cm 86, piano in vetro o ceramica, allunghe laterali a libro in nobilitato. Ruote a scomparsa.**

Table relevable en table de repas, piétement en métal, haussement par vérin-gaz, réglable en hauteur au millimètre de cm 27 à cm 86, plateau verre ou céramique, rallonges latérales à portefeuille en mélamine. Roulettes intégrées.

Transforming coffee table, it turns into a dining table. Metal frame, gas lifting device, millimetre-adjustable height from cm 27 to cm 86, glass or ceramic top, 2 side sliding folded extensions in melamine. Under-base wheels.

## FINITURE PIANO FINITIONS PLATEAU TOP FINISHES

### VETRO / VERRE / GLASS

- G01 Bianco
- G02 Tortora
- G03 Nero
- G04 Bianco acidato
- G05 Tortora acidato
- G06 Nero acidato

### CERAMICA / CÉRAMIQUE / CERAMIC

- K01 Fokos sale
- K02 Fokos terra
- K03 Fokos piombo
- K04 Noir desir lucido
- K05 Bianco statuario venato lucido

**LAMINAM**

## FINITURE BASE FINITIONS PIÉTEMENT BASE FINISHES

### METALLO / MÉTAUX / METALS

- M02 Verniciato grisou gofrato
- M03 Verniciato bianco opaco
- M04 Verniciato nero opaco
- M05 Cromo lucido
- M07 Cromo opaco
- M09 Cromo nero lucido
- M10 Cromo nero opaco
- M11 Verniciato grafite gofrato
- M12 Verniciato tortora opaco
- M19 Verniciato bronzo gofrato

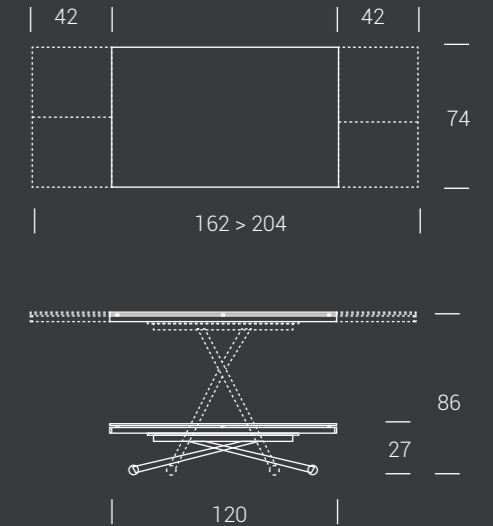

# GENIALE

IL TAVOLINO TRASFORMABILE PIÙ BASSO AL MONDO È GENIALE, DI NOME E DI FATTO. QUANDO È CHIUSO PUÒ FACILMENTE SCOMPARIRE SOTTO UN LETTO O A UN DIVANO, PER GUADAGNARE ULTERIORE SPAZIO IN SOGGIORNO, MENTRE QUANDO È APERTO È UNA COMODA POSTAZIONE DOVE POTER LAVORARE O PRANZARE. UN TAVOLO DAVVERO INTELLIGENTE.

La table relevable plus basse au monde, déjà dans son nom l'on identifie sa qualité principale. Si elle est toute basse, elle peut être placée sous un lit ou un canapé, au fin de gagner de la place dans le salon; si elle est toute haute, elle est une table de repas ou une table de travail très confortable. Une table vraiment...Géniale.

The lowest transforming table is Geniale. When closed, it can easily disappear under a bed or a couch, to gain even more space in the living room. When open, it's a solid workstation or dining table. A very smart solution.



17

**GENIALE**  
design Altacom

Base/Piédement/Base: verniciato grafite goffrato M11  
Piano/Plateau/Top: nobilitato pino jackson N21





## GENIALE

GENIALE, NELLA SUA POSIZIONE PIÙ BASSA PUÒ SCOMPARIRE SOTTO UN LETTO O A UN DIVANO, PER GUADAGNARE ULTERIORE SPAZIO!

EN POSITION BASSE LA GENIALE PEUT ÊTRE DISPARAÎTRE SOUS UN LIT OU UN CANAPÉ, POUR GAGNER DE LA PLACE SUPPLÉMENTAIRE.

GENIALE, IN ITS LOWER POSITION CAN DISAPPEAR UNDER A BED OR A COUCH, TO GAIN EVEN MORE SPACE!

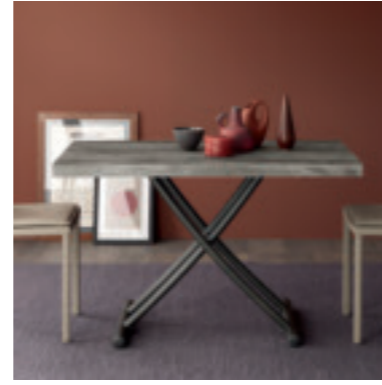

## FINITURE PIANO FINITIONS PLATEAU TOP FINISHES

### NOBILITATO / MÉLAMINE / MELAMINE

N05	Bianco matrix
N20	Natural halifax oak
N21	Pino jackson
N23	Cemento
N24	Ardesia
N25	Vintage chiaro
N30	Morera
N33	Resina silver
N34	Resina grigio cenere
N35	Rovere nodato caramel
N36	Olmo moka

### LACCATO / LAQUÉ / LACQUERED

### ROVERE IMPIALLACCIATO / PLACAGE CHÊNE / OAK VENEER

W01	Rovere naturale
W02	Rovere grigio
W03	Rovere tabacco
W04	Rovere nodato
W06	Rovere juta
W07	Rovere fumé

### Poros aperto / Pores ouverts / Open pore

L31	Bianco luce
L32	Bianco panna
L33	Bianco vela
L34	Grigio corda
L35	Grigio canapa
L39	Rosso aragosta
L40	Tortora

### EFFETTO MALTA / EFFET-BÉTON / MORTAR-LOOK

E01	Corten black
E02	Corten gold
E03	Corten silver
E04	Metalli vissuti nichel
E05	Metalli vissuti rame
E06	Beton tortora
E07	Beton nero
E08	Beton grigio scuro
E09	Beton grigio chiaro
E10	Pietra spatolata tortora
E11	Pietra spatolata notte
E12	Pietra spatolata cenere
E13	Pietra spatolata perla
E14	Pietra spatolata antracite
E15	Pietra spatolata travertino
E17	Pietra spatolata ardesia alluminio
E19	Bianco assoluto

Tavolino trasformabile in tavolo da pranzo, base in metallo, meccanismo a gas regolabile in altezza al millimetro da cm 11 a cm 75,5, piano in nobilitato, legno o effetto malta. Ruotea scomparsa e rotelle trasversali.

Table relevable en table de repas, piétement en métal, réglage en hauteur par vérin-gaz, réglable en hauteur au millimètre de cm 11 à cm 75,5, plateau en mélamine, bois ou effet-béton. Roulettes intégrées et roulettes transversales.

Transforming coffee table, it turns into a dining table. Metal frame, gas lifting device, millimetre-adjustable height from cm 11 to cm 75.5, melamine, stained wood or mortar-look top. Under-base wheels and side translation castors.

## FINITURE BASE FINITIONS PIÉTEMENT BASE FINISHES

### METALLO / MÉTAUX / METALS

M02	Verniciato grisou goffrato
M03	Verniciato bianco opaco
M04	Verniciato nero opaco
M05	Cromo lucido
M07	Cromo opaco
M09	Cromo nero lucido
M10	Cromo nero opaco
M11	Verniciato grafite goffrato
M12	Verniciato tortora opaco
M19	Verniciato bronzo goffrato

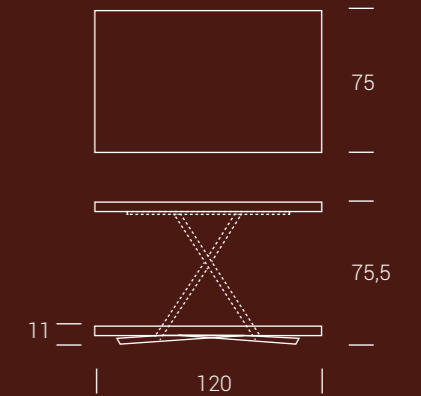

# C I A K

PER CHI CERCA UN TAVOLO SEMPLICE E POCO IMPEGNATIVO, CHE FA IL SUO DOVERE NELLA VITA DI TUTTI I GIORNI: CIAK È IL TAVOLO DALLO STILE "EASY", CONCRETO, PER CHI NON AMA I FRONZOLI E ADORA LA FUNZIONALITÀ DI UN TAVOLINO TRASFORMABILE DA VIVERE AL MASSIMO, SENZA PAURA DI SCIUPARLO.

Pour ceux qui veulent une table simple et fonctionnelle, une table qui fait son devoir au quotidien: Ciak est la table au style facile et concret, pour ceux qui aiment le caractère pratique d'une table relevable à vivre au maximum, sans la peur de la gâcher.

This table is an easy going solution to exploit in the everyday routine. Ciak has an easy and pragmatic style that is best suited for people who don't like frills but are more attentive to function and the possibility of exploiting the table at most without ruing it.







18  
**CIAK**  
design Altacom

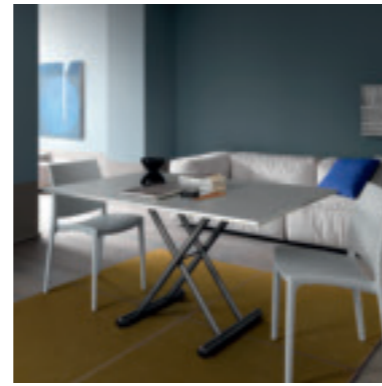

**FINITURE PIANO**  
**FINITIONS PLATEAU**  
**TOP FINISHES**

**NOBILITATO**  
**/ MÉLAMINE**  
**/ MELAMINE**

- N05 Bianco matrix
- N20 Natural halifax oak
- N21 Pino jackson
- N23 Cemento
- N24 Ardesia
- N25 Vintage chiaro
- N30 Morera
- N33 Resina silver
- N34 Resina grigio cenere
- N35 Rovere nodato caramel
- N36 Olmo moka

**LACCATO**  
**/ LAQUÉ**  
**/ LACQUERED**

**Poros aperto**  
 / Pores ouverts / Open pore

- L31 Bianco luce
- L32 Bianco panna
- L33 Bianco vela
- L34 Grigio corda
- L35 Grigio canapa
- L39 Rosso aragosta
- L40 Tortora

**ROVERE IMPIALLACCIATO**  
**/ PLACAGE CHÊNE**  
**/ OAK VENEER**

- W01 Rovere naturale
- W02 Rovere grigio
- W03 Rovere tabacco
- W04 Rovere nodato
- W06 Rovere juta
- W07 Rovere fumé

**VETRO**  
**/ VERRE**  
**/ GLASS**

- G01 Bianco
- G02 Tortora
- G03 Nero
- G04 Bianco acidato
- G05 Tortora acidato
- G06 Nero acidato

**EFFETTO MALTA**  
**/ EFFET-BÉTON**  
**/ MORTAR-LOOK**

- E01 Corten black
- E02 Corten gold
- E03 Corten silver
- E04 Metalli vissuti nichel
- E05 Metalli vissuti rame
- E06 Beton tortora
- E07 Beton nero
- E08 Beton grigio scuro
- E09 Beton grigio chiaro
- E10 Pietra spatolata tortora
- E11 Pietra spatolata notte
- E12 Pietra spatolata cenere
- E13 Pietra spatolata perla
- E14 Pietra spatolata antracite
- E15 Pietra spatolata travertino
- E17 Pietra spatolata ardesia alluminio
- E19 Bianco assoluto

**CERAMICA**  
**/ CÉRAMIQUE**  
**/ CERAMIC**

- K01 Fokos sale
- K02 Fokos terra
- K03 Fokos piombo

**LAMINAM®**

**Tavolino trasformabile in tavolo da pranzo, base in metallo, meccanismo a gas regolabile in altezza al millimetro da cm 25 a cm 76, piano raddoppiabile a libro in nobilitato, vetro, legno, effetto-malta o ceramica. Ruote a scomparsa. Opzione rotelle trasversali.**

Table relevable en table de repas, piétement en métal, réglage en hauteur par vérin-gaz, réglable en hauteur au millimètre de cm 25 à cm 76, plateau portefeuille en mélamine, verre, bois, effet-béton ou céramique. Roulettes intégrées. Option roulettes transversales.

Metal frame transforming coffee table, it turns into a dining table, gas lifting device, millimetre-adjustable height from cm 25 to cm 76, melamine, glass, stained wood, mortar-look or ceramic doubling top. Under-base wheels. Side translation castors option.

**FINITURE BASE**  
**FINITIONS PIÉTEMENT**  
**BASE FINISHES**

**METALLO**  
**/ MÉTAUX**  
**/ METALS**

- M02 Verniciato grisou goffrato
- M03 Verniciato bianco opaco
- M04 Verniciato nero opaco
- M05 Cromo lucido
- M07 Cromo opaco
- M09 Cromo nero lucido
- M10 Cromo nero opaco
- M11 Verniciato grafite goffrato
- M12 Verniciato tortora opaco
- M19 Verniciato bronzo goffrato

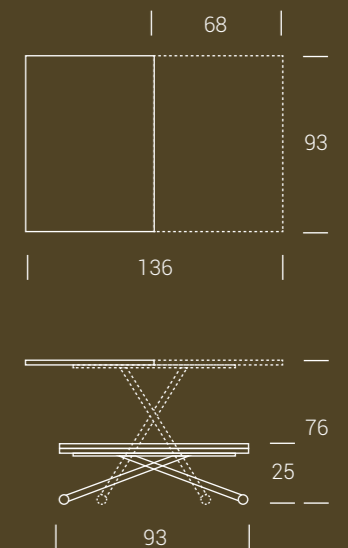

## CARRONDE

CARRONDE È UN TAVOLINO TRASFORMABILE INNOVATIVO, PERCHÉ INVECE DI ALLUNGARSI, SI ESPANDE IN LARGHEZZA. LA PARTICOLARE FORMA "A BOTTE" DA CHIUSO, CHE DIVENTA UN RETTANGOLO CON DUE LATI LEGGERMENTE ARROTONDATI DA APERTO, È LA MARCIA IN PIÙ CHE LO RENDE UNICO. IDEALE PER CHI È ALLA RICERCA DI UNA STRUTTURA DIVERSA DAL SOLITO.

Carronde est une table relevable innovante, qui s'ouvre en largeur: les deux rallonges coulissantes et utilisables séparément se cachent sous le plateau, la forme spéciale "tonneau" tant dans la version table de salon, que dans la version table de salle à manger. Unique, pensée pour ceux qui recherchent du "non déjà vu".

Carronde is an innovative transforming table that instead of extending in length extends in width. Its peculiar barrel shape, when it is closed, becomes a rectangle with two smoothed out sides when open. This characteristic makes it a unique piece. It's ideal for those who are looking for something unusual.



CARRONDE



19

**CARRONDE**  
design Altacom





## CARRONDE



### FINITURE PIANO FINITIONS PLATEAU TOP FINISHES

#### NOBILITATO / MÉLAMINE / MELAMINE

N05	Bianco matrix
N20	Natural halifax oak
N21	Pino jackson
N23	Cemento
N24	Ardesia
N25	Vintage chiaro
N30	Morera
N33	Resina silver
N34	Resina grigio cenere
N35	Rovere nodato caramel
N36	Olmo moka

#### LACCATO / LAQUÉ / LACQUERED

Poro aperto  
/ Pores ouverts / Open pore

L31	Bianco luce
L32	Bianco panna
L33	Bianco vela
L34	Grigio corda
L35	Grigio canapa
L39	Rosso aragosta
L40	Tortora

#### ROVERE IMPIALLACCIATO / PLACAGE CHÊNE / OAK VENEER

W01	Rovere naturale
W02	Rovere grigio
W03	Rovere tabacco
W04	Rovere nodato
W06	Rovere juta
W07	Rovere fumé

Tavolino trasformabile in tavolo da pranzo, base in metallo, meccanismo a gas, regolabile in altezza al millimetro da cm 27 a cm 86, piano a botte in nobilitato o legno, prolunghe indipendenti scorrevoli sottopiano. Ruote a scomparsa.

Table relevable en table de repas, piétement en métal, haussement par vérin-gaz, réglable en hauteur au millimètre de cm 27 à cm 86, plateau tonneau en mélamine ou bois, rallonges indépendantes coulissantes sous-plateau. Roulettes intégrées.

Transforming coffee table, it turns into a dining table. Metal frame, gas lifting device, millimetre-adjustable height from cm 27 to cm 86, melamine or stained wood barrel top, independent under-top sliding extensions. Under-base wheels.

### FINITURE BASE FINITIONS PIÉTEMENT BASE FINISHES

#### METALLO / MÉTAUX / METALS

M02	Verniciato grisou goffrato
M03	Verniciato bianco opaco
M04	Verniciato nero opaco
M05	Cromo lucido
M07	Cromo opaco
M09	Cromo nero lucido
M10	Cromo nero opaco
M11	Verniciato grafite goffrato
M12	Verniciato tortora opaco
M15	Oro lucido
M19	Verniciato bronzo goffrato

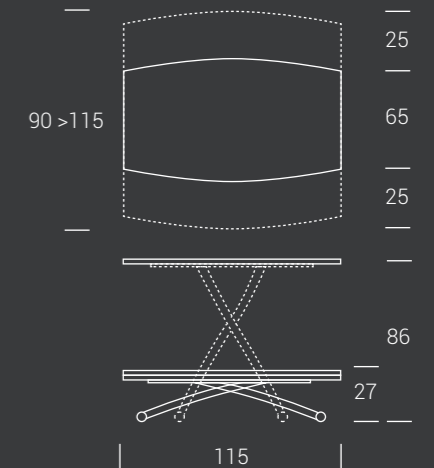

# SAKURA

CON LE SUE FORME MORBIDE E SINUOSE, SAKURA PRENDE ISPIRAZIONE DAL FIORE DI CILIEGIO, CERCANDO DI RICREARNE LA DELICATEZZA E LA BELLEZZA. IL RISULTATO È UN TAVOLINO FUNZIONALE CHE RADDOPPIA IL SUO PIANO IN LARGHEZZA E CHE ALLO STESSO TEMPO VANTA UN'ESTETICA ESTREMAMENTE RAFFINATA, PER CHI RICERCA QUEL PIZZICO DI DESIGN IN PIÙ.

Avec ses lignes sinueuses, douces et raffinées, Sakura s'inspire de la fleur de cerisier, d'où la table hérite le nom japonais, en essayant d'imiter sa délicatesse et beauté. Le résultat est cette table avec le plateau portefeuille, fonctionnelle, au goût léger, pour une touche d'élégance dans le décor.

With its sinuous, soft and delicate shapes, Sakura is inspired by the cherry blossom, from which it inherits the name and whose beauty and refinement try to replicate. The result is a functional table that doubles its size in width and at the same time maintains a refined style, for those who want a more polished design.



20

**SAKURA**  
design Altacom

Base/Piètements/Base: verniciato nero opaco M04  
Piano/Plateau/Top: laccato poro aperto rosso aragosta L39







**Tavolino trasformabile in tavolo da pranzo, base in metallo, meccanismo a gas, regolabile in altezza al millimetro da cm 35 a cm 75, piano raddoppiabile a libro in nobilitato, laccato, legno, effetto malta, vetro o ceramica.**

Table relevable en table de repas, piétement en métal, haussement par vérin-gaz, réglable en hauteur au millimètre de cm 35 à cm 75, plateau portefeuille en mélamine, laqué, bois, effet-béton, verre ou céramique.

Transforming coffee table, it turns into a dining table. Metal frame, gas lifting device, millimetre-adjustable height from cm 35 to cm 75, melamine, glass, lacquered, stained wood, mortar-look or ceramic doubling top.

**FINITURE PIANO**  
**FINITIONS PLATEAU**  
**TOP FINISHES**

**NOBILITATO**  
**/ MÉLAMINE**  
**/ MELAMINE**

- N05 Bianco matrix
- N20 Natural halifax oak
- N21 Pino jackson
- N23 Cemento
- N24 Ardesia
- N25 Vintage chiaro
- N30 Morera
- N33 Resina silver
- N34 Resina grigio cenere
- N35 Rovere nodato caramel
- N36 Olmo moka

**LACCATO**  
**/ LAQUÉ**  
**/ LACQUERED**

**Poroso aperto**  
**/ Pores ouverts / Open pore**

**Opaco**  
**/ Mat / Matt**

**Lucido**  
**/ Brilliant / High gloss**

- |     |     |     |                |
|-----|-----|-----|----------------|
| L31 | L51 | L01 | Bianco luce    |
| L32 | L52 |     | Bianco panna   |
| L33 | L53 |     | Bianco vela    |
| L34 | L54 |     | Grigio corda   |
| L35 | L55 |     | Grigio canapa  |
| L39 | L59 |     | Rosso aragosta |
| L40 | L60 |     | Tortora        |

**ROVERE IMPIALLACCIATO**  
**/ PLACAGE CHÊNE**  
**/ OAK VENEER**

- W01 Rovere naturale
- W02 Rovere grigio
- W03 Rovere tabacco
- W04 Rovere nodato
- W06 Rovere juta
- W07 Rovere fumé

**VETRO**  
**/ VERRE**  
**/ GLASS**

- G01 Bianco
- G02 Tortora
- G03 Nero
- G04 Bianco acidato
- G05 Tortora acidato
- G06 Nero acidato

**EFFETTO MALTA**  
**/ EFFET-BÉTON**  
**/ MORTAR-LOOK**

- E01 Corten black
- E02 Corten gold
- E03 Corten silver
- E04 Metalli vissuti nichel
- E05 Metalli vissuti rame
- E06 Beton tortora
- E07 Beton nero
- E08 Beton grigio scuro
- E09 Beton grigio chiaro
- E10 Pietra spatolata tortora
- E11 Pietra spatolata notte
- E12 Pietra spatolata cenere
- E13 Pietra spatolata perla
- E14 Pietra spatolata antracite
- E15 Pietra spatolata travertino
- E17 Pietra spatolata ardesia alluminio
- E19 Bianco assoluto

**CERAMICA**  
**/ CÉRAMIQUE**  
**/ CERAMIC**

- K01 Fokos sale
- K02 Fokos terra
- K03 Fokos piombo

LAMINAM®

**FINITURE BASE**  
**FINITIONS PIÉTEMENT**  
**BASE FINISHES**

**METALLO**  
**/ MÉTAUX**  
**/ METALS**

- M02 Verniciato grisou gofrato
- M03 Verniciato bianco opaco
- M04 Verniciato nero opaco
- M05 Cromo lucido
- M07 Cromo opaco
- M09 Cromo nero lucido
- M10 Cromo nero opaco
- M11 Verniciato grafite gofrato
- M12 Verniciato tortora opaco
- M19 Verniciato bronzo gofrato

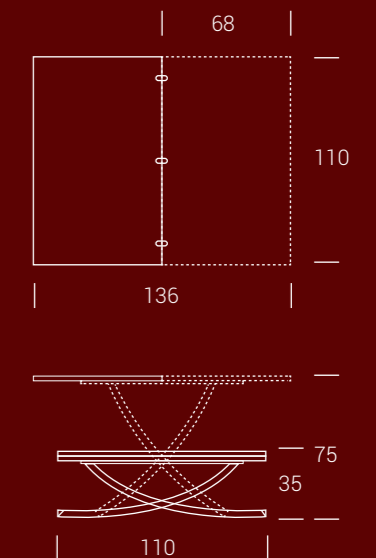

# UNIVERSE

IL NOME DI QUESTO TAVOLO PREANNUNCIA LA SUA QUALITÀ MIGLIORE: L'UNIVERSALITÀ, LA CAPACITÀ DI ADATTARSI A STILI, GUSTI ED ESIGENZE DIFFERENTI. UNIVERSE È UN VERO EVERGREEN, RAFFINATO COME TAVOLINO DA SOGGIORNO E PRATICISSIMO TAVOLO DA PRANZO.

Déjà dans son nom l'on identifie sa meilleure qualité: l'universalité, la capacité d'adaptation aux styles, aux goûts et aux besoins différents. Universe est un objet intemporel, table basse très élégante et table de repas très pratique.

The name of this table lets us know in advance its best quality: universality, the capability of adapting to every style, taste, and need. Universe is an evergreen model, a refined coffee table and a practical dining table.



21

**UNIVERSE**  
design Altacom

Base/Piédement/Base: cromo lucido M05  
Piano/Plateau/Top: rovere nodato W04









**Tavolino trasformabile in tavolo da pranzo, base in metallo, meccanismo a gas, regolabile in altezza al millimetro da cm 27 a cm 81, piano raddoppiabile a libro in nobilitato, laccato, legno, effetto malta, vetro o ceramica. Ruote a scomparsa.**

Table relevable en table de repas, piétement en métal, haussement par vérin-gaz, réglable en hauteur au millimètre de cm 27 à cm 81, plateau portefeuille mélamine, laqué, bois, effet-béton, verre ou céramique. Roulettes intégrées.

Transforming coffee table, it turns into a dining table. Metal frame, gas lifting device, millimetre-adjustable height from cm 27 to cm 81, melamine, glass, lacquered, stained wood, mortar-look, or ceramic doubling top. Under-base wheels.

**FINITURE PIANO**  
**FINITIONS PLATEAU**  
**TOP FINISHES**

**NOBILITATO**  
**/ MÉLAMINE**  
**/ MELAMINE**

- N05 Bianco matrix
- N20 Natural halifax oak
- N21 Pino jackson
- N23 Cemento
- N24 Ardesia
- N25 Vintage chiaro
- N30 Morera
- N33 Resina silver
- N34 Resina grigio cenere
- N35 Rovere nodato caramel
- N36 Olmo moka

**LACCATO**  
**/ LAQUÉ**  
**/ LACQUERED**

**Poroso aperto**  
**/ Pores ouverts / Open pore**

**Opaco**  
**/ Mat / Matt**

**Lucido**  
**/ Brilliant / High gloss**

- |     |     |     |                |
|-----|-----|-----|----------------|
| L31 | L51 | L01 | Bianco luce    |
| L32 | L52 |     | Bianco panna   |
| L33 | L53 |     | Bianco vela    |
| L34 | L54 |     | Grigio corda   |
| L35 | L55 |     | Grigio canapa  |
| L39 | L59 |     | Rosso aragosta |
| L40 | L60 |     | Tortora        |

**ROVERE IMPIALLACCIATO**  
**/ PLACAGE CHÊNE**  
**/ OAK VENEER**

- W01 Rovere naturale
- W02 Rovere grigio
- W03 Rovere tabacco
- W04 Rovere nodato
- W06 Rovere juta
- W07 Rovere fumé

**VETRO**  
**/ VERRE**  
**/ GLASS**

- G01 Bianco
- G02 Tortora
- G03 Nero
- G04 Bianco acidato
- G05 Tortora acidato
- G06 Nero acidato

**EFFETTO MALTA**  
**/ EFFET-BÉTON**  
**/ MORTAR-LOOK**

- E01 Corten black
- E02 Corten gold
- E03 Corten silver
- E04 Metalli vissuti nichel
- E05 Metalli vissuti rame
- E06 Beton tortora
- E07 Beton nero
- E08 Beton grigio scuro
- E09 Beton grigio chiaro
- E10 Pietra spatolata tortora
- E11 Pietra spatolata notte
- E12 Pietra spatolata cenere
- E13 Pietra spatolata perla
- E14 Pietra spatolata antracite
- E15 Pietra spatolata travertino
- E17 Pietra spatolata ardesia alluminio
- E19 Bianco assoluto

**CERAMICA**  
**/ CÉRAMIQUE**  
**/ CERAMIC**

- K01 Fokos sale
- K02 Fokos terra
- K03 Fokos piombo

LAMINAM®

**FINITURE BASE**  
**FINITIONS PIÉTEMENT**  
**BASE FINISHES**

**METALLO**  
**/ MÉTAUX**  
**/ METALS**

- M02 Verniciato grisou goffrato
- M03 Verniciato bianco opaco
- M04 Verniciato nero opaco
- M05 Cromo lucido
- M07 Cromo opaco
- M09 Cromo nero lucido
- M10 Cromo nero opaco
- M11 Verniciato grafite goffrato
- M12 Verniciato tortora opaco
- M15 Oro lucido
- M19 Verniciato bronzo goffrato

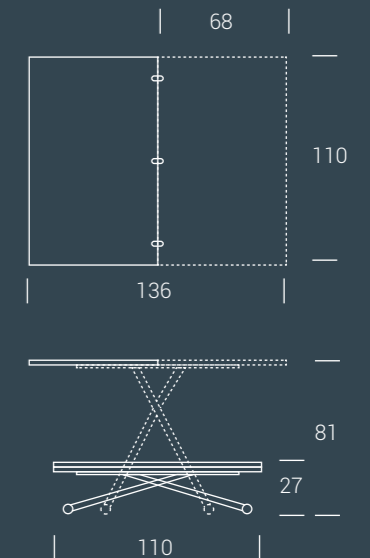

## REDONDO

UN TAVOLINO DA SALOTTO CON QUATTRO SPIGOLI, CHE DIVENTA UN TAVOLO DA PRANZO SENZA ANGOLI. REDONDO È DAVVERO INCREDIBILE: LA SOLUZIONE IDEALE PER CHI PROPRIO NON VUOLE RINUNCIARE AL CALORE E ALL'OSPITALITÀ DEL TAVOLO ROTONDO PUR AVENDO POCO SPAZIO A DISPOSIZIONE.

Une table relevable en table de repas, au design rond en position ouverte. Redondo est vraiment incroyable: la solution idéale pour ceux qui aiment la chaleur et l'hospitalité de la table ronde, bien que les espaces disponibles sont limitées.

A coffee table with four corners, which turns into a dining table without angles. Redondo is an incredible solution for people who love the warmth and hospitality of a round table even when small space is available.



22

**REDONDO**  
design Altacom

Base/Pièment/Base: verniciato grafite gofrato M11  
Piano/Plateau/Top: laccato poro aperto bianco vela L33

REDONDO





## REDONDO



### FINITURE PIANO FINITIONS PLATEAU TOP FINISHES

#### NOBILITATO / MÉLAMINE / MELAMINE

N05	Bianco matrix
N20	Natural halifax oak
N21	Pino jackson
N23	Cemento
N24	Ardesia
N25	Vintage chiaro
N30	Morera
N33	Resina silver
N34	Resina grigio cenere
N35	Rovere nodato caramel
N36	Olmo moka

#### LACCATO / LAQUÉ / LACQUERED

Poro aperto  
/ Pores ouverts / Open pore

L31	Bianco luce
L32	Bianco panna
L33	Bianco vela
L34	Grigio corda
L35	Grigio canapa
L39	Rosso aragosta
L40	Tortora

#### ROVERE IMPIALLACCIATO / PLACAGE CHÊNE / OAK VENEER

W01	Rovere naturale
W02	Rovere grigio
W03	Rovere tabacco
W04	Rovere nodato
W06	Rovere juta
W07	Rovere fumé

**Tavolino trasformabile in tavolo da pranzo, base in metallo, meccanismo a gas, regolabile in altezza al millimetro da cm 27 a cm 84, piano rotondo in nobilitato o legno, prolunghe indipendenti scorrevoli sottopiano. Ruote a scomparsa.**

Table relevable en table de repas, piétement en métal, haussement par vérin-gaz, réglable en hauteur au millimètre de cm 27 à cm 84, plateau rond en mélamine ou bois, rallonges indépendantes coulissantes sous-plateau. Roulettes intégrées.

Transforming coffee table, it turns into a dining table. Metal frame, gas lifting device, millimetre-adjustable height from cm 27 to cm 84, melamine or stained wood round top, independent under-top sliding extensions. Under-base wheels.

### FINITURE BASE FINITIONS PIÉTEMENT BASE FINISHES

#### METALLO / MÉTAUX / METALS

M02	Verniciato grisou goffrato
M03	Verniciato bianco opaco
M04	Verniciato nero opaco
M05	Cromo lucido
M07	Cromo opaco
M09	Cromo nero lucido
M10	Cromo nero opaco
M11	Verniciato grafite goffrato
M12	Verniciato tortora opaco
M15	Oro lucido
M19	Verniciato bronzo goffrato

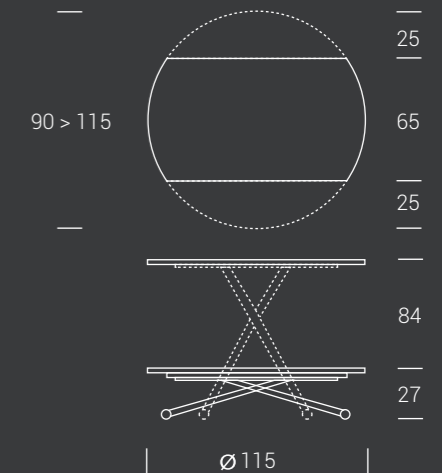

# DAVINCI

GENIALE, COME IL NOME A CUI SI ISPIRA, DA VINCI È UN COMPLEMENTO D'ARREDO ORIGINALE ED ESCLUSIVO, MA SE A PRIMA VISTA LA SUA FORMA COMPATTA EVOCA UNA VALIGIA, IL VIAGGIO CHE È IN GRADO DI INTRAPRENDERE È SORPRENDENTE. UN PICCOLO SPOSTAMENTO DALLA PARETE IN CENTRO STANZA E POCCHI MOVIMENTI TRASFORMANO UNA CONSOLLE IN UN PRATICISSIMO TAVOLO DA PRANZO: LA STRUTTURA LEGGERA, MA ESTREMAMENTE STABILE, SORREGGE IL PIANO REALIZZATO IN ROVERE MASSICCIO DALL'ASPETTO ESTETICO VINTAGE CHE SUGGERISCE L'ESPERIENZA IN "MATERIA".

Autant géniale que le nom qui l'inspire, da vinci est une pièce d'ameublement originale et unique, mais, si à première vue ses formes compactes évoquent une valise, le voyage qu'elle sait aborder est tout de même surprenant. Un petit déplacement du mur au centre de la pièce et quelques simples mouvements transforment cette console en une table repas: sa structure légère, mais très stable, soutient le plateau en vrai chêne vieux au goût "vintage" qui laisse entendre de l'expérience dans le domaine.

As ingenious as the name to which it's inspired, da vinci is an original and exclusive furnishing, but if at first glance its shape is evoking a luggage, the trip it can take is astonishing. A small displacement from the wall to the room center and a few easy movements turn the console in a practical dining table: its light, but extremely stable structure, is perfectly supporting the top made by real old oak recalling a vintage look and implying a certain experience on the subject as well.



23

**DAVINCI**  
design Altacom

Base/Piètement/Base: verniciato grafite goffrato M11  
Piano/Plateau/Top: rovere vecchio massiccio grigio W33







23  
**DAVINCI**  
design Altacom





# DAVINCI / SHELF



## FINITURE PIANO FINITIONS PLATEAU TOP FINISHES

### NOBILITATO / MÉLAMINE / MELAMINE

- N05 Bianco matrix
- N20 Natural halifax oak
- N21 Pino jackson
- N23 Cemento
- N24 Ardesia
- N25 Vintage chiaro
- N30 Morera
- N33 Resina silver
- N34 Resina grigio cenere
- N35 Rovere nodato caramel
- N36 Olmo moka

### LACCATO / LAQUÉ / LACQUERED

Poro aperto  
/ Pores ouverts / Open pore

- L31 Bianco luce
- L32 Bianco panna
- L33 Bianco vela
- L34 Grigio corda
- L35 Grigio canapa
- L39 Rosso aragosta
- L40 Tortora

### ROVERE IMPIALLACCIATO / PLACAGE CHÊNE / OAK VENEER

- W01 Rovere naturale
- W02 Rovere grigio
- W03 Rovere tabacco
- W04 Rovere nodato
- W06 Rovere juta
- W07 Rovere fumé

### LEGNO MASSICCIO / BOISS MASSIF / SOLID WOOD

- W21 Rovere vecchio massiccio termotrattato
- W32 Rovere vecchio massiccio naturale
- W33 Rovere vecchio massiccio grigio
- W34 Larice fresato

### EFFETTO MALTA / EFFET-BÉTON / MORTAR-LOOK

- E01 Corten black
- E02 Corten gold
- E03 Corten silver
- E04 Metalli vissuti nichel
- E05 Metalli vissuti rame
- E06 Beton tortora
- E07 Beton nero
- E08 Beton grigio scuro
- E09 Beton grigio chiaro
- E10 Pietra spatolata tortora
- E11 Pietra spatolata notte
- E12 Pietra spatolata cenere
- E13 Pietra spatolata perla
- E14 Pietra spatolata antracite
- E15 Pietra spatolata travertino
- E17 Pietra spatolata ardesia alluminio
- E19 Bianco assoluto

Consolle estensibile, struttura in metallo, piani apribili a compasso in nobilitato, legno o effetto malta, due prolunghe interne a libro.

Console extensible, structure en métal, plateaux pivotants en mélamine, bois, ou effet-béton, 2 rallonges intégrées portefeuille.

Metal frame extending console-table, pivotable tops in melamine, wood or mortar-look. 2 inside folded extensions.

## FINITURE BASE FINITIONS PIÉTEMENT BASE FINISHES

### METALLO / MÉTAUX / METALS

M11 Verniciato grafite gofrato

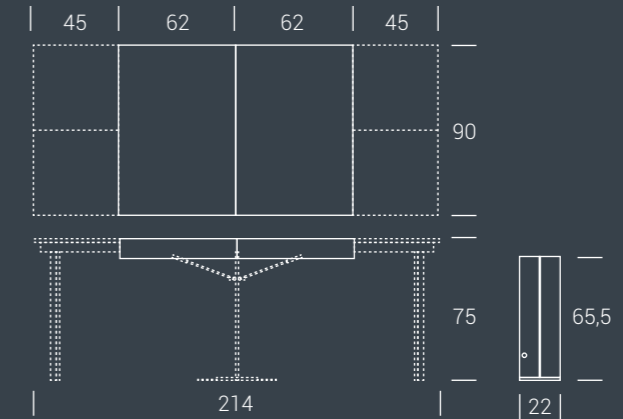

### DAVINCI SHELF OPTIONAL

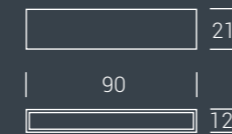

Mensola in nobilitato, legno o effetto malta.

Etagère en mélamine, bois ou effet-béton.

Shelf in melamine, wood or mortar-look.

# GENESI

GENESI È LA CONSOLLE DI NUOVA GENERAZIONE, IL DESIGN ESPRIME LA SUA FORMA SCULTOREA ESALTATA DALLA STRUTTURA PORTANTE IN METALLO CHE CONVERGE LE SUE LINEE IN UN NODO CENTRALE. LA SUA PERFETTA SIMMETRIA SI ESTENDE COME IN UN ABBRACCIO A SOSTEGNO DEL PIANO. DA CONSOLLE A TAVOLO DA PRANZO SI TRASFORMA SVILUPPANDOSI IN TUTTA LA SUA ESTENSIONE PER OSPITARE DA 4 AD 8 POSTI, L'IMPATTO SCENICO È ESCLUSIVO E FORTEMENTE CARATTERIZZANTE. GENESI, QUANDO L'EVOLUZIONE DELLA FORMA INCIDE SULLO SPAZIO PER CREARE VALORE E OSPITALITÀ.

Genesi est une console de nouvelle génération, le design exprime sa forme sculpturale, glorifiée par sa structure en métal avec ses lignes convergentes vers le nœud central. Sa parfaite symétrie soutient le plateau, comme dans un câlin. Elle se transforme de console à table repas, en s'étendant sur toute sa longueur, pour accueillir jusqu'à 8 personnes. Sa présence est exclusive et très caractérisant. Genesi, lors que l'évolution de la forme touche l'espace pour créer de la valeur et de l'hospitalité.

Genesi is a new generation console, whose design expresses its sculptural shape. The lines of its metal carrying structure converge in a central hub. its perfect simmetry extends like an arm that sustains the top. Genesi transforms from console into a dining table that can host up to 8 people. The scenic effect is exclusive and distinguishing. Genesi, the evolution of shape that affects space to create value and hospitality.



24

**GENESI**  
design Riccardo Buscato

**Base/Piédement/Base:** verniciato bronzo goffrato M19  
**Piano/Plateau/Top:** nobilitato rovere nodato caramél N35





# GENESI



GENESI, NELLA SUA MASSIMA ESTENSIONE, SI AVVALE DI UN SOSTEGNO CENTRALE CHE ASSICURA UNA SOLIDA BASE DI APPOGGIO SENZA COMPROMETTERE IL RIGORE L'ESTETICO CHE CARATTERIZZA LE FORME E ACCOMPAGNA LO STUDIO ATTENTO DEI FATTORI LEGATI ALL' ERGONOMIA.

Genesi, lorsqu'elle est ouverte, est dotée d'un pied de renforce qui assure sa stabilité, sans compromettre la rigueur de son esthétique et de ses formes.

Genesi, in its maximum extension, takes advantage of a central support that guarantees a solid base without compromising the aesthetic accuracy.



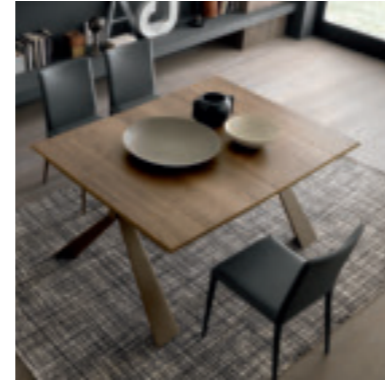
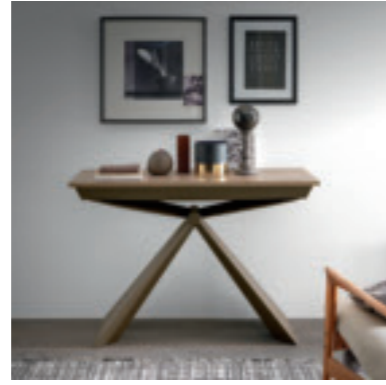

**FINITURE PIANO**  
**FINITIONS PLATEAU**  
**TOP FINISHES**

**NOBILITATO**  
**/ MÉLAMINE**  
**/ MELAMINE**

- N05 Bianco matrix
- N20 Natural halifax oak
- N21 Pino jackson
- N23 Cemento
- N24 Ardesia
- N25 Vintage chiaro
- N30 Morera
- N33 Resina silver
- N34 Resina grigio cenere
- N35 Rovere nodato caramel
- N36 Olmo moka

**LACCATO**  
**/ LAQUÉ**  
**/ LACQUERED**

**Poro aperto**  
 / Pores ouverts / Open pore

- L31 Bianco luce
- L32 Bianco panna
- L33 Bianco vela
- L34 Grigio corda
- L35 Grigio canapa
- L39 Rosso aragosta
- L40 Tortora

**EFFETTO MALTA**  
**/ EFFET-BÉTON**  
**/ MORTAR-LOOK**

- E01 Corten black
- E02 Corten gold
- E03 Corten silver
- E04 Metalli vissuti nichel
- E05 Metalli vissuti rame
- E06 Beton tortora
- E07 Beton nero
- E08 Beton grigio scuro
- E09 Beton grigio chiaro
- E10 Pietra spatolata tortora
- E11 Pietra spatolata notte
- E12 Pietra spatolata cenere
- E13 Pietra spatolata perla
- E14 Pietra spatolata antracite
- E15 Pietra spatolata travertino
- E17 Pietra spatolata ardesia alluminio
- E19 Bianco assoluto

**ROVERE IMPIALLACCIATO**  
**/ PLACAGE CHÊNE**  
**/ OAK VENEER**

- W01 Rovere naturale
- W02 Rovere grigio
- W03 Rovere tabacco
- W04 Rovere nodato
- W06 Rovere juta
- W07 Rovere fumé

**Consolle estensibile, struttura in metallo, meccanismo telescopico in alluminio, piano in nobilitato, laccato, legno o effetto malta, 3 o 5 allunghe. Gambe centrali di supporto.**

Console extensible, structure en métal, mécanique télescopique en aluminium, plateau mélamine, laqué, bois ou effet-béton, 3 ou 5 rallonges. Pieds centraux de support.

Metal frame extending console-table, aluminium telescopic mechanism, top in melamine, lacquered, wood or mortar-look, 3 or 5 extensions. Central supporting legs.

**FINITURE BASE**  
**FINITIONS PIÉTEMENT**  
**BASE FINISHES**

**METALLO**  
**/ MÉTAUX**  
**/ METALS**

- M02 Verniciato grisou goffrato
- M03 Verniciato bianco opaco
- M04 Verniciato nero opaco
- M11 Verniciato grafite goffrato
- M12 Verniciato tortora opaco
- M19 Verniciato bronzo goffrato

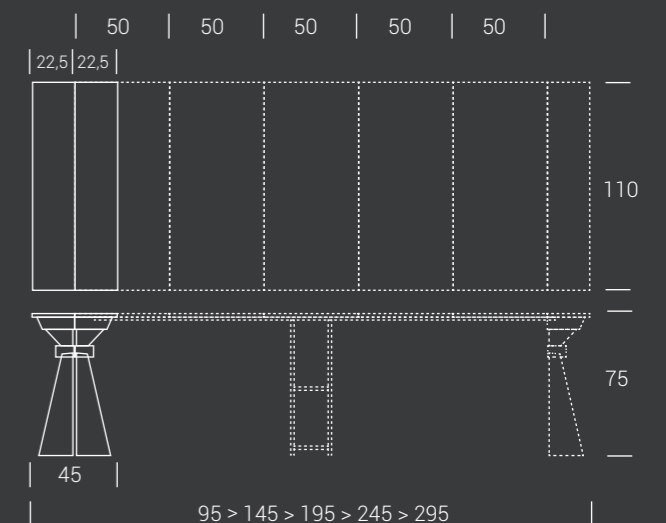
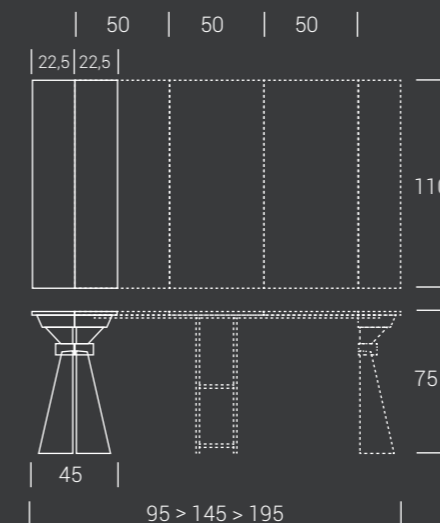

# ASTORIA



ASTORIA INAUGURA UNO STILE INTERPRETATIVO BASATO SULL'INTEGRAZIONE DI UN MATERIALE VINTAGE, PRESENTE SUL PIANO E ACCOSTANDOSI ALLA STRUTTURA IN METALLO GRAFITE CHE NE DETERMINA IL CARATTERE. UN CARATTERE MODERNO E DECISO NEL QUALE LA PAROLA D'ORDINE È METAMORFOSI. LA TRASFORMAZIONE, DA CONSOLLE A TAVOLO DA PRANZO APPARTIENE ALLA FILOSOFIA ALTACOM PER CUI TUTTO È IN MOVIMENTO PER ASSOLVERE AD UNA DETERMINATA FUNZIONE RAGGIUNGENDO CANONI ESTETICI APPREZZABILI.

Astoria donne cours à un style d'interprétation basé sur l'intégration d'un matériel "vintage", utilisé sur le plateau, et en s'approchant à la structure en métal graphite qui en détermine le caractère. Un caractère moderne et résolu où le mot de passe est métamorphose. La transformation de console à table repas appartient à la philosophie altacom selon la quelle tout est en mouvement pour accomplir une fonction déterminée en atteignant des appréciables valeurs esthétiques.

Astoria inaugurates an interpretative style based on the integration of a vintage material, utilized for the top, and accompanying the graphite metal structure which determines its character. A modern and firm character for which the password is metamorphosis. The transformation from console to dining table belongs to the altacom philosophy where everything is in movement to assolve a determined function through remarkable aesthetic values.

25

**ASTORIA**  
design Altacom

**Base/Piédement/Base:** verniciato grafite goffrato M11  
**Piano/Plateau/Top:** nobilitato vintage chiaro N25





# ASTORIA



25

**ASTORIA**  
design Altacom

IL SUPPORTO IN METALLO POSTO NELLA ZONA CENTRALE SOTTO AL PIANO, SOSTIENE, IN TOTALE SICUREZZA E SENZA INGOMBRO, IL PIANO NELLE SUE MASSIME ESTENSIONI. ASTORIA, MINIMO INGOMBRO NELLA SUA VERSIONE CONSOLLE A PARETE, MASSIMA CONVIVIALITÀ NELL'ACCOGLIERE FINO A DIECI OSPITI INTORNO AL TAVOLO.

Le support en métal situé au milieu sous le plateau soutient, en toute sécurité et sans contraintes, le plateau lors de son complète extension. Astoria, encombrement limité en position fermée, extrême convivialité en accueillant jusqu'à dix personnes autour de la table.

The metal support in the middle under the top, is holding up the top once completely extended, in complete safety and without constraints. Astoria, minimum encumbrance when closed, maximum conviviality by accomodating up to ten guests at the table.



ASTORIA



# A S T O R I A



## FINITURE PIANO FINITIONS PLATEAU TOP FINISHES

### NOBILITATO / MÉLAMINE / MELAMINE

- N05 Bianco matrix
- N20 Natural halifax oak
- N21 Pino jackson
- N23 Cemento
- N24 Ardesia
- N25 Vintage chiaro
- N30 Morera
- N33 Resina silver
- N34 Resina grigio cenere
- N35 Rovere nodato caramel
- N36 Olmo moka

### LACCATO / LAQUÉ / LACQUERED

Poro aperto  
/ Pores ouverts / Open pore

- L31 Bianco luce
- L32 Bianco panna
- L33 Bianco vela
- L34 Grigio corda
- L35 Grigio canapa
- L39 Rosso aragosta
- L40 Tortora

### EFFETTO MALTA / EFFET-BÉTON / MORTAR-LOOK

- E01 Corten black
- E02 Corten gold
- E03 Corten silver
- E04 Metalli vissuti nichel
- E05 Metalli vissuti rame
- E06 Beton tortora
- E07 Beton nero
- E08 Beton grigio scuro
- E09 Beton grigio chiaro
- E10 Pietra spatolata tortora
- E11 Pietra spatolata notte
- E12 Pietra spatolata cenere
- E13 Pietra spatolata perla
- E14 Pietra spatolata antracite
- E15 Pietra spatolata travertino
- E17 Pietra spatolata ardesia alluminio
- E19 Bianco assoluto

### ROVERE IMPIALLACCIATO / PLACAGE CHÊNE / OAK VENEER

- W01 Rovere naturale
- W02 Rovere grigio
- W03 Rovere tabacco
- W04 Rovere nodato
- W06 Rovere juta
- W07 Rovere fumé

**Consolle estensibile, struttura in metallo, meccanismo telescopico in alluminio, piano in nobilitato, laccato, legno o effetto malta, 3 o 5 allunghe. Gambe centrali di supporto. Ganci reggi allunghe retrattili.**

Console extensible, structure en métal, mécanique télescopique en aluminium, plateau mélamine, laqué, bois ou effet-béton, 3 ou 5 rallonges. Pieds centraux de support. Crochets soutient-rallonges rétractables.

Metal frame extending console-table, aluminium telescopic mechanism, top in melamine, lacquered, wood or mortar-look, 3 or 5 extensions. Central supporting legs. Extensions supporting retracting hooks.

## FINITURE BASE FINITIONS PIÉTEMENT BASE FINISHES

### METALLO / MÉTAUX / METALS

- M02 Verniciato grisou goffrato
- M03 Verniciato bianco opaco
- M04 Verniciato nero opaco
- M11 Verniciato grafite goffrato
- M12 Verniciato tortora opaco
- M19 Verniciato bronzo goffrato

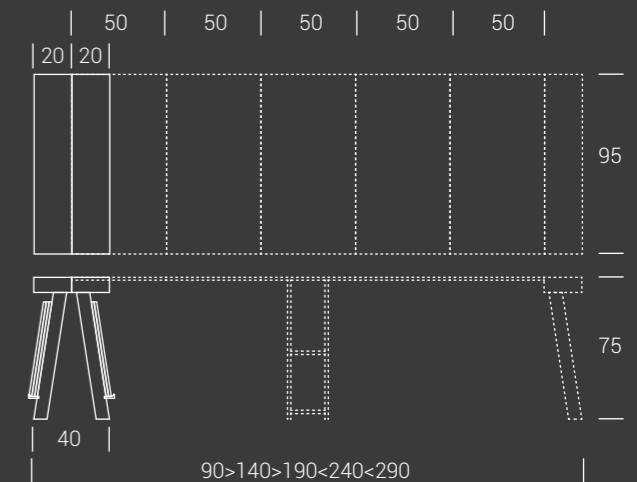
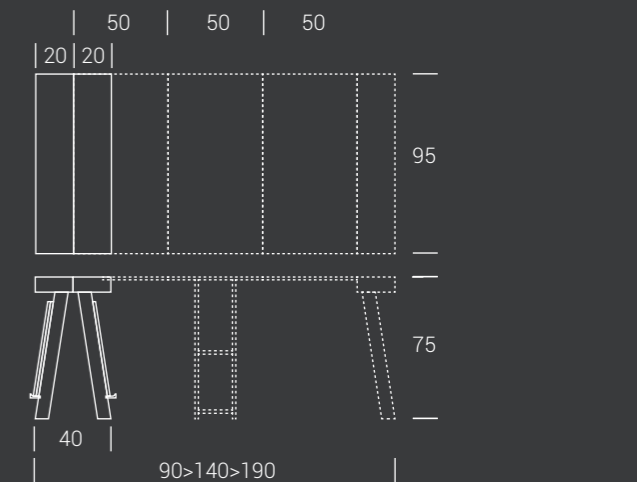

## TREK

TREK SI PRESENTA COME UN OGGETTO D'ARREDO STRAORDINARIO. LA SUA VERSATILITÀ È TALE DA TRASFORMARSI DA CONSOLLE SALVASPAZIO AD AMPIO TAVOLO DA PRANZO: CIÒ È POSSIBILE GRAZIE ALL'INGEGNOSO SISTEMA DI ALLUNGHE COLLOCATO ALL'INTERNO DEL PIANO, VESTITO IN NOBILITATO CEMENTO PER "L'OCCASIONE".

Trek se présente comme un objet d'ameublement extraordinaire. Sa versatilité est de nature à se transformer de simple console en une grande table de repas: cela est possible grâce à l'astucieux système d'extension intégré à l'intérieur du plateau habillé, pour l'occasion, en mélamine finition béton.

Trek is showing-up as an extraordinary home furnishing. Its versatility is such as to be turned from a wall console to a large dining table: this is possible thanks to a clever extending mechanism integrated into the top, dressed, for the occasion, with a melamine top in concrete finish.



26

**TREK**  
design Altacom

**Base/Piédement/Base:** verniciato bianco opaco M03  
**Piano/Plateau/Top:** nobilitato cemento N23



TREK SI PREPARA AD ACCOGLIERE OSPITI INATTESI CON SEMPLICITÀ: IL RISULTATO ESTETICO È PERFETTO, LA SOLIDITÀ NELLA LUNGHEZZA DI TRE METRI È GARANTITA DALLA STRUTTURA METALLICA EXTENSO, COLLOCATA AL CENTRO DEL PIANO PER RAFFORZARE LA STABILITÀ.

Trek se prépare à accueillir les invités inattendus avec simplicité: le résultat esthétique est parfait, la solidité en longueur, une fois ouverte, est garantie par la structure en métal extenso, située au milieu du plateau pour en renforcer la stabilité.

Trek gets ready to welcome unexpected guests with simplicity: the aesthetic result is perfect, the solidity in length, once open, is guaranteed by the metal structure extenso, located in the middle of the top to enhance stability.



# TREK & EXTENSO



## FINITURE PIANO FINITIONS PLATEAU TOP FINISHES

### NOBILITATO / MÉLAMINE / MELAMINE

- N05 Bianco matrix
- N20 Natural halifax oak
- N21 Pino jackson
- N23 Cemento
- N24 Ardesia
- N25 Vintage chiaro
- N30 Morera
- N33 Resina silver
- N34 Resina grigio cenere
- N35 Rovere nodato caramel
- N36 Olmo moka

### LACCATO / LAQUÉ / LACQUERED

**Poro aperto**  
/ Pores ouverts / Open pore

**Opaco**  
/ Mat / Matt

**Lucido**  
/ Brilliant / High gloss

- |     |     |     |                |
|-----|-----|-----|----------------|
| L31 | L51 | L01 | Bianco luce    |
| L32 | L52 |     | Bianco panna   |
| L33 | L53 |     | Bianco vela    |
| L34 | L54 |     | Grigio corda   |
| L35 | L55 |     | Grigio canapa  |
| L39 | L59 |     | Rosso aragosta |
| L40 | L60 |     | Tortora        |

### EFFETTO MALTA / EFFET-BÉTON / MORTAR-LOOK

- E01 Corten black
- E02 Corten gold
- E03 Corten silver
- E04 Metalli vissuti nichel
- E05 Metalli vissuti rame
- E06 Beton tortora
- E07 Beton nero
- E08 Beton grigio scuro
- E09 Beton grigio chiaro
- E10 Pietra spatolata tortora
- E11 Pietra spatolata notte
- E12 Pietra spatolata cenere
- E13 Pietra spatolata perla
- E14 Pietra spatolata antracite
- E15 Pietra spatolata travertino
- E17 Pietra spatolata ardesia alluminio
- E19 Bianco assoluto

### ROVERE IMPIALLACCIATO / PLACAGE CHÊNE / OAK VENEER

- W01 Rovere naturale
- W02 Rovere grigio
- W03 Rovere tabacco
- W04 Rovere nodato
- W06 Rovere juta
- W07 Rovere fumé

**Consolle estensibile, struttura in metallo, meccanismo telescopico in alluminio, piano in nobilitato, laccato, legno o effetto malta, 3 o 5 allunghe. Gambe centrali di supporto o porta allunghe opzionale Extenso.**

Console extensible, structure en métal, mécanique télescopique en aluminium, plateau mélamine, laqué, bois ou effet-béton, 3 ou 5 rallonges. Pieds centraux de support ou rack à rallonges optionnel Extenso.

Metal frame extending console-table, aluminium telescopic mechanism, top in melamine, lacquered, wood or mortar-look, 3 or 5 extensions. Central supporting legs or optional extensions holder Extenso.

## FINITURE BASE FINITIONS PIÉTEMENT BASE FINISHES

### METALLO / MÉTAUX / METALS

- M02 Verniciato grisou goffrato
- M03 Verniciato bianco opaco
- M04 Verniciato nero opaco
- M05 Cromo lucido
- M11 Verniciato grafite goffrato
- M12 Verniciato tortora opaco
- M19 Verniciato bronzo goffrato

### EXTENSO OPTIONAL

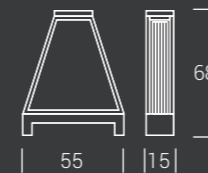

**Struttura metallica girevole porta allunghe per consolle: Combi, Lobby, Quad e Trek.**

Structure métallique pivotante porte-rallonges pour les consoles: Combi, Lobby, Quad, Trek.

Swivel metal frame, extensions holder for consoles: Combi, Lobby, Quad, Trek.

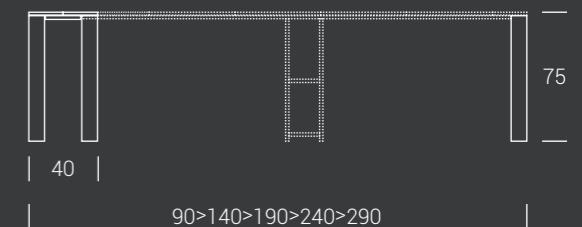
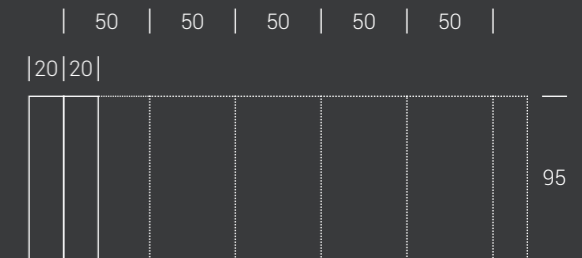
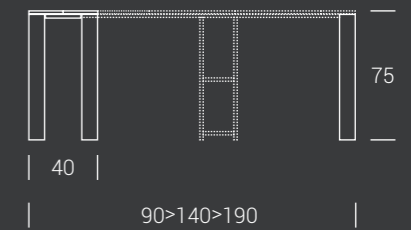
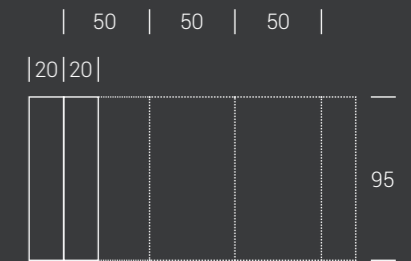



## Q U A D

IL TAVOLO IN ASSOLUTO PIÙ VERSATILE E SALVASPAZIO, NON È UN TAVOLO, MA UNA CONSOLLE! QUAD PUÒ ESSERE POSIZIONATA OVUNQUE GRAZIE ALLA SUA LIMITATA PROFONDITÀ (APPENA 40 CM), MA NELLA VERSIONE ALLUNGATA OSPITA COMODAMENTE FINO A 12 PERSONE. PROPRIO QUELLO CHE CI VUOLE PER ARREDARE SOGGIORNO E SALA DA PRANZO SFRUTTANDO DUE MOBILI IN UNO.

La plus versatile pièce des produits "gain de place" n'est pas une table, mais une console! Quad peut être placée partout grâce à sa petite profondeur de seulement 40 cm, mais en position ouverte, elle permet d'accueillir jusqu'à 12 personnes confortablement. Juste ce qu'il faut pour décorer en même temps le salon et la salle à manger.

The most versatile and space-saving solution is not a table but a console! Quad can be placed everywhere thanks to its limited width (just 40 cm), but in its extended version can host up to 12 people. This is exactly what is needed to furnish a living room and dining room exploiting two solutions in one.



27

**QUAD**  
design Altacom

**Base/Piédement/Base:** verniciato bronzo goffrato M19  
**Piano/Plateau/Top:** rovere grigio W02

QUAD



QUAD



27  
QUAD  
design Altacom

## QUAD & EXTENSO



### FINITURE PIANO FINITIONS PLATEAU TOP FINISHES

#### NOBILITATO / MÉLAMINE / MELAMINE

N05	Bianco matrix
N20	Natural halifax oak
N21	Pino jackson
N23	Cemento
N24	Ardesia
N25	Vintage chiaro
N30	Morera
N33	Resina silver
N34	Resina grigio cenere
N35	Rovere nodato caramel
N36	Olmo moka

#### LACCATO / LAQUÉ / LACQUERED

Poroso aperto  
/ Pores ouverts / Open pore

Opaco  
/ Mat / Matt

Lucido  
/ Brilliant / High gloss

L31	L51	L01	Bianco luce
L32	L52		Bianco panna
L33	L53		Bianco vela
L34	L54		Grigio corda
L35	L55		Grigio canapa
L39	L59		Rosso aragosta
L40	L60		Tortora

#### EFFETTO MALTA / EFFET-BÉTON / MORTAR-LOOK

E01	Corten black
E02	Corten gold
E03	Corten silver
E04	Metalli vissuti nichel
E05	Metalli vissuti rame
E06	Beton tortora
E07	Beton nero
E08	Beton grigio scuro
E09	Beton grigio chiaro
E10	Pietra spatolata tortora
E11	Pietra spatolata notte
E12	Pietra spatolata cenere
E13	Pietra spatolata perla
E14	Pietra spatolata antracite
E15	Pietra spatolata travertino
E17	Pietra spatolata ardesia alluminio
E19	Bianco assoluto

#### ROVERE IMPIALLACCIATO / PLACAGE CHÊNE / OAK VENEER

W01	Rovere naturale
W02	Rovere grigio
W03	Rovere tabacco
W04	Rovere nodato
W06	Rovere juta
W07	Rovere fumé

Consolle estensibile, struttura in metallo, meccanismo telescopico in alluminio, piano in nobilitato, laccato, legno o effetto malta, 3 o 5 allunghe. Gambe centrali di supporto o porta allunghe opzionale Extenso.

Console extensible, structure en métal, mécanique télescopique en aluminium, plateau mélamine, laqué, bois ou effet-béton, 3 ou 5 rallonges. Pieds centraux de support ou rack à rallonges optionnel Extenso.

Metal frame extending console-table. Aluminum telescopic mechanism, melamine, lacquered, stained wood or mortar-look top, 3 or 5 extensions. Central supporting legs or optional extensions holder Extenso.

### FINITURE BASE FINITIONS PIÉTEMENT BASE FINISHES

#### METALLO / MÉTAUX / METALS

M02	Verniciato grisou goffrato
M03	Verniciato bianco opaco
M04	Verniciato nero opaco
M05	Cromo lucido
M11	Verniciato grafite goffrato
M12	Verniciato tortora opaco
M19	Verniciato bronzo goffrato

#### EXTENSO OPTIONAL

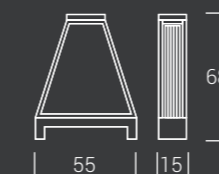

Struttura metallica girevole porta allunghe per consolle: Combi, Lobby, Quad e Trek.

Structure métallique pivotante porte-rallonges pour les consoles: Combi, Lobby, Quad, Trek.

Swivel metal frame, extensions holder for consoles: Combi, Lobby, Quad, Trek.

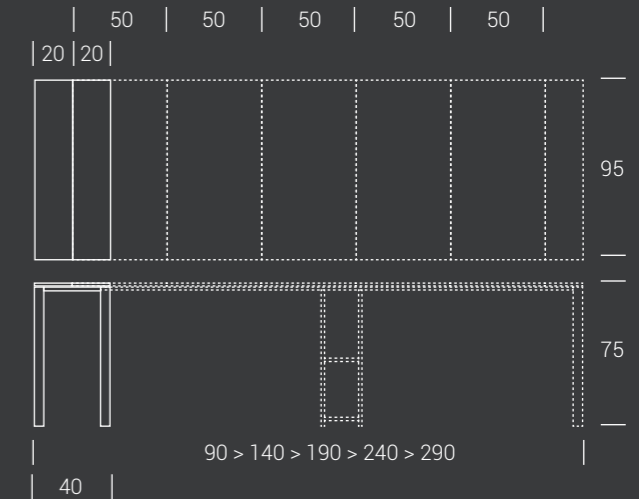
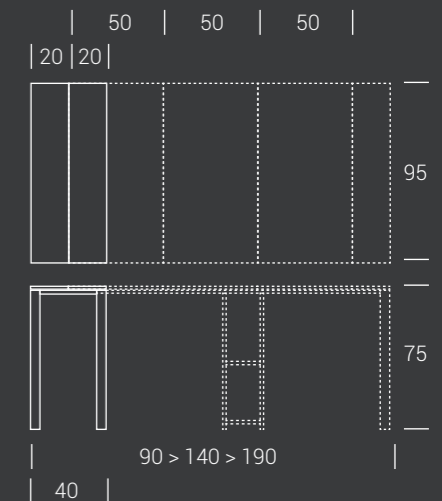

## LOBBY

FORME SEMPLICI E LINEARI CARATTERIZZANO LA CONSOLLE LOBBY, CHE ACCANTO A UNO SPIRITO MINIMAL ASSOCIA UNA GRANDISSIMA FUNZIONALITÀ. POCHI CENTIMETRI DI PROFONDITÀ CHE SI ESPANDONO CON DISINVOLTURA DIVENTANDO UN TAVOLO DA PRANZO PER 12 PERSONE, PER STUPIRE CON ESTREMA SEMPLICITÀ.

Les formes simples et linéaires sont les caractéristiques de la console Lobby, parfaite symbiose entre esprit minimal et grande fonctionnalité. Sa petite profondeur s'étend avec aisance, permettant d'accueillir à table jusqu'à 12 personnes, en étonnant avec une grande simplicité.

Simple and linear shapes together with a minimalist soul are the characteristics of the Lobby console. Notwithstanding its minimalism, it is provided with a great functionality. A few centimeters width shapes into a 12 people dining table. Its extreme ease is astonishing.

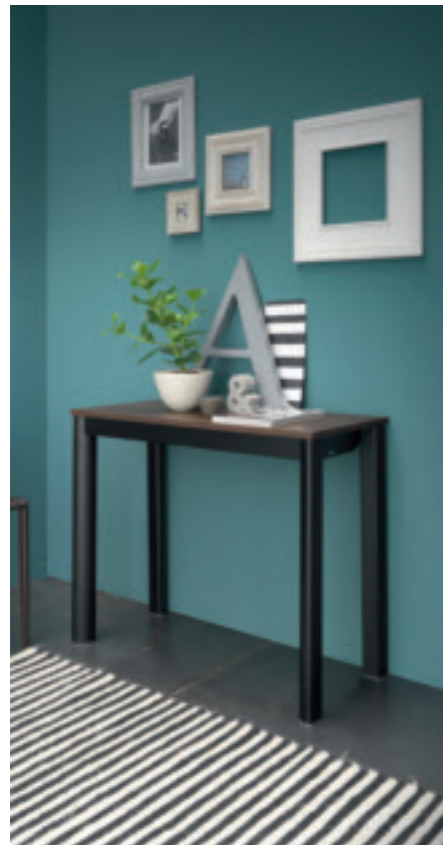

28

**LOBBY**  
design Altacom

**Base/Piédement/Base:** verniciato nero M04  
**Piano/Plateau/Top:** nobilitato olmo moka N36



LOBBY



# LOBBY & EXTENSO

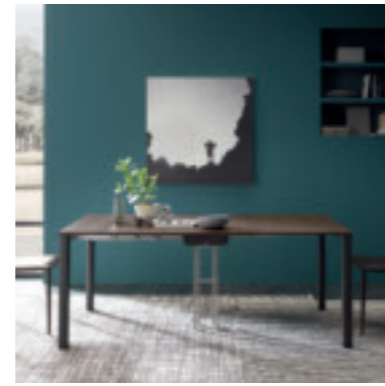
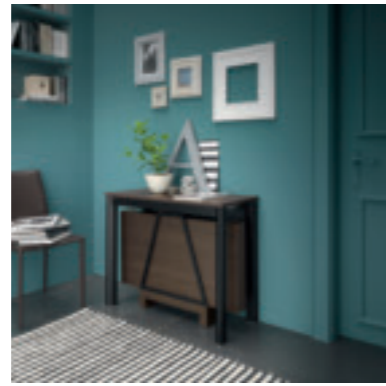

## FINITURE PIANO FINITIONS PLATEAU TOP FINISHES

### NOBILITATO / MÉLAMINE / MELAMINE

- N05 Bianco matrix
- N20 Natural halifax oak
- N21 Pino jackson
- N23 Cemento
- N24 Ardesia
- N25 Vintage chiaro
- N30 Morera
- N33 Resina silver
- N34 Resina grigio cenere
- N35 Rovere nodato caramel
- N36 Olmo moka

### LACCATO / LAQUÉ / LACQUERED

Poro aperto  
/ Pores ouverts / Open pore

Opaco  
/ Mat / Matt

Lucido  
/ Brilliant / High gloss

- |     |     |     |                |
|-----|-----|-----|----------------|
| L31 | L51 | L01 | Bianco luce    |
| L32 | L52 |     | Bianco panna   |
| L33 | L53 |     | Bianco vela    |
| L34 | L54 |     | Grigio corda   |
| L35 | L55 |     | Grigio canapa  |
| L39 | L59 |     | Rosso aragosta |
| L40 | L60 |     | Tortora        |

### EFFETTO MALTA / EFFET-BÉTON / MORTAR-LOOK

- E01 Corten black
- E02 Corten gold
- E03 Corten silver
- E04 Metalli vissuti nichel
- E05 Metalli vissuti rame
- E06 Beton tortora
- E07 Beton nero
- E08 Beton grigio scuro
- E09 Beton grigio chiaro
- E10 Pietra spatolata tortora
- E11 Pietra spatolata notte
- E12 Pietra spatolata cenere
- E13 Pietra spatolata perla
- E14 Pietra spatolata antracite
- E15 Pietra spatolata travertino
- E17 Pietra spatolata ardesia alluminio
- E19 Bianco assoluto

### ROVERE IMPIALLACCIATO / PLACAGE CHÊNE / OAK VENEER

- W01 Rovere naturale
- W02 Rovere grigio
- W03 Rovere tabacco
- W04 Rovere nodato
- W06 Rovere juta
- W07 Rovere fumé

Consolle estensibile, struttura in metallo, meccanismo telescopico in alluminio, piano in nobilitato, laccato, legno o effetto malta, 3 o 5 allunghe. Gambe centrali di supporto o porta allunghe opzionale Extenso.

Console extensible, structure en métal, mécanique télescopique en aluminium, plateau mélamine, laqué, bois ou effet-béton, 3 ou 5 rallonges. Pieds centraux de support ou rack à rallonges optionnel Extenso.

Metal frame extending console-table. Aluminum telescopic mechanism, melamine, lacquered, stained wood or mortar-look top, 3 or 5 extensions. Central supporting legs or optional extensions holder Extenso.

## FINITURE BASE FINITIONS PIÉTEMENT BASE FINISHES

### METALLO / MÉTAUX / METALS

- M02 Verniciato grisou goffrato
- M03 Verniciato bianco opaco
- M04 Verniciato nero opaco
- M05 Cromo lucido
- M11 Verniciato grafite goffrato
- M12 Verniciato tortora opaco
- M19 Verniciato bronzo goffrato

### EXTENSO OPTIONAL

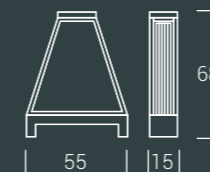

Struttura metallica girevole porta allunghe per consolle: Combi, Lobby, Quad e Trek.

Structure métallique pivotante porte-rallonges pour les consoles: Combi, Lobby, Quad, Trek.

Swivel metal frame, extensions holder for consoles: Combi, Lobby, Quad, Trek.

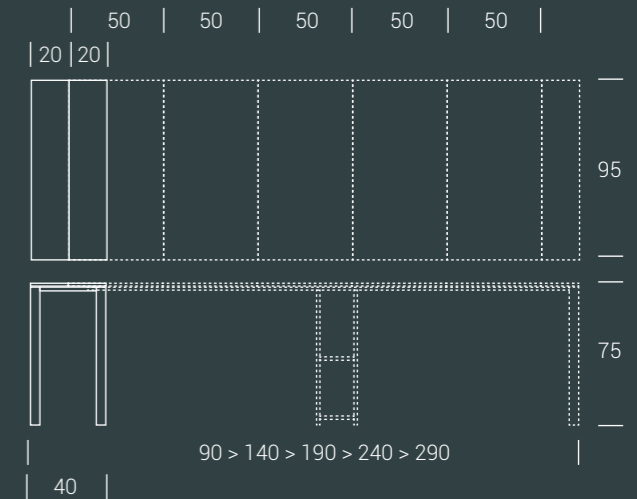
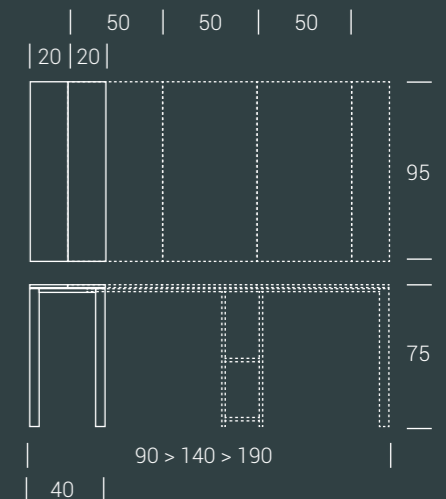



# COMBI

IL RIGORE FORMALE DELLA CONSOLLE COMBI SI TRAFORMA IN RAFFINATA E AMPIA OSPITALITÀ QUANDO APRENDOSI IN TUTTA LA SUA ESTENSIONE ACCOGLIE COMODAMENTE OTTO OSPITI A PRANZO. L'ATTUALITÀ DI COMBI È RAPPRESENTATA DALLA CONTINUITÀ DEL MATERIALE CHE COINVOLGE PIANO E STRUTTURA ADEGUANDOSI ALL'AMBIENTE IN TOTALE ARMONIA.

La rigueur formelle de la console Combi se transforme en élégante hospitalité, lorsque, en s'ouvrant complètement, elle accueille jusqu'à 8 personnes très à l'aise. L'actualité de Combi réside dans la continuité de la matière de son plateau et de sa structure, en s'adaptant à l'environnement en parfaite harmonie.

The formal accuracy of the console Combi transforms in refined and broad hospitality as when you open it at its maximum extensions, it can comfortably host up to eight people. The newness of this console is represented by the continuity of the material, which involves top and structure adapting to the surrounding space in complete harmony.



29

**COMBI**  
design Altacom

Base/Piédement/Base: nobilitato cemento N23  
Piano/Plateau/Top: nobilitato cemento N23





# COMBI & EXTENSO



## FINITURE FINITIONS FINISHES

### NOBILITATO / MÉLAMINE / MELAMINE

N05	Bianco matrix
N20	Natural halifax oak
N21	Pino jackson
N23	Cemento
N24	Ardesia
N25	Vintage chiaro
N30	Morera
N33	Resina silver
N34	Resina grigio cenere
N35	Rovere nodato caramel
N36	Olmo moka

**Consolle estensibile in nobilitato,  
meccanismo telescopico in  
alluminio, 3 o 5 allunghe.  
Gambe centrali di supporto  
o porta allunghe opzionale  
Extenso.**

Console extensible en mélamine,  
mécanisme télescopique en aluminium,  
3 ou 5 rallonges. Pieds centraux de  
support ou rack à rallonges optionnel  
Extenso.

Melamine frame extending  
console-table, aluminum telescopic  
mechanism, 3 or 5 extensions.  
Central supporting legs or optional  
extensions holder Extenso.

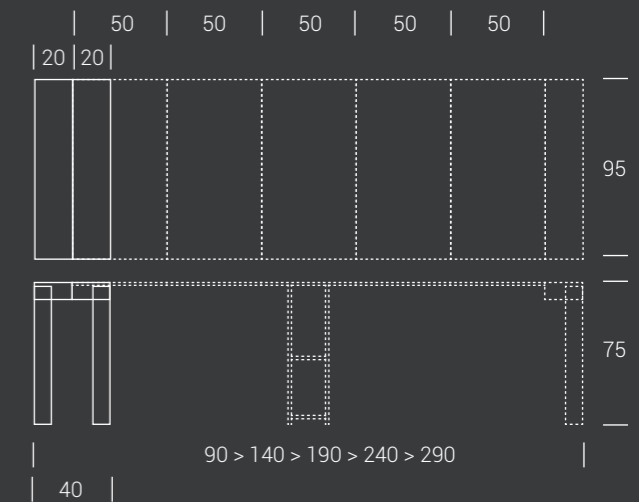
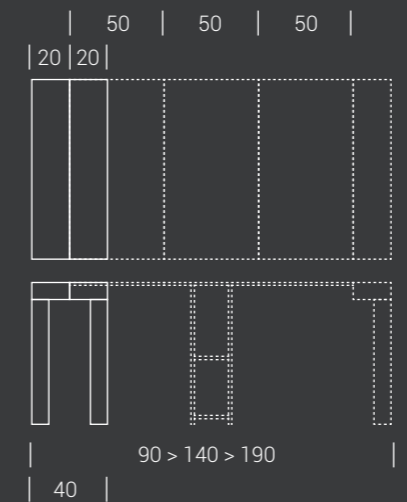

### EXTENSO OPTIONAL

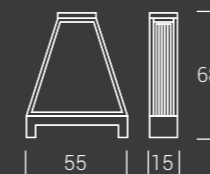

**Struttura metallica girevole  
porta allunghe per consolle:  
Combi, Lobby, Quad e Trek.**

Structure métallique pivotante  
porte-rallonges pour les consoles:  
Combi, Lobby, Quad, Trek.

Swivel metal frame, extensions  
holder for consoles: Combi, Lobby,  
Quad, Trek.

# S Q U A R E

LA ZONA LIVING ACQUISTA UNA MARCIA IN PIÙ CON SQUARE, LA CONSOLLE DALLA STRUTTURA IMPORTANTE, CHE NON SCOMPARE NELL'AMBIENTE, MA NE È PROTAGONISTA E NON PERDE LA SUA PRESENZA SCENICA NEMMENO QUANDO DIVENTA UN TAVOLO DA PRANZO SOLIDO E FUNZIONALE.

Le salon aura une nouvelle allure grâce à Square, la console avec une structure importante, laquelle ne se cache pas dans le décor. Elle sera la protagoniste de votre maison, même en position ouverte, comme table de repas solide et fonctionnelle, avec son grand charme.

Square is a console with an important structure, that doesn't disappear in the room, indeed it becomes the main character both when closed and when opened.



S Q U A R E



S Q U A R E



# S Q U A R E



**Consolle estensibile in nobilitato, meccanismo telescopico in alluminio, 3 o 5 allunghe. Gambe centrali di supporto.**

Console extensible en mélamine, mécanique télescopique en aluminium, 3 ou 5 rallonges. Pieds centraux de support.

Melamine frame extending console-table, aluminum telescopic mechanism, 3 or 5 extensions. Central supporting legs.

## FINITURE FINITIONS FINISHES

### NOBILITATO / MÉLAMINE / MELAMINE

- N05 Bianco matrix
- N20 Natural halifax oak
- N21 Pino jackson
- N23 Cemento
- N24 Ardesia
- N25 Vintage chiaro
- N30 Morera
- N33 Resina silver
- N34 Resina grigio cenere
- N35 Rovere nodato caramel
- N36 Olmo moka

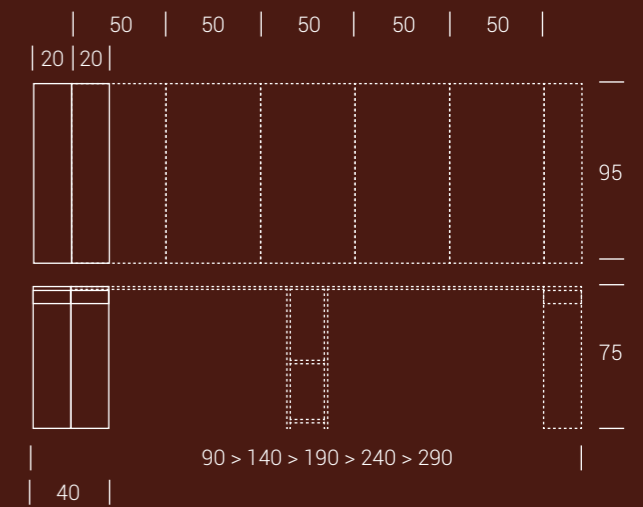
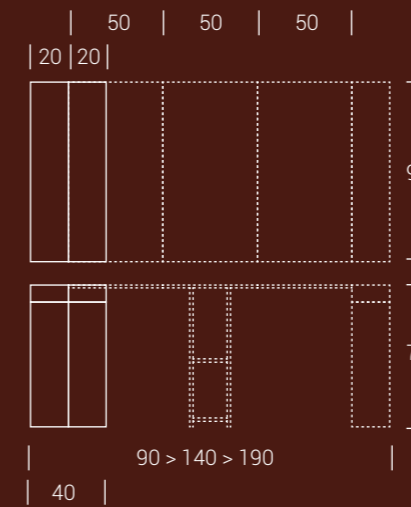



## FLAP

FLAP É L'ESPRESSIONE DELLA MODERNITÀ, SFILA CON UN LOOK "BLACK AND WHITE" MOLTO TRENDY. LA STRUTTURA SI APRE A LIBRO DANDO VITA AD UN ORIGINALE TAVOLO DA PRANZO O TAVOLO STUDIO ADEGUANDOSI PERFETTAMENTE ALLO SPIRITO LIBERO DI CHI CONSIDERA IL "CAMBIAMENTO" UNA COSTANTE.

Flap est le reflet de la modernité, très chic avec son look «black-and-white». Sa structure portefeuille donne vie à une originale table repas et table de travail, en s'adaptant parfaitement à l'esprit libre de ceux qui considèrent le changement une constante.

Flap is the expression of modernity. It appears with a trendy black-and-white look. The structure opens like a book giving life to an original dining table perfectly adapting to the free spirit of those who believe "change" to be a necessity.



31

**FLAP**  
design Altacom

**Base/Piédement/Base:** verniciato grafite gofrato M11  
**Piano/Plateau/Top:** nobilitato resina silver N33



FLAP



# FLAP



**Consolle estensibile, struttura in metallo, piano raddoppiabile a libro in nobilitato o effetto malta.**

Console extensible, structure en métal, plateaux portefeuille en mélamine ou effet-béton.

Metal frame extending console-table, doubling top in melamine or mortar-look.

## FINITURE PIANO FINITIONS PLATEAU TOP FINISHES

### NOBILITATO / MÉLAMINE / MELAMINE

- N05 Bianco matrix
- N20 Natural halifax oak
- N21 Pino jackson
- N23 Cemento
- N24 Ardesia
- N25 Vintage chiaro
- N30 Morera
- N33 Resina silver
- N34 Resina grigio cenere
- N35 Rovere nodato caramel
- N36 Olmo moka

### EFFETTO MALTA / EFFET-BÉTON / MORTAR-LOOK

- E01 Corten black
- E02 Corten gold
- E03 Corten silver
- E04 Metalli vissuti nichel
- E05 Metalli vissuti rame
- E06 Beton tortora
- E07 Beton nero
- E08 Beton grigio scuro
- E09 Beton grigio chiaro
- E10 Pietra spatolata tortora
- E11 Pietra spatolata notte
- E12 Pietra spatolata cenere
- E13 Pietra spatolata perla
- E14 Pietra spatolata antracite
- E15 Pietra spatolata travertino
- E17 Pietra spatolata ardesia alluminio
- E19 Bianco assoluto

## FINITURE BASE FINITIONS PIÉTEMENT BASE FINISHES

### METALLO / MÉTAUX / METALS

- M02 Verniciato grisou goffrato
- M03 Verniciato bianco opaco
- M04 Verniciato nero opaco
- M11 Verniciato grafite goffrato
- M12 Verniciato tortora opaco
- M19 Verniciato bronzo goffrato

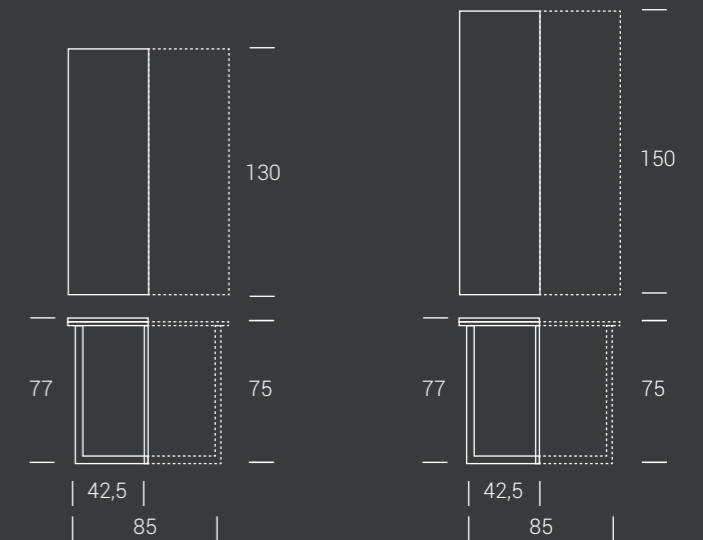

# FAHRENHEIT

FAHRENHEIT SI ESPRIME ATTRAVERSO LA SUA SINGOLARE STRUTTURA AD INTRECCIO IN METALLO, INCONFONDIBILE NEL DESIGN, ESPANDIBILE NELLA SUA VERSIONE ALLUNGATA. IL PIANO AD ALTO SPESSORE È ANCH'ESSO UN ELEMENTO CARATTERIZZANTE COME IN QUESTA VERSIONE IN NOBILITATO ARDESIA, E SI STAGLIA IN CENTRO STANZA COME UN'OPERA SCULTOREA CONTEMPORANEA.

Fahrenheit s' exprime à travers son originale structure à entrelacement de métal, inimitable dans le design, extensible dans sa version étendue. Le plateau de forte épaisseur est également un ingrédient qui la caractérise, comme dans cette version en mélaminé ardoise, et elle se démarque au milieu de la pièce comme une oeuvre de sculpture contemporaine.

Fahrenheit expresses itself through its original structure by a plot of metal, unique in design, expandable in its extended version. The high thickness top is also a characteristic element as in this version in ardesia melamine, and stands out in the middle of the room as a contemporary sculptury work.



32

**FAHRENHEIT**  
design Altacom

**Base/Piètement/Base:** cromo lucido M05  
**Piano/Plateau/Top:** nobilitato ardesia N24







32  
**FAHRENHEIT**  
design Altacom

# FAHRENHEIT



IL PIANO DI FAHRENHEIT IN ROVERE GRIGIO È SAGOMATO NEI BORDI EFFETTO CORTECCIA. LA SUA FORMA EVOCA UNA SEZIONE DI ALBERO ANTICO CHE, POSTO ALL'INTERNO DELLO SPAZIO ABITATIVO, LO INFLUENZA COME ELEMENTO "VIVO".

Le plateau de fahrenheit en chêne gris est conformé avec les chants en effet-écorce. Sa forme évoque la section d'un arbre ancien qui, placé à l'intérieur de l'espace habitant, l'influence comme un élément « vivant ».

The gray oak fahrenheit top is shaped as bark-edge. Its shape evokes the section of an antique tree that, placed into the living space, influences it as an "alive" element.

32

**FAHRENHEIT**  
design Altacom

Base/Piédement/Base: cromo lucido M05  
Piano/Plateau/Top: rovere grigio W02







# F A H R E N H E I T

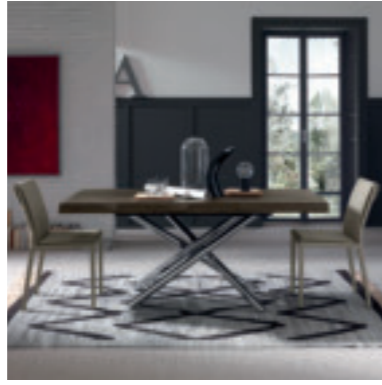

## FINITURE PIANO FINITIONS PLATEAU TOP FINISHES

### NOBILITATO / MÉLAMINE / MELAMINE

- N05 Bianco matrix
- N20 Natural halifax oak
- N21 Pino jackson
- N23 Cemento
- N24 Ardesia
- N25 Vintage chiaro
- N30 Morera
- N33 Resina silver
- N34 Resina grigio cenere
- N35 Rovere nodato caramel
- N36 Olmo moka

### LACCATO / LAQUÉ / LACQUERED

Poro aperto  
/ Pores ouverts / Open pore

- L31 Bianco luce
- L32 Bianco panna
- L33 Bianco vela
- L34 Grigio corda
- L35 Grigio canapa
- L39 Rosso aragosta
- L40 Tortora

### ROVERE IMPIALLACCIATO / PLACAGE CHÊNE / OAK VENEER

- W01 Rovere naturale
- W02 Rovere grigio
- W03 Rovere tabacco
- W04 Rovere nodato
- W06 Rovere juta
- W07 Rovere fumé

### EFFETTO MALTA / EFFET-BÉTON / MORTAR-LOOK

- E01 Corten black
- E02 Corten gold
- E03 Corten silver
- E04 Metalli vissuti nichel
- E05 Metalli vissuti rame
- E06 Beton tortora
- E07 Beton nero
- E08 Beton grigio scuro
- E09 Beton grigio chiaro
- E10 Pietra spatolata tortora
- E11 Pietra spatolata notte
- E12 Pietra spatolata cenere
- E13 Pietra spatolata perla
- E14 Pietra spatolata antracite
- E15 Pietra spatolata travertino
- E17 Pietra spatolata ardesia alluminio
- E19 Bianco assoluto

**Tavolo da pranzo fisso, struttura in metallo, piano in nobilitato, legno bordo corteccia o effetto malta.**

Table de repas fixe, structure en métal, plateau mélamine, bois chants écorce ou effet-béton.

Fixed dining table with metal frame, top in melamine, wood with bark edges or mortar-look.

**Tavolo da pranzo allungabile, struttura in metallo, piano in nobilitato, legno bordo corteccia, o effetto malta, 2 prolunghe interne.**

Table de repas extensible avec 2 rallonges intégrées, structure en métal, plateau mélamine, bois chants écorce ou effet-béton.

Metal frame extending dining table, top in melamine, wood with bark edges or mortar-look, 2 inside extensions.

## FINITURE BASE FINITIONS PIÉTEMENT BASE FINISHES

### METALLO / MÉTAUX / METALS

- M02 Verniciato grisou goffrato
- M03 Verniciato bianco opaco
- M04 Verniciato nero opaco
- M05 Cromo lucido
- M11 Verniciato grafite goffrato
- M12 Verniciato tortora opaco
- M19 Verniciato bronzo goffrato

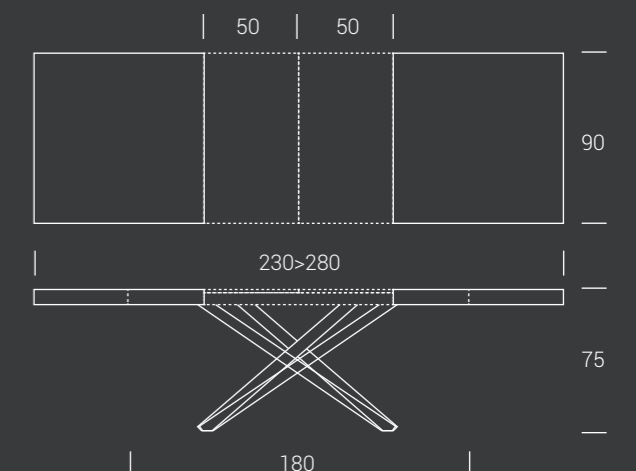
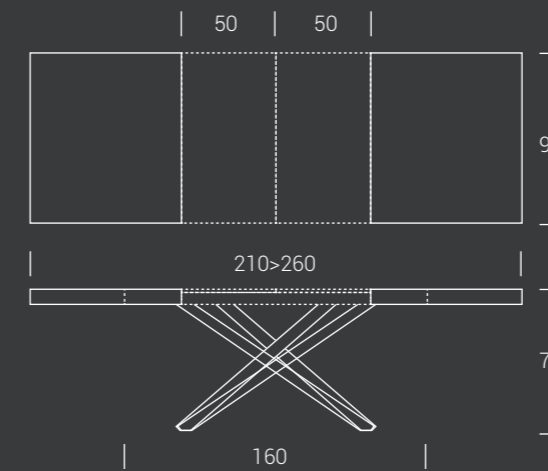
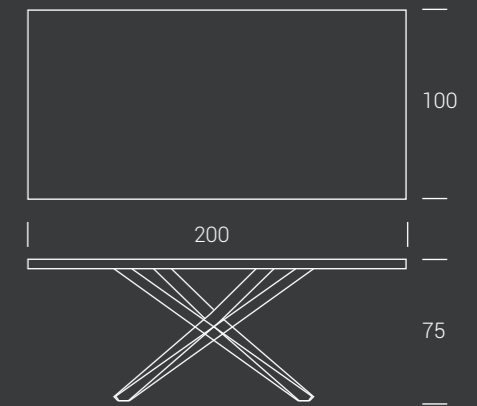
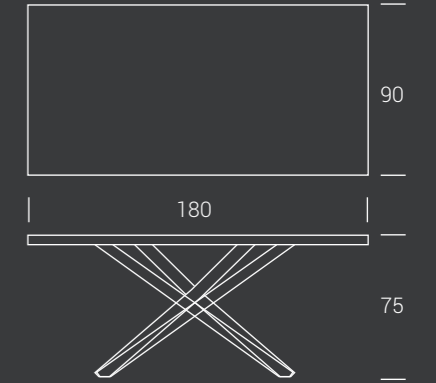

# FAHRENHEIT ROUND

CON IL SUO PIANO ROTONDO SOSTENUTO DA BASE INTRECCIATA IN METALLO, FAHRENHEIT ROUND EVOCA L'ANTICO GIOCO DI SHANGAI NEL QUALE L'UNICA MOSSA SI EPRIME NEL MOVIMENTO DEL PIANO CHE DILATA LA SUA FORMA ATTRAVERSO LA PROLUNGA INTERNA A LIBRO PER DEDICARSI ALLA CONVIVIALITÀ IN TUTTA LA SUA ESUBERANZA. FAHRENHEIT ROUND, UN GIOCO DI STILE FIRMATO ALTACOM.

Avec son plateau rond et son piétement tressé en métal, Fahrenheit Round évoque l'ancien jeu Shanghai, dans lequel le seul truc est le mouvement du plateau et de sa rallonge portefeuille. Fahrenheit Round, un jeu de style signé par Altacom.

With its round top and intertwined metal base, Fahrenheit Round evokes the ancient game of Shanghai, in which the only possible move is expressed through the movement of the top and its book extension. Fahrenheit Round, a classy game signed Altacom.



33

**FAHRENHEIT ROUND**  
design Altacom

**Base/Piétement/Base:** verniciato nero opaco M04  
**Piano/Plateau/Top:** rovere nodato W04

FAHRENHEIT ROUND



# FAHRENHEIT ROUND



## FINITURE PIANO FINITIONS PLATEAU TOP FINISHES

### NOBILITATO / MÉLAMINE / MELAMINE

N05	Bianco matrix
N20	Natural halifax oak
N21	Pino jackson
N23	Cemento
N24	Ardesia
N25	Vintage chiaro
N30	Morera
N33	Resina silver
N34	Resina grigio cenere
N35	Rovere nodato caramel
N36	Olmo moka

### LACCATO / LAQUÉ / LACQUERED

Poro aperto  
/ Pores ouverts / Open pore

L31	Bianco luce
L32	Bianco panna
L33	Bianco vela
L34	Grigio corda
L35	Grigio canapa
L39	Rosso aragosta
L40	Tortora

### ROVERE IMPIALLACCIATO / PLACAGE CHÊNE / OAK VENEER

W01	Rovere naturale
W02	Rovere grigio
W03	Rovere tabacco
W04	Rovere nodato
W06	Rovere juta
W07	Rovere fumé

### VETRO / VERRE / GLASS

G01	Bianco
G02	Tortora
G03	Nero
G04	Bianco acidato
G05	Tortora acidato
G06	Nero acidato

### EFFETTO MALTA / EFFET-BÉTON / MORTAR-LOOK

E01	Corten black
E02	Corten gold
E03	Corten silver
E04	Metalli vissuti nichel
E05	Metalli vissuti rame
E06	Beton tortora
E07	Beton nero
E08	Beton grigio scuro
E09	Beton grigio chiaro
E10	Pietra spatolata tortora
E11	Pietra spatolata notte
E12	Pietra spatolata cenere
E13	Pietra spatolata perla
E14	Pietra spatolata antracite
E15	Pietra spatolata travertino
E17	Pietra spatolata ardesia alluminio
E19	Bianco assoluto

### CERAMICA / CÉRAMIQUE / CERAMIC

K01	Fokos sale
K02	Fokos terra
K03	Fokos piombo
K04	Noir desir lucido
K05	Bianco statuario venato lucido

LAMINAM®

Tavolo da pranzo allungabile,  
base centrale in metallo,  
meccanismo telescopico, piano  
in vetro, legno o effetto malta,  
prolunga interna a libro.

Table de repas avec rallonge intégrée  
porte-feuille, piétement central en  
métal, plateau verre, bois ou effet-béton,  
mécanisme télescopique.

Extending dining table with telescopic  
mechanism, central metal base, top  
in glass, wood or mortar-look, inside  
folded extension.

## FINITURE BASE FINITIONS PIÉTEMENT BASE FINISHES

### METALLO / MÉTAUX / METALS

M02	Verniciato grisou gofrato
M03	Verniciato bianco opaco
M04	Verniciato nero opaco
M11	Verniciato grafite gofrato
M12	Verniciato tortora opaco
M19	Verniciato bronzo gofrato

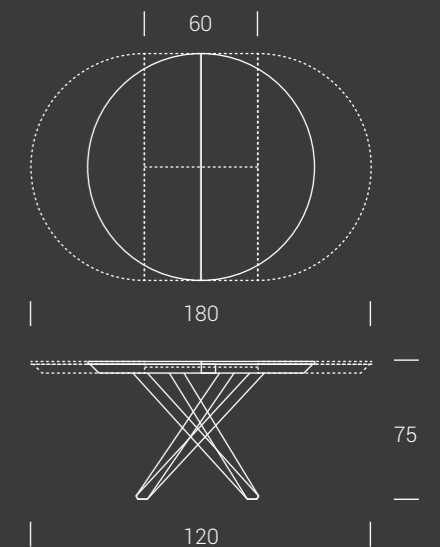

## ARGON

LE GEOMETRIE RIGOROSE DELLA STRUTTURA IN NERO OPACO, SOTTOLINEANO IL CONTRASTO CON IL PIANO EFFETTO PIETRA DI QUESTO TAVOLO, PERFETTAMENTE EQUILIBRATO IN TUTTE LE SUE DIMENSIONI. COLLOCABILE NELL'AREA LIVING COME NELLE PIÙ MODERNE CUCINE ASSOLVE CON RAFFINATEZZA IL PROPRIO COMPITO DI OSPITE, CON GENEROSITÀ.

Les géométries rigoureuses de la structure en noir mat, mettent l'accent sur le contraste avec le plateau en effet-pierre de cette table, parfaitement équilibrée en toutes ses dimensions. Adaptable à tout living ainsi qu'à toute cuisine moderne, elle joue avec classe son rôle d'hôte, généreusement.

The rigorous geometries of the matt black structure emphasize the contrast with the stone-look top of this table, perfectly balanced in all its dimensions. Easygoing in any living area and in the most modern kitchens as well, it plays its host role with generosity.



34

**ARGON**  
design Altacom

**Base/Piètement/Base:** verniciato nero opaco M04  
**Piano/Plateau/Top:** effetto malta pietra spatolata travertino E15

ARGON



34  
**ARGON**  
design Altacom





# ARGON

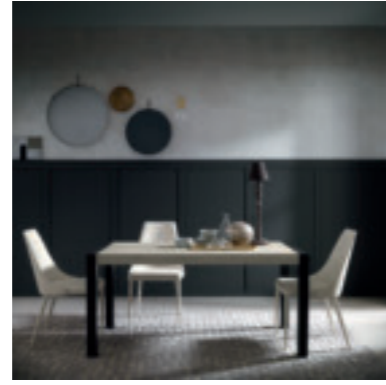

## FINITURE PIANO FINITIONS PLATEAU TOP FINISHES

### NOBILITATO / MÉLAMINE / MELAMINE

- N05 Bianco matrix
- N20 Natural halifax oak
- N21 Pino jackson
- N23 Cemento
- N24 Ardesia
- N25 Vintage chiaro
- N30 Morera
- N33 Resina silver
- N34 Resina grigio cenere
- N35 Rovere nodato caramel
- N36 Olmo moka

### LACCATO / LAQUÉ / LACQUERED

Poro aperto  
/ Pores ouverts / Open pore

- L31 Bianco luce
- L32 Bianco panna
- L33 Bianco vela
- L34 Grigio corda
- L35 Grigio canapa
- L39 Rosso aragosta
- L40 Tortora

### EFFETTO MALTA / EFFET-BÉTON / MORTAR-LOOK

- E01 Corten black
- E02 Corten gold
- E03 Corten silver
- E04 Metalli vissuti nichel
- E05 Metalli vissuti rame
- E06 Beton tortora
- E07 Beton nero
- E08 Beton grigio scuro
- E09 Beton grigio chiaro
- E10 Pietra spatolata tortora
- E11 Pietra spatolata notte
- E12 Pietra spatolata cenere
- E13 Pietra spatolata perla
- E14 Pietra spatolata antracite
- E15 Pietra spatolata travertino
- E17 Pietra spatolata ardesia alluminio
- E19 Bianco assoluto

### ROVERE IMPIALLACCIATO / PLACAGE CHÊNE / OAK VENEER

- W01 Rovere naturale
- W02 Rovere grigio
- W03 Rovere tabacco
- W04 Rovere nodato
- W06 Rovere juta
- W07 Rovere fumé

**Tavolo da pranzo, struttura allungabile in metallo, meccanismo telescopico, piano in nobilitato, legno o effetto malta, 3 prolunghe interne.**

Table de repas avec 3 rallonges intégrées, structure en métal, plateau mélamine, bois ou effet-béton, mécanisme télescopique.

Metal frame dining table with telescopic extending mechanism, top in melamine, wood and mortar-look, 3 inside extensions.

## FINITURE BASE FINITIONS PIÉTEMENT BASE FINISHES

### METALLO / MÉTAUX / METALS

- M02 Verniciato griso gofrato
- M03 Verniciato bianco opaco
- M04 Verniciato nero opaco
- M11 Verniciato grafite gofrato
- M12 Verniciato tortora opaco
- M19 Verniciato bronzo gofrato

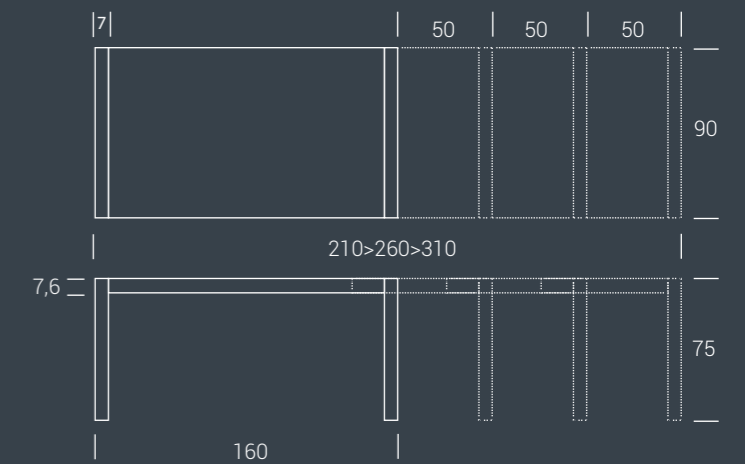
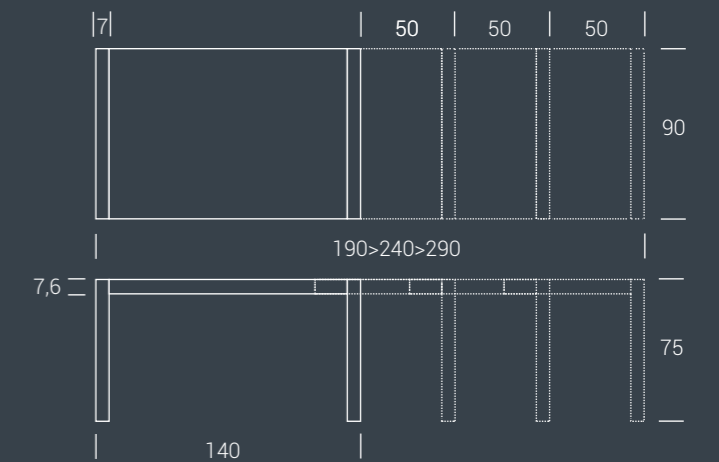

# TEOREMA

LA CARATTERISTICA FORMA TRIANGOLARE DELLE GAMBE UNITA AL PIANO IN VETRO ACIDATO NERO, REGALA UN'IMMAGINE DI ELEGANZA FORMALE CHE BEN SI PRESTA AD ARREDARE CONTESTI CONTEMPORANEI. LA TESI È QUELLA DI AVERE UN PIANO PER LE DIFFERENTI ESIGENZE ABITATIVE, E TEOREMA È LA RISPOSTA CONCRETA ALLA RICERCA DEL BELLO "FUNZIONALE".

La caractéristique forme triangulaire des pieds, ainsi que le plateau en verre dépoli noir, donne une image d'élégance formelle qui se prête bien à aménager des contextes contemporains. L'idée est d'avoir un plateau pour chacune des différentes exigences d'habitat, et teorema est la réponse concrète à la recherche du beau « fonctionnel ».

The characteristic triangular shape of the legs, combined with the black frosted glass top, gives an image of formal elegance that is definitely open to furnish any contemporary context. The goal is to have a top for any different need of the habitat, and teorema is the concrete answer to the search of the "functional" beauty.



**Base/Piédement/Base:** verniciato nero opaco M04  
**Piano/Plateau/Top:** vetro nero acidato G06

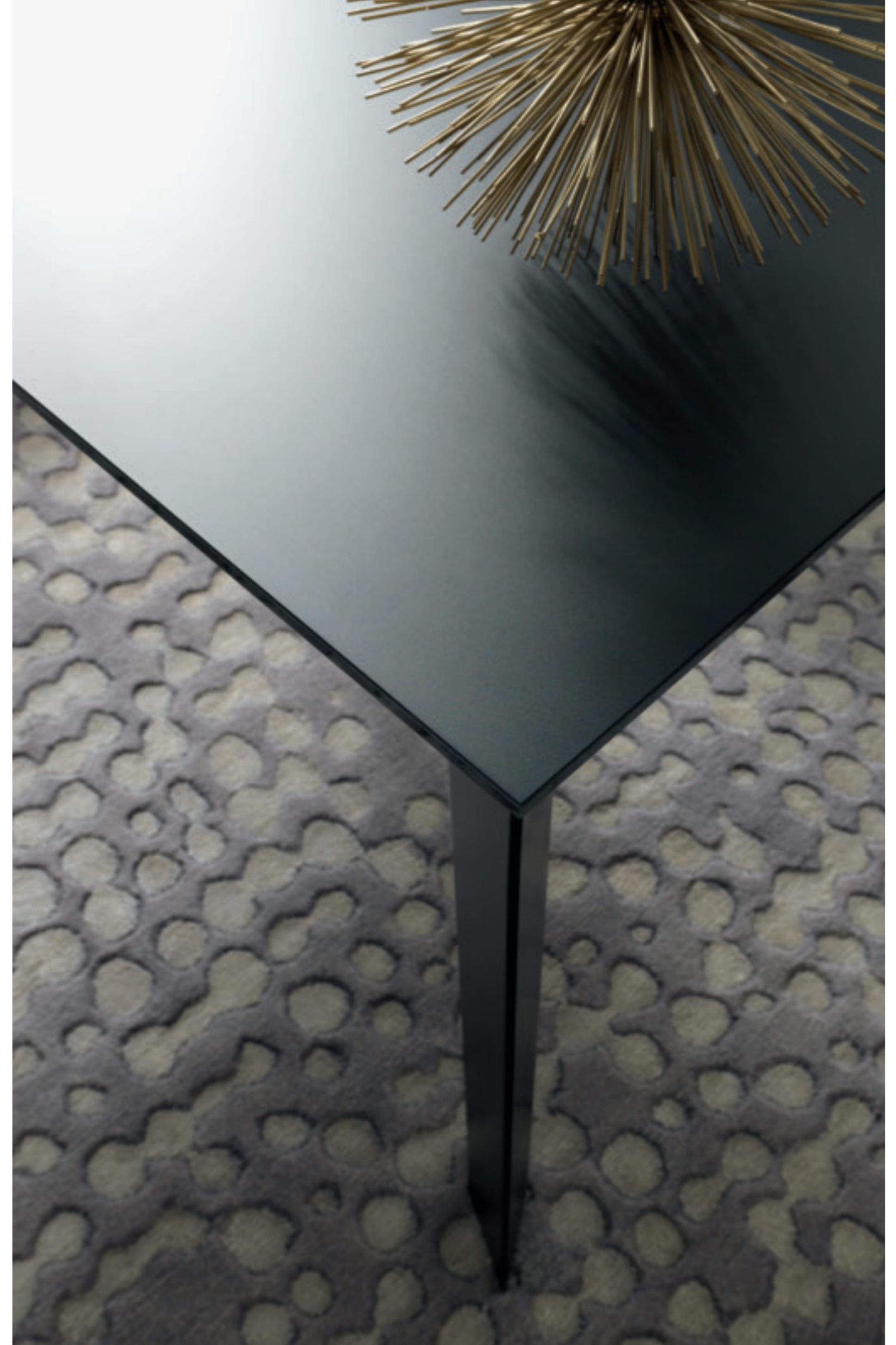



# TEOREMA

TEOREMA SI ARRICCHISCE DI OPPORTUNITÀ PER SEGUIRE LA TENDENZA DELL'ARREDO CONTEMPORANEO NEL QUALE IL MATERIALE DIVENTA PROTAGONISTA INTEGRANDOSI ALLA FORMA E AL DESIGN DELL'OGGETTO. TEOREMA VESTE I SUOI PIANI IN CERAMICA FOKOS PER UN IMPATTO VISIVO E TATTILE DI GRANDE EFFETTO.

Teorema s'enrichit de plein d'opportunités pour suivre la tendance de l'habitat contemporain où le matériel devient le protagoniste, en s'intégrant avec la forme et le design de l'objet. Teorema habille ses plateaux avec de la céramique fokos pour un impact visuel et tactile de grand effet.

Teorema enriches with many opportunities for following the trend of contemporary furnishings in which the material becomes the protagonist, integrating into the shape and the design of the object. Teorema dresses its tops with fokos ceramic for a visual and tactile impact of great effect.



35

**TEOREMA**  
design Altacom

**Base/Piédement/Base:** verniciato nero opaco M04  
**Piano/Plateau/Top:** ceramica fokos piombo K03

# TEOREMA

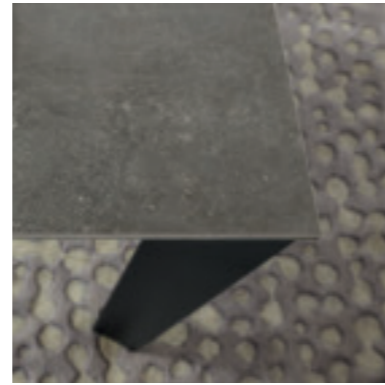
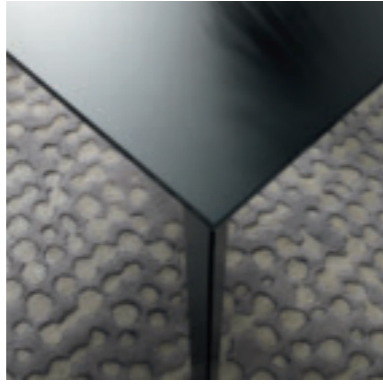

## FINITURE PIANO FINITIONS PLATEAU TOP FINISHES

### NOBILITATO / MÉLAMINE / MELAMINE

- N05 Bianco matrix
- N20 Natural halifax oak
- N21 Pino jackson
- N23 Cemento
- N24 Ardesia
- N25 Vintage chiaro
- N30 Morera
- N33 Resina silver
- N34 Resina grigio cenere
- N35 Rovere nodato caramel
- N36 Olmo moka

### LACCATO / LAQUÉ / LACQUERED

Poros aperto  
/ Pores ouverts / Open pore

- L31 Bianco luce
- L32 Bianco panna
- L33 Bianco vela
- L34 Grigio corda
- L35 Grigio canapa
- L39 Rosso aragosta
- L40 Tortora

### ROVERE IMPIALLACCIATO / PLACAGE CHÊNE / OAK VENEER

- W01 Rovere naturale
- W02 Rovere grigio
- W03 Rovere tabacco
- W04 Rovere nodato
- W06 Rovere juta
- W07 Rovere fumé

### LEGNO MASSICCIO / BOISS MASSIF / SOLID WOOD

- W21 Rovere vecchio massiccio termotrattato
- W32 Rovere vecchio massiccio naturale
- W33 Rovere vecchio massiccio grigio

### CERAMICA / CÉRAMIQUE / CERAMIC

- K01 Fokos sale
- K02 Fokos terra
- K03 Fokos piombo
- K04 Noir desir lucido
- K05 Bianco statuario venato lucido

### VETRO / VERRE / GLASS

- G01 Bianco
- G02 Tortora
- G03 Nero
- G04 Bianco acidato
- G05 Tortora acidato
- G06 Nero acidato

### EFFETTO MALTA / EFFET-BÉTON / MORTAR-LOOK

- E01 Corten black
- E02 Corten gold
- E03 Corten silver
- E04 Metalli vissuti nichel
- E05 Metalli vissuti rame
- E06 Beton tortora
- E07 Beton nero
- E08 Beton grigio scuro
- E09 Beton grigio chiaro
- E10 Pietra spatolata tortora
- E11 Pietra spatolata notte
- E12 Pietra spatolata cenere
- E13 Pietra spatolata perla
- E14 Pietra spatolata antracite
- E15 Pietra spatolata travertino
- E17 Pietra spatolata ardesia alluminio
- E19 Bianco assoluto

LAMINAM®

**Tavolo da pranzo, struttura allungabile in metallo, meccanismo telescopico, piano in nobilitato, legno, effetto malta, vetro o ceramica. Disponibile con meccanismo tradizionale e allunghe a libro o con meccanismo super allungabile con allunghe interne.**

Table de repas, structure en métal, plateau mélamine, verre, bois, laqué, effet-béton ou céramique, mécanisme télescopique. Disponible avec mécanique traditionnelle et rallonges porte-feuille, ou mécanique super-extensible avec rallonges intégrées.

Metal frame dining table with telescopic extending mechanism, top in melamine, glass, stained wood, mortar-look or ceramic. Available with traditional mechanism and book extensions or with super-extensible mechanism and inside extensions.

## FINITURE BASE FINITIONS PIÉTEMENT BASE FINISHES

### METALLO / MÉTAUX / METALS

- M02 Verniciato grisou gofrato
- M03 Verniciato bianco opaco
- M04 Verniciato nero opaco
- M05 Cromo lucido
- M11 Verniciato grafite gofrato
- M12 Verniciato tortora opaco
- M19 Verniciato bronzo gofrato

### TEOREMA SUPER

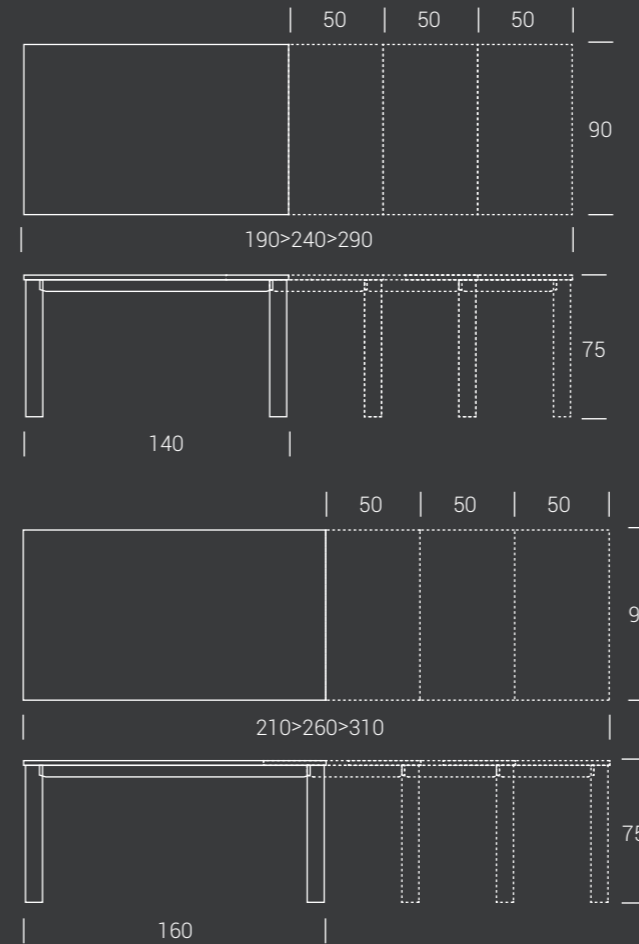

### TEOREMA

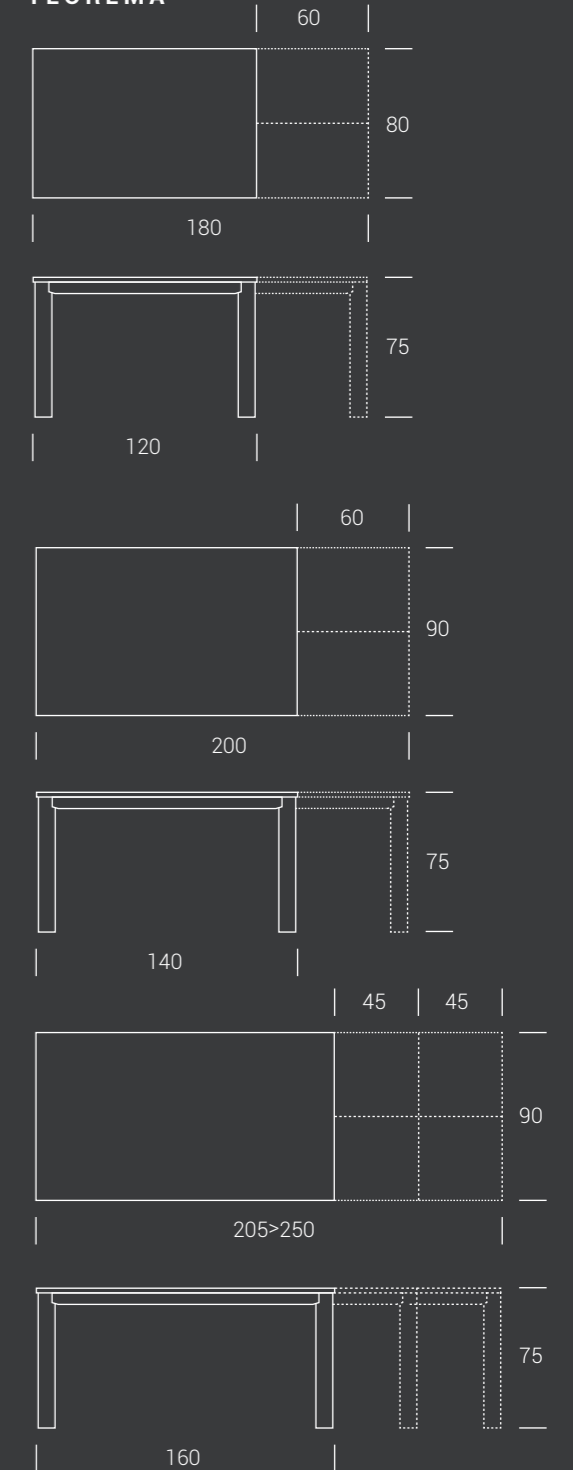

## SUN

SUN, NELLA SUA FORMA A CALICE, EVOCA UNA COPPA DI CHAMPAGNE: IN EFFETTI QUESTO TAVOLO HA TUTTA L'ARIA DI VOLER FESTEGGIARE IL CONNUBIO VINCENTE TRA RAFFINATEZZA E SINUOSITÀ DI UN DESIGN EVOLUTO E LA RICERCATEZZA DEL MATERIALE DEL PIANO IN CERAMICA NOIR DESIR LUCIDO. DOMINA AL CENTRO DELLA SALA, ACCOGLIENTE NELLA SUA ROTONDITÀ, DIVENTA ELLITTICO PER OFFRIRSI NELLE SUE PERFORMACES DIMENSIONALI.

Sun, dans sa forme "tulipe", évoque un verre de champagne: en fait, cette table a l'air de vouloir fêter l'union gagnante entre l'élégance et la sinuosité d'un design avancé et, également, avec le raffinement du matériel du plateau, la céramique noir desir brillant. Dominante au centre de la pièce, accueillante dans sa rondeur, elle devient elliptique pour s'offrir dans ses performances dimensionnelles.

Sun, in its "tulipe" shape, evokes a cup of champagne. In fact this table seems to be ready to celebrate the winning marriage between the sophistication and the sinuosity of an evolved design and the refinement of the material of the top, the shining noir desir ceramic. Dominant in the middle of the room, welcoming in its roundness, it becomes elliptical to offer itself in its dimensional performances.



36

SUN

design Altacom

Base/Piédement/Base: verniciato nero opaco M04  
Piano/Plateau/Top: ceramica noir desir lucido K04









**FINITURE PIANO**  
**FINITIONS PLATEAU**  
**TOP FINISHES**

**NOBILITATO**  
**/ MÉLAMINE**  
**/ MELAMINE**

- N05 Bianco matrix
- N20 Natural halifax oak
- N21 Pino jackson
- N23 Cemento
- N24 Ardesia
- N25 Vintage chiaro
- N30 Morera
- N33 Resina silver
- N34 Resina grigio cenere
- N35 Rovere nodato caramel
- N36 Olmo moka

**LACCATO**  
**/ LAQUÉ**  
**/ LACQUERED**

Poro aperto  
/ Pores ouverts / Open pore

- L31 Bianco luce
- L32 Bianco panna
- L33 Bianco vela
- L34 Grigio corda
- L35 Grigio canapa
- L39 Rosso aragosta
- L40 Tortora

**ROVERE IMPIALLACCIATO**  
**/ PLACAGE CHÊNE**  
**/ OAK VENEER**

- W01 Rovere naturale
- W02 Rovere grigio
- W03 Rovere tabacco
- W04 Rovere nodato
- W06 Rovere juta
- W07 Rovere fumé

**VETRO**  
**/ VERRE**  
**/ GLASS**

- G01 Bianco
- G02 Tortora
- G03 Nero
- G04 Bianco acidato
- G05 Tortora acidato
- G06 Nero acidato

**CERAMICA**  
**/ CÉRAMIQUE**  
**/ CERAMIC**

- K01 Fokos sale
- K02 Fokos terra
- K03 Fokos piombo
- K04 Noir desir lucido
- K05 Bianco statuario venato lucido

**EFFETTO MALTA**  
**/ EFFET-BÉTON**  
**/ MORTAR-LOOK**

- E01 Corten black
- E02 Corten gold
- E03 Corten silver
- E04 Metalli vissuti nichel
- E05 Metalli vissuti rame
- E06 Beton tortora
- E07 Beton nero
- E08 Beton grigio scuro
- E09 Beton grigio chiaro
- E10 Pietra spatolata tortora
- E11 Pietra spatolata notte
- E12 Pietra spatolata cenere
- E13 Pietra spatolata perla
- E14 Pietra spatolata antracite
- E15 Pietra spatolata travertino
- E17 Pietra spatolata ardesia alluminio
- E19 Bianco assoluto

**Tavolo da pranzo allungabile,**  
**base centrale in metallo,**  
**meccanismo telescopico,**  
**piano in vetro, ceramica,**  
**legno o effetto malta,**  
**prolunga interna a libro.**

Table de repas avec rallonge intégrée  
porte-feuille, piétement central en  
métal, plateau verre, céramique,  
bois ou effet-béton, mécanisme  
télescopique.

Extending dining table with telescopic  
mechanism, metal central base, top in  
glass, ceramic, wood or mortar-look,  
inside folded extension.

**FINITURE BASE**  
**FINITIONS PIÉTEMENT**  
**BASE FINISHES**

**METALLO**  
**/ MÉTAUX**  
**/ METALS**

- M02 Verniciato grisou goffrato
- M03 Verniciato bianco opaco
- M04 Verniciato nero opaco
- M11 Verniciato grafite goffrato
- M12 Verniciato tortora opaco
- M19 Verniciato bronzo goffrato

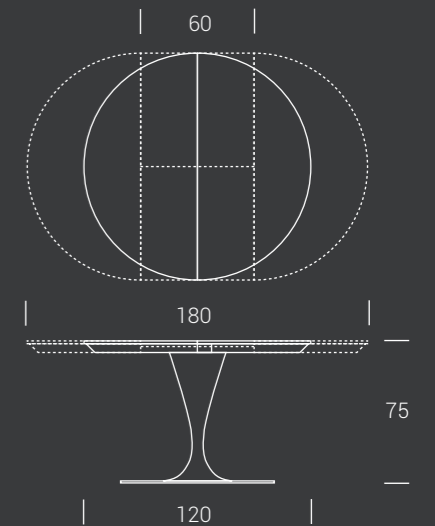

## MERIDIANO

MERIDIANO SI ISPIRA ALLA NATURA CHE PER NULLA INVADENTE ENTRA NELLE NOSTRE CASE CON FORME INGENTILITE DALLA MANO DELL'ARTIGIANO PER RENDERE CONFORTEVOLE E BELLO IL NOSTRO HABITAT. UN PIANO IN ROVERE NODATO CON BORDI EFFETTO CORTECCIA SEMBRA ESSERE SENZA PESO PER EFFETTO DELLA STRUTTURA DI SOSTEGNO IN VETRO TRASPARENTE. MERIDIANO "UNA FORZA DELLA NATURA".

Meridiano s'inspire à la nature qui, pas du tout envahissante, rentre dans nos maisons avec des formes adoucies par la main de l'artisan pour rendre confortable et beau notre habitat. Un plateau en chêne noueux avec les chants en effet-écorce paraît n'avoir pas de poids grâce à la structure de support en verre transparent. Meridiano « une force de la nature ».

Meridiano is inspired by nature which, not at all invasive, enters our homes with the shapes softened by the craftsman's hand to make our habitat comfortable and beautiful. A wild oak top with bark-edges seems to be weightless thanks to the structure in transparent glass. Meridiano "a force of nature".



37

**MERIDIANO**  
design Altacom

**Base/Piédement/Base:** vetro trasparente  
**Piano/Plateau/Top:** rovere nodato W04

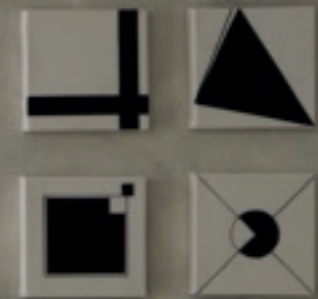



**FINITURE PIANO**  
*FINITIONS PLATEAU*  
**TOP FINISHES**

**NOBILITATO**  
**/ MÉLAMINE**  
**/ MELAMINE**

- N05 Bianco matrix
- N20 Natural halifax oak
- N21 Pino jackson
- N23 Cemento
- N24 Ardesia
- N25 Vintage chiaro
- N30 Morera
- N33 Resina silver
- N34 Resina grigio cenere
- N35 Rovere nodato caramel
- N36 Olmo moka

**LACCATO**  
**/ LAQUÉ**  
**/ LACQUERED**

**Poros aperto**  
 / Pores ouverts / Open pore

- L31 Bianco luce
- L32 Bianco panna
- L33 Bianco vela
- L34 Grigio corda
- L35 Grigio canapa
- L39 Rosso aragosta
- L40 Tortora

**EFFETTO MALTA**  
**/ EFFET-BÉTON**  
**/ MORTAR-LOOK**

- E01 Corten black
- E02 Corten gold
- E03 Corten silver
- E04 Metalli vissuti nichel
- E05 Metalli vissuti rame
- E06 Beton tortora
- E07 Beton nero
- E08 Beton grigio scuro
- E09 Beton grigio chiaro
- E10 Pietra spatolata tortora
- E11 Pietra spatolata notte
- E12 Pietra spatolata cenere
- E13 Pietra spatolata perla
- E14 Pietra spatolata antracite
- E15 Pietra spatolata travertino
- E17 Pietra spatolata ardesia alluminio
- E19 Bianco assoluto

**ROVERE IMPIALLACCIATO**  
**/ PLACAGE CHÊNE**  
**/ OAK VENEER**

- W01 Rovere naturale
- W02 Rovere grigio
- W03 Rovere tabacco
- W04 Rovere nodato
- W06 Rovere juta
- W07 Rovere fumé

**Tavolo da pranzo fisso, gambe in vetro trasparente, piano in nobilitato, legno bordo corteccia o effetto malta.**

Table de repas fixe, piétement en verre transparent, plateau mélamine, bois chants écorce ou effet-béton.

Fixed dining table with transparent glass legs, top in melamine, wood with bark edges or mortar-look.

**Tavolo da pranzo allungabile, gambe in vetro trasparente, piano in nobilitato, legno bordo corteccia o effetto malta, 2 prolunghe interne.**

Table de repas extensible avec 2 rallonges intégrées, piétement en verre transparent, plateau mélamine, bois chants écorce ou effet-béton.

Transparent glass legs extending dining table, top in melamine, wood with bark edges or mortar-look, 2 inside extensions.

**FINITURE BASE**  
**FINITIONS PIÉTEMENT**  
**BASE FINISHES**

**VETRO**  
**/ VERRE**  
**/ GLASS**

Vetro trasparente

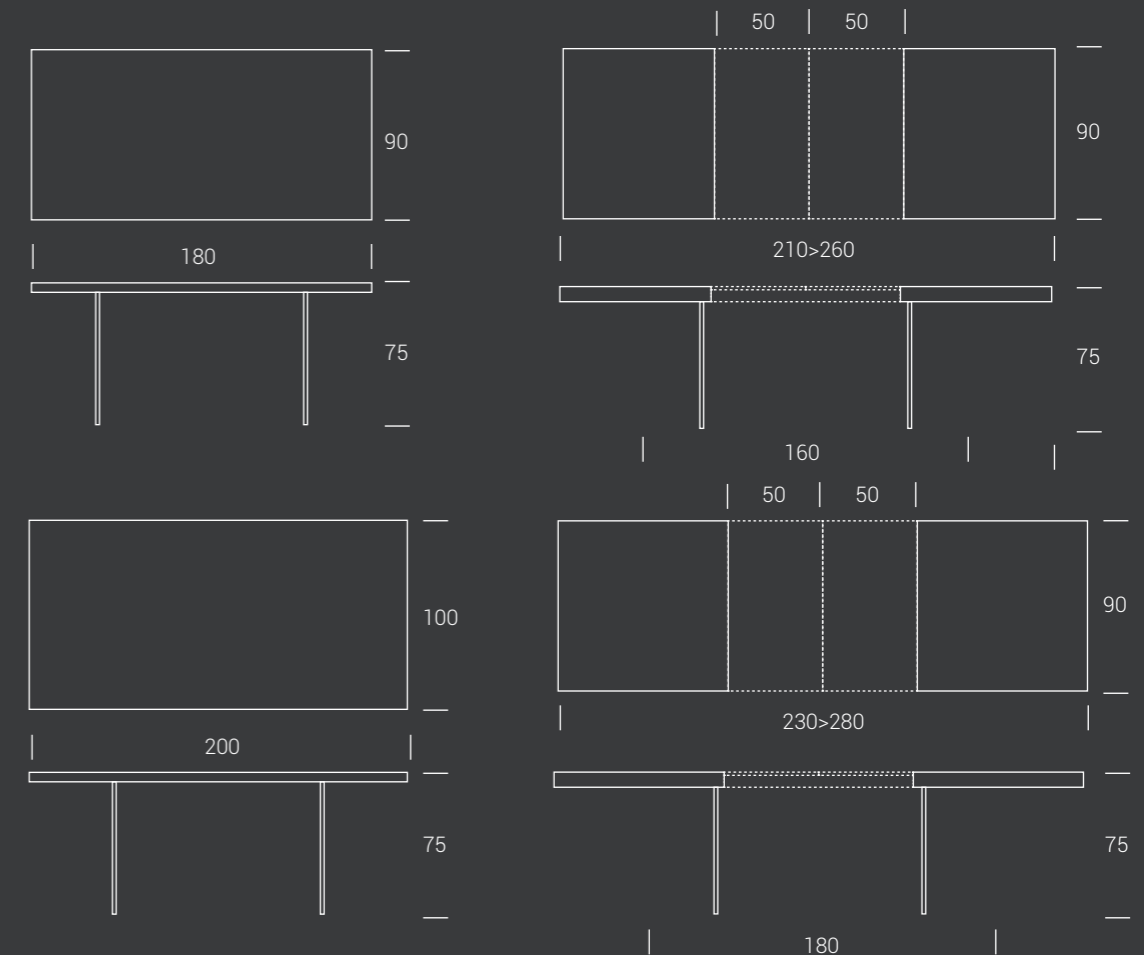

# ICEBERG

ICEBERG É UN TAVOLO DALLA STRUTTURA ARCHITETTONICA AD INTRECCIO IN METALLO GRAFITE. DISPONIBILE IN DUE DIMENSIONI DI PIANO, SI CONTRADDISTINGUE PER UN DESIGN FORTEMENTE ACCATTIVANTE. ICEBERG METTE IN MOSTRA LA SUA INCLINAZIONE NATURALE ALL'ACCOGLIENZA NELLE SUPERFICI TATTILI IN ROVERE NODATO E NELLE FORME ERGONOMICHE DEL PIANO.

Iceberg est une table à la structure architecturale à entrelacement de métal finition graphite. Disponible en deux tailles, elle se caractérise par un design très attractif. Iceberg met en valeur sa tendance naturelle à l'accueil dans les surfaces tactiles en chêne noueux et dans les formes ergonomiques du plateau.

Iceberg is a table with an architectural structure by a plot of metal in graphite finish. Available in two sizes, it is characterized by a highly captivating design. Iceberg showcases its natural inclination to hospitality through the tactile surfaces in oak and through the ergonomic shapes of the top.



38

**ICEBERG**  
design Altacom

**Base/Pièment/Base:** verniciato grafite goffrato M11  
**Piano/Plateau/Top:** rovere nodato W04





**FINITURE PIANO**  
**FINITIONS PLATEAU**  
**TOP FINISHES**

**NOBILITATO**  
**/ MÉLAMINE**  
**/ MELAMINE**

- N05 Bianco matrix
- N20 Natural halifax oak
- N21 Pino jackson
- N23 Cemento
- N24 Ardesia
- N25 Vintage chiaro
- N30 Morera
- N33 Resina silver
- N34 Resina grigio cenere
- N35 Rovere nodato caramel
- N36 Olmo moka

**LACCATO**  
**/ LAQUÉ**  
**/ LACQUERED**

**Poro aperto**  
*/ Pores ouverts / Open pore*

- L31 Bianco luce
- L32 Bianco panna
- L33 Bianco vela
- L34 Grigio corda
- L35 Grigio canapa
- L39 Rosso aragosta
- L40 Tortora

**EFFETTO MALTA**  
**/ EFFET-BÉTON**  
**/ MORTAR-LOOK**

- E01 Corten black
- E02 Corten gold
- E03 Corten silver
- E04 Metalli vissuti nichel
- E05 Metalli vissuti rame
- E06 Beton tortora
- E07 Beton nero
- E08 Beton grigio scuro
- E09 Beton grigio chiaro
- E10 Pietra spatolata tortora
- E11 Pietra spatolata notte
- E12 Pietra spatolata cenere
- E13 Pietra spatolata perla
- E14 Pietra spatolata antracite
- E15 Pietra spatolata travertino
- E17 Pietra spatolata ardesia alluminio
- E19 Bianco assoluto

**ROVERE IMPIALLACCIATO**  
**/ PLACAGE CHÊNE**  
**/ OAK VENEER**

- W01 Rovere naturale
- W02 Rovere grigio
- W03 Rovere tabacco
- W04 Rovere nodato
- W06 Rovere juta
- W07 Rovere fumé

**Tavolo da pranzo fisso, struttura in metallo, piano in nobilitato, legno bordo corteccia o effetto malta.**

**Table de repas fixe, structure en métal, plateau mélamine, bois chants écorce ou effet-béton.**

**Fixed dining table with metal frame, top in melamine, wood with bark edges or mortar-look.**

**FINITURE BASE**  
**FINITIONS PIÉTEMENT**  
**BASE FINISHES**

**METALLO**  
**/ MÉTAUX / METALS**

- M02 Verniciato grisou goffrato
- M03 Verniciato bianco opaco
- M04 Verniciato nero opaco
- M11 Verniciato grafite goffrato
- M12 Verniciato tortora opaco
- M19 Verniciato bronzo goffrato

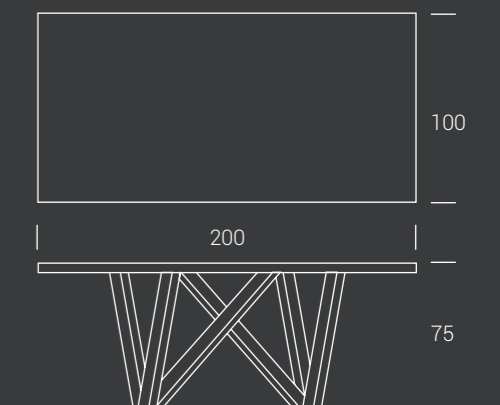
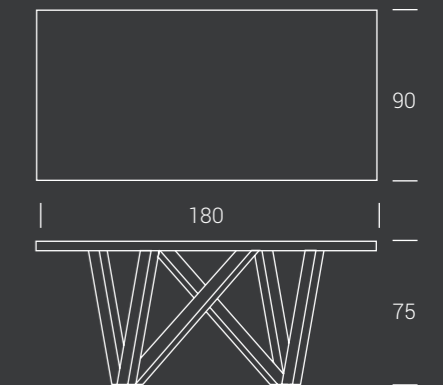

# STORM

STORM È IL TAVOLO ALLUNGABILE CHE PIÙ DI TUTTI ESPRIME QUOTIDIANITÀ E SOBRIETÀ: UN TAVOLO CONSIGLIATO PER CHI HA VOGLIA DI VIVERE LA CASA IN MODO PRATICO E INFORMALE, SENZA PREOCCUPARSI TROPPO, PER CHI INSOMMA PREDILIGE UN MOOD EASY E CASUAL.

Storm est la version plus sobre et simple parmi les tables extensibles: une table recommandée pour ceux qui veulent vivre la maison en toute praticité et informalité, sans soucis.

Storm is an extending kitchen table that mostly expresses daily life and sobriety. This table is recommended for those who want to live the house in a handy and informal way, without worrying too much. It has an easy and casual style.



39

**STORM**  
design Altacom

**Base/Piédement/Base:** verniciato bianco opaco M03  
**Piano/Plateau/Top:** nobilitato bianco matrix N05



STORM



39

STORM  
design Altacom

320

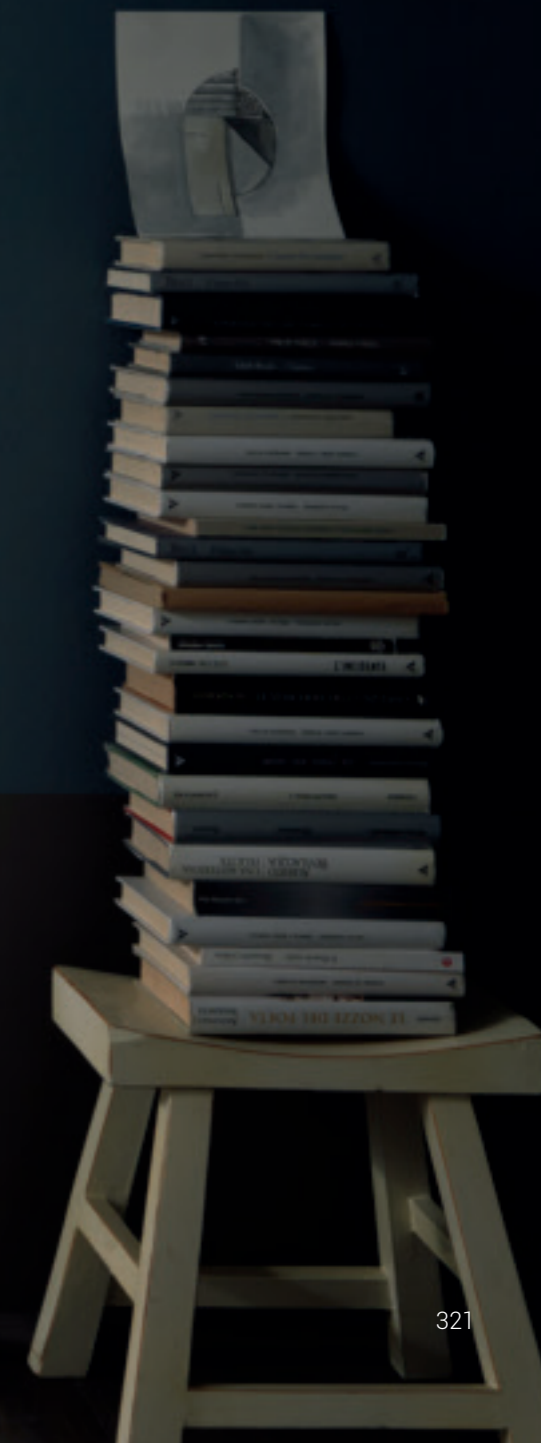

321



# STORM STORM DINÈ

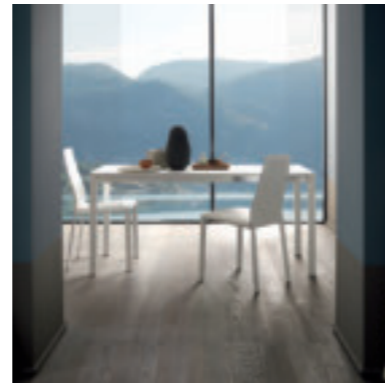

## FINITURE PIANO FINITIONS PLATEAU TOP FINISHES

### STORM

#### NOBILITATO / MÉLAMINE / MELAMINE

N05	Bianco matrix
N20	Natural halifax oak
N21	Pino jackson
N23	Cemento
N24	Ardesia
N25	Vintage chiaro
N30	Morera
N33	Resina silver
N34	Resina grigio cenere
N35	Rovere nodato caramel
N36	Olmo moka

#### VETRO / VERRE / GLASS

G01	Bianco
G02	Tortora
G03	Nero
G04	Bianco acidato
G05	Tortora acidato
G06	Nero acidato

### STORM DINÈ

#### NOBILITATO / MÉLAMINE / MELAMINE

N05	Bianco matrix
N20	Natural halifax oak
N21	Pino jackson
N23	Cemento
N24	Ardesia
N25	Vintage chiaro
N30	Morera
N33	Resina silver
N34	Resina grigio cenere
N35	Rovere nodato caramel
N36	Olmo moka

#### EFFETTO MALTA / EFFET-BÉTON / MORTAR-LOOK

E01	Corten black
E02	Corten gold
E03	Corten silver
E04	Metalli vissuti nichel
E05	Metalli vissuti rame
E06	Beton tortora
E07	Beton nero
E08	Beton grigio scuro
E09	Beton grigio chiaro
E10	Pietra spatolata tortora
E11	Pietra spatolata notte
E12	Pietra spatolata cenere
E13	Pietra spatolata perla
E14	Pietra spatolata antracite
E15	Pietra spatolata travertino
E17	Pietra spatolata ardesia alluminio
E19	Bianco assoluto

Tavolo da pranzo, struttura allungabile in metallo, meccanismo telescopico, piano in nobilitato o cristallo, 1 o 2 prolunghe interne a libro.

Table de repas avec 1 ou 2 rallonges portefeuille intégrées, structure en métal, plateau mélamine ou verre, mécanisme télescopique.

Metal frame dining table with telescopic extending mechanism, top in melamine or glass, 1 or 2 inside folded extensions.

### STORM DINÈ

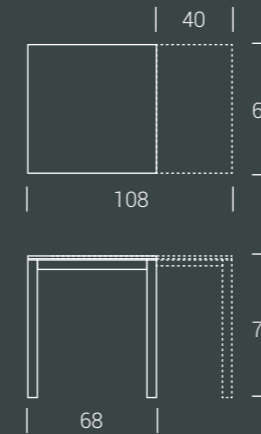

## FINITURE BASE FINITIONS PIÉTEMENT BASE FINISHES

#### METALLO / MÉTAUX / METALS

M02	Verniciato grisou goffrato
M03	Verniciato bianco opaco
M04	Verniciato nero opaco
M05	Cromo lucido
M11	Verniciato grafite goffrato
M12	Verniciato tortora opaco
M19	Verniciato bronzo goffrato

### STORM

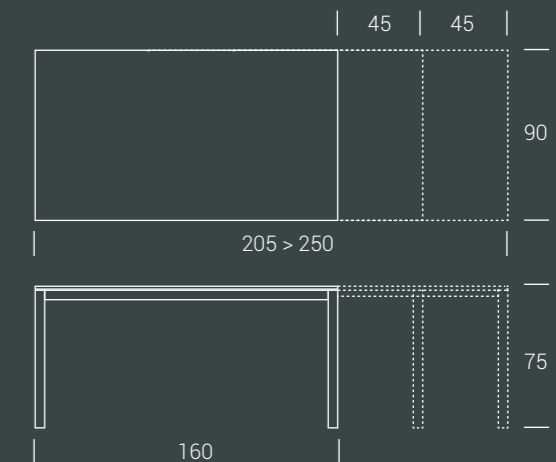
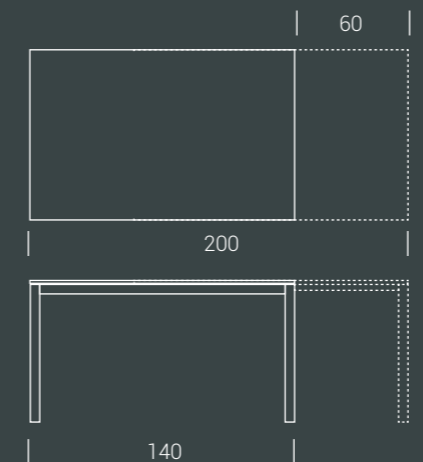
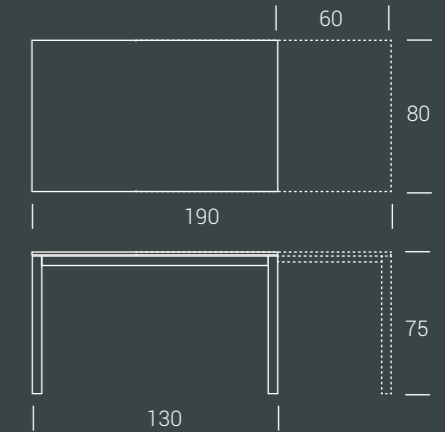
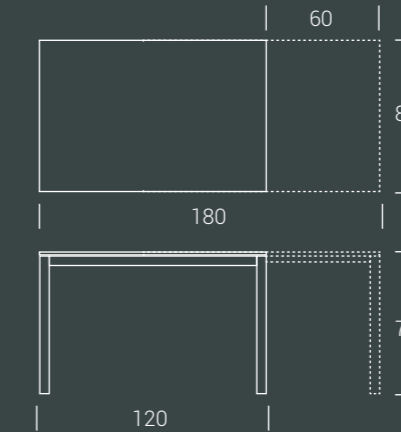
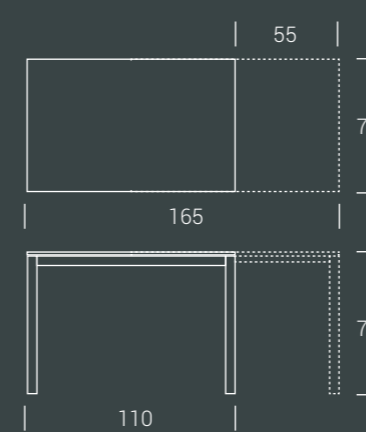

# BASIC

TAGLIO NETTO, SOBRIO E PULITO PER BASIC, IL TAVOLO ALLUNGABILE PER CHI NON AMA TROPPI ORNAMENTI MA PUNTA TUTTO SU POCHI COMPLEMENTI DI CARATTERE. UN ELOGIO ALLA SEMPLICITÀ E ALLA GENUINITÀ, QUESTO TAVOLO È PURA ELEGANZA.

Aspect marqué et sobre: Basic, la table extensible pour ceux qui n'aiment pas trop de détails mais qui préfèrent mettre l'accent sur quelques aspects de caractère. Un éloge de la simplicité et de la pureté, cette table est l'image de l'élégance.

The clear, sober and smooth cut of Basic makes it perfect for people who loves having few, great pieces with personality. With its elegance, it is a praise to simplicity and candor.



BASIC



# BASIC

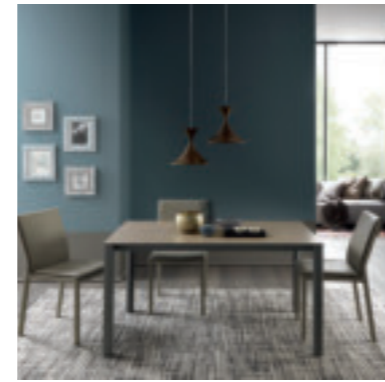

## FINITURE PIANO FINITIONS PLATEAU TOP FINISHES

### NOBILITATO / MÉLAMINE / MELAMINE

- N05 Bianco matrix
- N20 Natural halifax oak
- N21 Pino jackson
- N23 Cemento
- N24 Ardesia
- N25 Vintage chiaro
- N30 Morera
- N33 Resina silver
- N34 Resina grigio cenere
- N35 Rovere nodato caramel
- N36 Olmo moka

### LACCATO / LAQUÉ / LACQUERED

Poro aperto  
/ Pores ouverts / Open pore

- L31 Bianco luce
- L32 Bianco panna
- L33 Bianco vela
- L34 Grigio corda
- L35 Grigio canapa
- L39 Rosso aragosta
- L40 Tortora

### EFFETTO MALTA / EFFET-BÉTON / MORTAR-LOOK

- E01 Corten black
- E02 Corten gold
- E03 Corten silver
- E04 Metalli vissuti nichel
- E05 Metalli vissuti rame
- E06 Beton tortora
- E07 Beton nero
- E08 Beton grigio scuro
- E09 Beton grigio chiaro
- E10 Pietra spatolata tortora
- E11 Pietra spatolata notte
- E12 Pietra spatolata cenere
- E13 Pietra spatolata perla
- E14 Pietra spatolata antracite
- E15 Pietra spatolata travertino
- E17 Pietra spatolata ardesia alluminio
- E19 Bianco assoluto

### ROVERE IMPIALLACCIATO / PLACAGE CHÊNE / OAK VENEER

- W01 Rovere naturale
- W02 Rovere grigio
- W03 Rovere tabacco
- W04 Rovere nodato
- W06 Rovere juta
- W07 Rovere fumé

### LEGNO MASSICCIO / BOISS MASSIF / SOLID WOOD

- W21 Rovere vecchio massiccio termotrattato
- W32 Rovere vecchio massiccio naturale
- W33 Rovere vecchio massiccio grigio

### CERAMICA / CÉRAMIQUE / CERAMIC

- K01 Fokos sale
- K02 Fokos terra
- K03 Fokos piombo
- K04 Noir desir lucido
- K05 Bianco statuario venato lucido

### VETRO / VERRE / GLASS

- G01 Bianco
- G02 Tortora
- G03 Nero
- G04 Bianco acidato
- G05 Tortora acidato
- G06 Nero acidato

LAMINAM®

Tavolo da pranzo, struttura allungabile in metallo, meccanismo telescopico, piano in nobilitato, legno, effetto malta, vetro o ceramica. Disponibile con meccanismo tradizionale e allunghe a libro o con meccanismo super allungabile con allunghe interne.

Table de repas, structure en métal, plateau mélamine, verre, bois, laqué, effet-béton ou céramique, mécanisme télescopique. Disponible avec mécanique traditionnelle et rallonges porte-feuille, ou mécanique super-extensible avec rallonges intégrées.

Metal frame dining table with telescopic extending mechanism, top in melamine, glass, stained wood, mortar-look or ceramic. Available with traditional mechanism and book extensions or with super-extensible mechanism and inside extensions.

## FINITURE BASE FINITIONS PIÉTEMENT BASE FINISHES

### METALLO / MÉTAUX / METALS

- M02 Verniciato griso gofrato
- M03 Verniciato bianco opaco
- M04 Verniciato nero opaco
- M05 Cromo lucido
- M11 Verniciato grafite gofrato
- M12 Verniciato tortora opaco
- M19 Verniciato bronzo gofrato

### BASIC SUPER

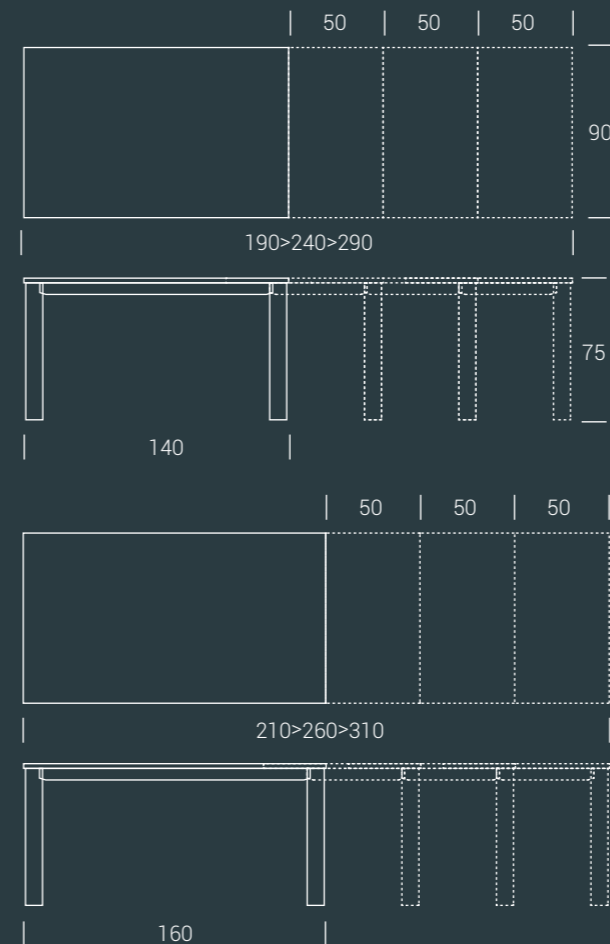

### BASIC

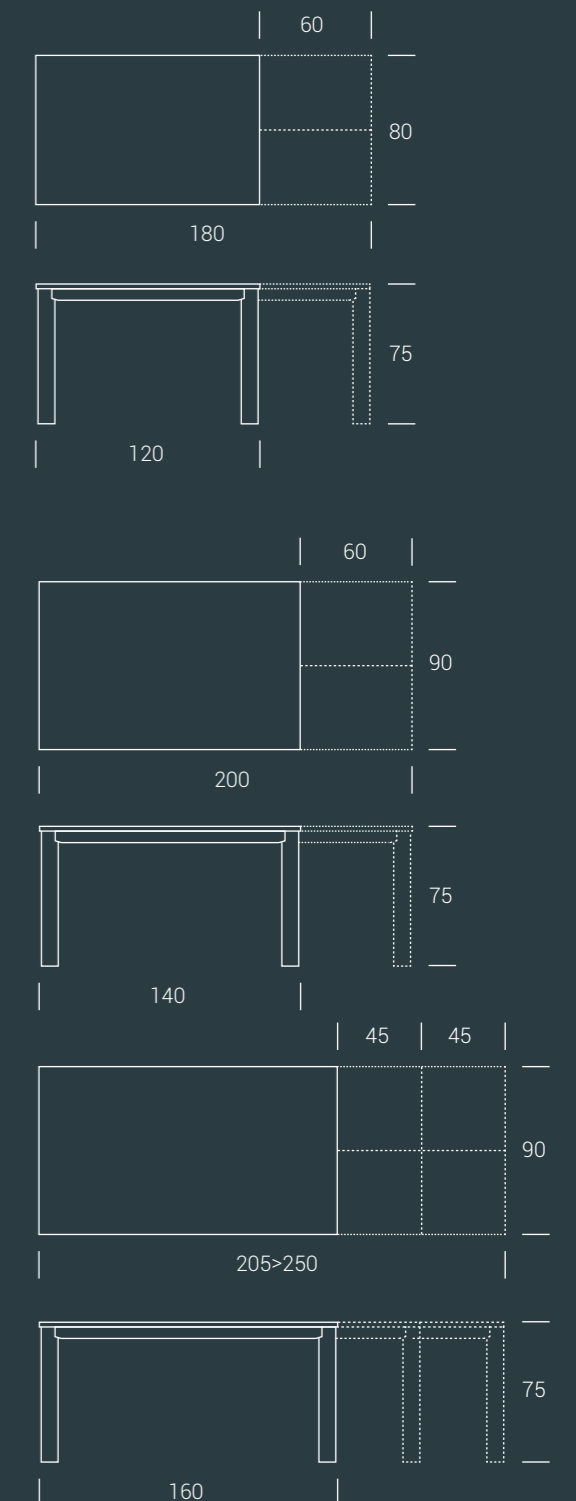

## SLALOM

SLALOM È IL TAVOLO ALLUNGABILE CHE PIACE A CHI NOTA ANCHE I DETTAGLI PIÙ NASCOSTI CHE NON TUTTI RICONOSCONO AL PRIMO SGUARDO: ALL'APPARENZA È UN TAVOLO MOLTO SEMPLICE, MA IN REALTÀ LE GAMBE POSIZIONATE IN MODO INUSUALE E IL PIANO CHE SEMBRA QUASI SOSPESO, TANTO È LEGGERO, DONANO AL TAVOLO QUELLA PARTICOLARITÀ NELLA SEMPLICITÀ CHE LO RENDE UNICO.

Slalom est la table extensible pour ceux qui remarquent aussi les détails les plus profonds, les plus cachés à première vue: en apparence il s'agit d'une table très simple, mais en effet les pieds inhabituels et le plateau presque suspendu, en font une table unique et minimale.

Slalom is an extending table suited for people who notice even the most hidden details that are not visible to anyone at first sight. It seems like an easy table but indeed its legs are positioned in a very unusual way and the top seems like suspended in the air, giving it a light tone and a peculiar characteristic that makes it unique.



41

**SLALOM**  
design Altacom

**Base/Piédement/Base:** verniciato nero opaco M04  
**Piano/Plateau/Top:** effetto malta pietra spatolata travertino E15

SLALOM





# SLALOM

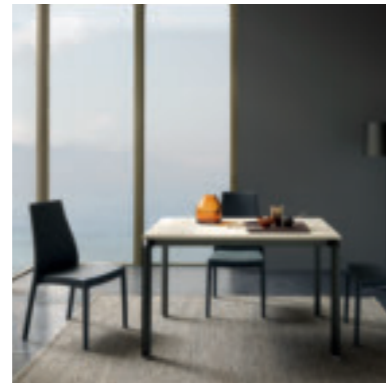

## FINITURE PIANO FINITIONS PLATEAU TOP FINISHES

### NOBILITATO / MÉLAMINE / MELAMINE

- N05 Bianco matrix
- N20 Natural halifax oak
- N21 Pino jackson
- N23 Cemento
- N24 Ardesia
- N25 Vintage chiaro
- N30 Morera
- N33 Resina silver
- N34 Resina grigio cenere
- N35 Rovere nodato caramel
- N36 Olmo moka

### LACCATO / LAQUÉ / LACQUERED

Porro aperto  
/ Pores ouverts / Open pore

- L31 Bianco luce
- L32 Bianco panna
- L33 Bianco vela
- L34 Grigio corda
- L35 Grigio canapa
- L39 Rosso aragosta
- L40 Tortora

### ROVERE IMPIALLACCIATO / PLACAGE CHÊNE / OAK VENEER

- W01 Rovere naturale
- W02 Rovere grigio
- W03 Rovere tabacco
- W04 Rovere nodato
- W06 Rovere juta
- W07 Rovere fumé

### LEGNO MASSICCIO / BOISS MASSIF / SOLID WOOD

- W21 Rovere vecchio massiccio termotrattato
- W32 Rovere vecchio massiccio naturale
- W33 Rovere vecchio massiccio grigio

### CERAMICA / CÉRAMIQUE / CERAMIC

- K01 Fokos sale
- K02 Fokos terra
- K03 Fokos piombo
- K04 Noir desir lucido
- K05 Bianco statuario venato lucido

### VETRO / VERRE / GLASS

- G01 Bianco
- G02 Tortora
- G03 Nero
- G04 Bianco acidato
- G05 Tortora acidato
- G06 Nero acidato

### EFFETTO MALTA / EFFET-BÉTON / MORTAR-LOOK

- E01 Corten black
- E02 Corten gold
- E03 Corten silver
- E04 Metalli vissuti nichel
- E05 Metalli vissuti rame
- E06 Beton tortora
- E07 Beton nero
- E08 Beton grigio scuro
- E09 Beton grigio chiaro
- E10 Pietra spatolata tortora
- E11 Pietra spatolata notte
- E12 Pietra spatolata cenere
- E13 Pietra spatolata perla
- E14 Pietra spatolata antracite
- E15 Pietra spatolata travertino
- E17 Pietra spatolata ardesia alluminio
- E19 Bianco assoluto

**Tavolo da pranzo, struttura allungabile in metallo, meccanismo telescopico, piano in nobilitato, legno, effetto malta, vetro o ceramica. Disponibile con meccanismo tradizionale e allunghe a libro o con meccanismo super allungabile con allunghe interne.**

Table de repas, structure en métal, plateau mélamine, verre, bois, laqué, effet-béton ou céramique, mécanisme télescopique. Disponible avec mécanique traditionnelle et rallonges porte-feuille, ou mécanique super-extensible avec rallonges intégrées.

Metal frame dining table with telescopic extending mechanism, top in melamine, glass, stained wood, mortar-look or ceramic. Available with traditional mechanism and book extensions or with super-extensible mechanism and inside extensions.

## FINITURE BASE FINITIONS PIÉTEMENT BASE FINISHES

### METALLO / MÉTAUX / METALS

- M02 Verniciato grisou goffrato
- M03 Verniciato bianco opaco
- M04 Verniciato nero opaco
- M05 Cromo lucido
- M11 Verniciato grafite goffrato
- M12 Verniciato tortora opaco
- M19 Verniciato bronzo goffrato

### SLALOM SUPER

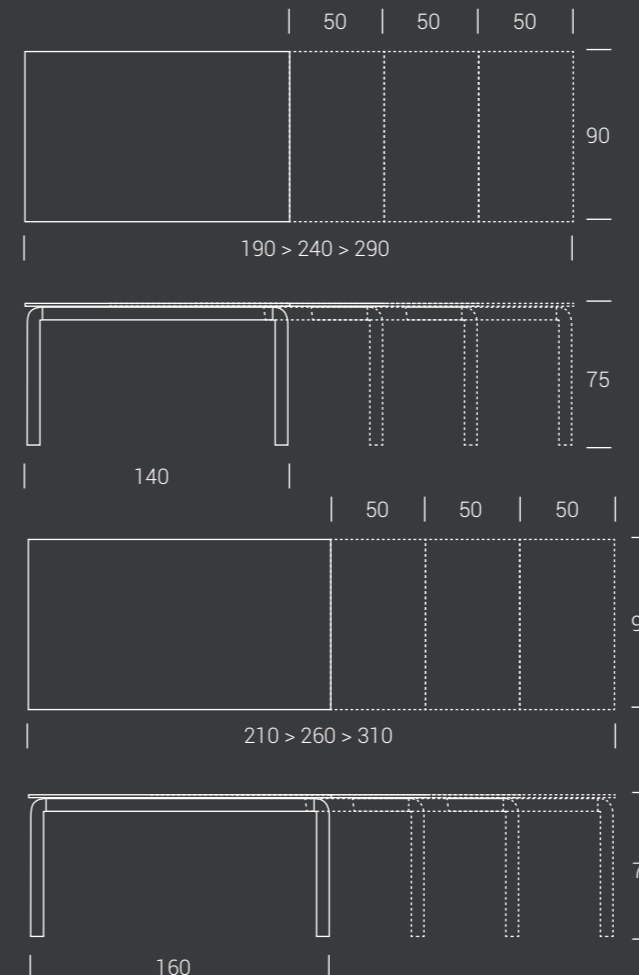

### SLALOM

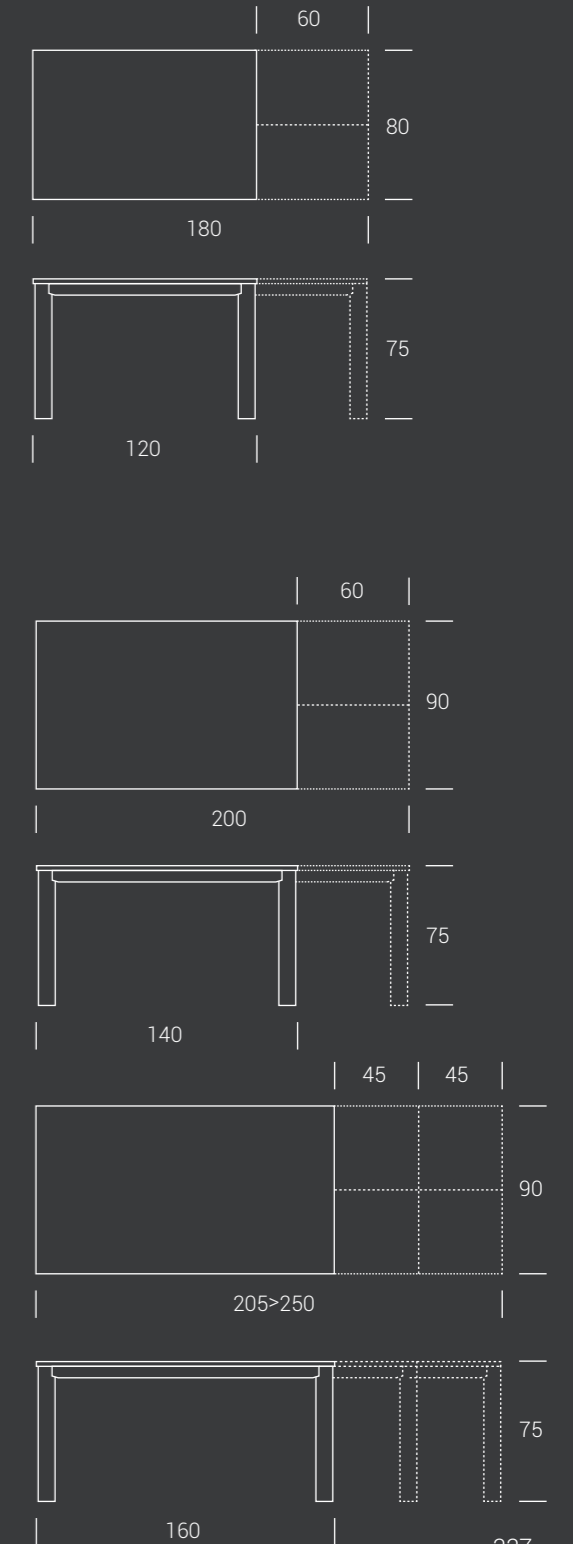

## TOWER MAXI

UN TAVOLO ALLUNGABILE CHE SA REGALARE GRANDI, ANZI ENORMI EMOZIONI. NELLA VERSIONE DA SOGGIORNO È PICCOLO E DISCRETO, MA QUANDO SI APRE DIVENTA UN TAVOLO DA PRANZO DI QUASI 5 METRI DI LUNGHEZZA, PER OSPITARE VERAMENTE TUTTI GLI INVITATI CHE VUOI. DA TOWER MAXI PUOI SOLO LASCIARTI PIACEVOLMENTE SORPRENDERE.

Une table extensible qui donne de grandes émotions. En position fermée elle est petite et discrète, mais son extension jusqu'à presque 5 mètres permet d'accueillir à table tout le monde: Tower Maxi est une table facilement étonnante, n'est-ce pas?

Tower Maxi is a table that gives real emotions. In the living room version is small and discrete but when open it gets to 5 metres length, to host all the friends you want. It's a massive solution.



42

**TOWER MAXI**  
design Altacom

**Base/Piédement/Base:** inox M01  
**Piano/Plateau/Top:** nobilitato rovere nodato caramel N35



TOWER MAXI



# TOWER MAXI



**Tavolo da pranzo allungabile, base centrale in metallo, piano in nobilitato, legno o effetto-malta, 6 prolunghe interne, gambe pieghevoli di supporto.**

**Table de repas avec piétement central en métal, plateau melamine, bois, ou effet-béton, 6 rallonges intégrées, pieds pliables à support des rallonges.**

**Extending dining table with metal base, top in melamine, wood or mortar-look, 6 inside extensions, supporting folding legs.**

## FINITURE PIANO FINITIONS PLATEAU TOP FINISHES

### NOBILITATO / MÉLAMINE / MELAMINE

- N05 Bianco matrix
- N20 Natural halifax oak
- N21 Pino jackson
- N23 Cemento
- N24 Ardesia
- N25 Vintage chiaro
- N30 Morera
- N33 Resina silver
- N34 Resina grigio cenere
- N35 Rovere nodato caramel
- N36 Olmo moka

### LACCATO / LAQUÉ / LACQUERED

Poro aperto  
/ Pores ouverts / Open pore

- L31 Bianco luce
- L32 Bianco panna
- L33 Bianco vela
- L34 Grigio corda
- L35 Grigio canapa
- L39 Rosso aragosta
- L40 Tortora

### EFFETTO MALTA / EFFET-BÉTON / MORTAR-LOOK

- E01 Corten black
- E02 Corten gold
- E03 Corten silver
- E04 Metalli vissuti nichel
- E05 Metalli vissuti rame
- E06 Beton tortora
- E07 Beton nero
- E08 Beton grigio scuro
- E09 Beton grigio chiaro
- E10 Pietra spatolata tortora
- E11 Pietra spatolata notte
- E12 Pietra spatolata cenere
- E13 Pietra spatolata perla
- E14 Pietra spatolata antracite
- E15 Pietra spatolata travertino
- E17 Pietra spatolata ardesia alluminio
- E19 Bianco assoluto

### ROVERE IMPIALLACCIATO / PLACAGE CHÊNE / OAK VENEER

- W01 Rovere naturale
- W02 Rovere grigio
- W03 Rovere tabacco
- W04 Rovere nodato
- W06 Rovere juta
- W07 Rovere fumé

## FINITURE BASE FINITIONS PIÉTEMENT BASE FINISHES

### METALLO / MÉTAUX / METALS

- M01 Inox
- M02 Verniciato grisou goffrato
- M03 Verniciato bianco opaco
- M04 Verniciato nero opaco
- M11 Verniciato grafite goffrato
- M12 Verniciato tortora opaco
- M19 Verniciato bronzo goffrato

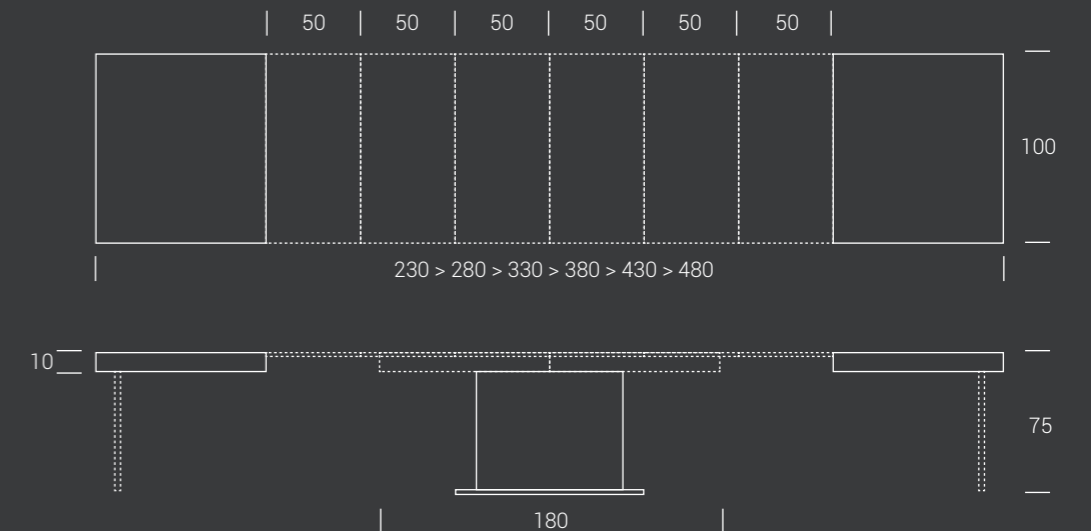

# CONTRACT

LA LINEA DI TAVOLINI E SGABELLI "CONTRACT" DI ALTACOM SI RIVELANO LA SOLUZIONE IDEALE PER ARREDARE AMBIENTI PROFESSIONALI CONFERENDO STILE E VERSATILITÀ DI UTILIZZO. TAVOLINI E SGABELLI FACILMENTE REGOLABILI IN ALTEZZA INVENTANO NUOVI MODI PER UNA CONVIVIALITÀ CHE PONE L'ACCENTO SULLA MODERNITÀ. LE SEDIE DELLA COLLEZIONE ALTACOM SONO ACCOSTABILI AI DIFFERENTI CONTESTI D'ARREDO IN VIRTÙ DI UN DESIGN SOBRIO E RAFFINATO. LE LORO SEDUTE SONO ERGONOMICHE PERCIÒ CONFORTEVOLI, I LORO RIVESTIMENTI SONO COSTITUITI DALLA SCELTA DI CINQUE CROMIE DI TENDENZA REALIZZATE IN PELLE, ECOPELLE ED ECOPELLE NABUK.

La famille « Contract » des tables réglables et des tabourets est la solution idéale pour meubler l'environnement professionnel, en donnant du style et de la versatilité. Des tables et des tabourets facilement réglables en hauteur, qui inventent de nouveaux moyens pour vivre la convivialité avec plus de modernité. Les chaises de la collection Altacom peuvent être combinées avec de différents environnements, grâce à leur design discret et élégant. Leurs assises sont ergonomiques et confortables, leurs revêtements sont disponibles en cinq couleurs de tendance, réalisées en cuir, eco-cuir et eco-cuir nabuk.

Altacom contract series of height adjustable tables and stools is the ideal solution to furnish professional locations with style and versatility of use. Table and stools easily adjustable in height create new ways to live conviviality with a touch of modernity. The chairs of Altacom collection can be matched to different furnished backgrounds thanks to their sober and elegant design. Their seating is ergonomic, which confers them comfort. The leather, ecoleather and nabuk ecoleather covering is available in five different trending colors.



## CENTER / PROFILO

IL TAVOLINO CENTER, REGOLABILE IN ALTEZZA MEDIANTE MECCANISMO A GAS PUÒ ESSERE ABBINATO ALLO SGABELLO DROP O PROFILO SECONDO I VOSTRI GUSTI E ABBINAMENTI FINITURE. LA SEDUTA, COMODA E VERSATILE, CONFERISCE AL "CONTRACT" CONTEMPORANEO MASSIMO COMFORT E PRATICITÀ.

La table Center, réglable en hauteur par vérin-gaz, peut être assortie au tabouret Drop ou Profilo, selon vos goûts et vos préférences. L'assise, confortable et versatile, donne du confort et du design, pour un Contract contemporain.

The table "Center", height-adjustable through a gas lifting mechanism, can be matched to the stool "Drop" or "Profilo" according to your taste. The comfortable and versatile seating gives the contemporary "Contract" collection maximum comfort and convenience.



44/45

CENTER / PROFILO  
design Altacom

CENTER Base/Piètement/Base: cromo lucido M05  
Piano/Plateau/Top: rovere nodato W04

PROFILO Base/Piètement/Base: cromo lucido M05  
Scocca/Coque/Shell: rovere nodato W04

## / CENTER



**Tavolo regolabile in altezza con meccanismo a gas, piano in vetro, legno o effetto malta, struttura in metallo, disponibile in due versioni di altezza. Disponibile a richiesta versione fissa.**

**Table réglable en hauteur par vérin-gaz avec plateau verre, bois, ou effet-béton, piétement en métal, disponible en deux hauteurs. Disponible en version fixe sur demande.**

**Height adjustable table with glass, wood or mortar-look top, metal base, gas lifting, available in two heights. Available in fixed version upon request.**

## / PROFILO

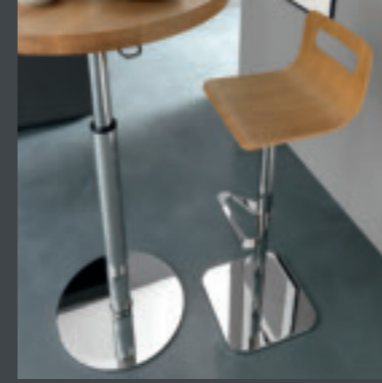

**Sgabello girevole in metallo, meccanismo a gas regolabile in altezza da cm 52 a cm 71, scocca in cuoietto o rovere.**

**Tabouret tournant en métal, haussement par vérin-gaz de cm 52 à cm 71, coque en croûte de cuir sellier ou chêne.**

**Metal frame swivel stool, gas adjustable height from cm 52 to cm 71, shell in thick split leather or oak.**

## FINITURE PIANO FINITIONS PLATEAU TOP FINISHES

Poro aperto  
/ Pores ouverts  
/ Open pore

### VETRO / VERRE / GLASS

G01 Bianco  
G02 Tortora  
G03 Nero

### ROVERE IMPIALLACCIATO / PLACAGE CHÊNE / OAK VENEER

W01 Rovere naturale  
W02 Rovere grigio  
W03 Rovere tabacco  
W04 Rovere nodato  
W06 Rovere juta  
W07 Rovere fumé

### LACCATO / LAQUÉ / LACQUERED

L31 Bianco luce  
L32 Bianco panna  
L33 Bianco vela  
L34 Grigio corda  
L35 Grigio canapa  
L39 Rosso aragosta  
L40 Tortora

### EFFETTO MALTA / EFFET-BÉTON / MORTAR-LOOK

E01 Corten black  
E02 Corten gold  
E03 Corten silver  
E04 Metalli vissuti nichel  
E05 Metalli vissuti rame  
E06 Beton tortora  
E07 Beton nero  
E08 Beton grigio scuro  
E09 Beton grigio chiaro  
E10 Pietra spatolata tortora  
E11 Pietra spatolata notte  
E12 Pietra spatolata cenere  
E13 Pietra spatolata perla  
E14 Pietra spatolata antracite  
E15 Pietra spatolata travertino  
E17 Pietra spat. ardesia alluminio  
E19 Bianco assoluto

## FINITURE FINITIONS FINISHES

### CUOIETTO / CROÛTE DE CUIR / SPLIT LEATHER

C01 Bianco  
C02 Avorio  
C03 Sand  
C05 Grigio chiaro  
C08 Moka  
C09 Grigio titanio  
C10 Nero  
C11 Tortora

### ROVERE IMPIALLACCIATO / PLACAGE CHÊNE / OAK VENEER

W01 Rovere naturale  
W02 Rovere grigio  
W03 Rovere tabacco  
W04 Rovere nodato  
W06 Rovere juta  
W07 Rovere fumé

## FINITURE BASE FINITIONS PIÉTEMENT BASE FINISHES

### METALLO / MÉTAUX / METALS

M02 Verniciato grisou goffrato  
M03 Verniciato bianco opaco  
M04 Verniciato nero opaco  
M05 Cromo lucido  
M11 Verniciato grafite goffrato  
M12 Verniciato tortora opaco  
M19 Verniciato bronzo goffrato

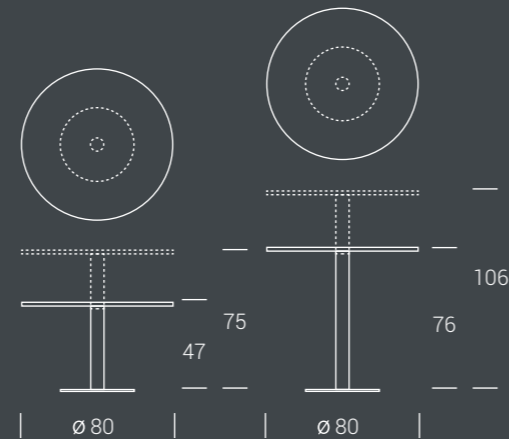

## FINITURE BASE FINITIONS PIÉTEMENT BASE FINISHES

### METALLO / MÉTAUX / METALS

M02 Verniciato grisou goffrato  
M03 Verniciato bianco opaco  
M04 Verniciato nero opaco  
M05 Cromo lucido  
M11 Verniciato grafite goffrato  
M12 Verniciato tortora opaco  
M19 Verniciato bronzo goffrato

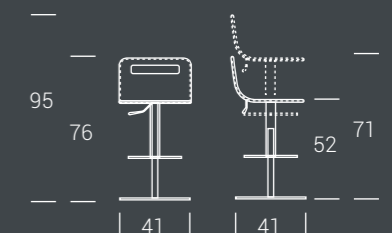



## OUTLINE / DROP

BENVENUTI NELLO SPAZIO PUBBLICO ARREDATO CON OUTLINE CHE SI PRESENTA IN FORMA "ERGONOMICA" CAPACE DI ASSECONDARE LE DIVERSE ESIGENZE DEL CONTRACT CONTEMPORANEO. GRAZIE ALLA FLESSIBILITÀ DELLE SUE POSIZIONI REGOLA L'ALTEZZA ATTRAVERSO IL MECCANISMO A GAS. LO SGABELLO DROP ANCH'ESSO REGOLABILE IN ALTEZZA INDUCE AD ACCOMODARSI PIACEVOLMENTE NELLA SEDUTA "MONOSCOCCA" PER GODERSI UNO SNACK O SORSEGGIARE UN DRINK IN PIACEVOLE COMPAGNIA.

Bienvenue dans l'espace public aménagé avec Outline, qui se présente avec sa forme ergonomique, capable de répondre aux différentes exigences du Contract contemporain. Grâce à la flexibilité de ses positions, elle règle son hauteur par son mécanisme vérin-gaz. Le tabouret Drop, également réglable en hauteur, invite à s'accommoder agréablement dans son assise, pour goûter un snack ou siroter un drink en bonne compagnie.

Welcome to the public space furnished with Outline, whose "ergonomic" shape can indulge the different needs of the contemporary contract. Thanks to its flexibility, the height can be adjusted through a gas mechanism. The Drop stool, adjustable in height as well, persuades people to make themselves at home on the unique seat, where they can enjoy a snack or a drink in company.



46/47

**OUTLINE / DROP**  
design Altacom

**OUTLINE** Base/Piédement/Base: verniciato grafite goffrato M11  
Piano/Plateau/Top: effetto malta pietra spatolata notte E11

**DROP** Base/Piédement/Base: verniciato grafite goffrato M11  
Scocca/Coque/Shell: rovere nodato W04

OUTLINE / DROP



46/47

OUTLINE / DROP  
design Altacom

## OUTLINE



**Tavolo regolabile in altezza con meccanismo a gas, piano in legno o effetto malta, struttura in metallo, disponibile in due versioni di altezza. Disponibile a richiesta versione fissa.**

**Table réglable en hauteur par vérin-gaz avec plateau bois, ou effet-béton, piétement en métal, disponible en deux hauteurs. Disponible en version fixe sur demande.**

**Height adjustable table with wood or mortar-look top, metal base, gas lifting, available in two heights. Available in fixed version upon request.**

## FINITURE PIANO FINITIONS PLATEAU TOP FINISHES

Poroso aperto  
/ Pores ouverts  
/ Open pore

### ROVERE IMPIALLACCIATO / PLACAGE CHÊNE / OAK VENEER

- W01 Rovere naturale
- W02 Rovere grigio
- W03 Rovere tabacco
- W04 Rovere nodato
- W06 Rovere juta
- W07 Rovere fumé

### LACCATO / LAQUÉ / LACQUERED

- L31 Bianco luce
- L32 Bianco panna
- L33 Bianco vela
- L34 Grigio corda
- L35 Grigio canapa
- L39 Rosso aragosta
- L40 Tortora

### EFFETTO MALTA / EFFET-BÉTON / MORTAR-LOOK

- E01 Corten black
- E02 Corten gold
- E03 Corten silver
- E04 Metalli vissuti nichel
- E05 Metalli vissuti rame
- E06 Beton tortora
- E07 Beton nero
- E08 Beton grigio scuro
- E09 Beton grigio chiaro
- E10 Pietra spatolata tortora
- E11 Pietra spatolata notte
- E12 Pietra spatolata cenere
- E13 Pietra spatolata perla
- E14 Pietra spatolata antracite
- E15 Pietra spatolata travertino
- E17 Pietra spat. ardesia alluminio
- E19 Bianco assoluto

## DROP



**Sgabello girevole in metallo, meccanismo a gas regolabile in altezza da cm 51 a cm 74, scocca in cuoietto o rovere.**

**Tabouret tournant en métal, haussement par vérin-gaz de cm 51 à cm 74, coque en croûte de cuir ou chêne.**

**Metal frame swivel stool, gas adjustable height from cm 51 to cm 74, split leather or oak shell.**

## FINITURE FINITIONS FINISHES

### CUOINETTO / CROÛTE DE CUIR / SPLIT LEATHER

- C01 Bianco
- C02 Avorio
- C03 Sand
- C05 Grigio chiaro
- C08 Moka
- C09 Grigio titanio
- C10 Nero
- C11 Tortora

### ROVERE IMPIALLACCIATO / PLACAGE CHÊNE / OAK VENEER

- W01 Rovere naturale
- W02 Rovere grigio
- W03 Rovere tabacco
- W04 Rovere nodato
- W06 Rovere juta
- W07 Rovere fumé

## FINITURE BASE FINITIONS PIÉTEMENT BASE FINISHES

### METALLO / MÉTAUX / METALS

- M02 Verniciato grisou goffrato
- M03 Verniciato bianco opaco
- M04 Verniciato nero opaco
- M05 Cromo lucido
- M11 Verniciato grafite goffrato
- M12 Verniciato tortora opaco
- M19 Verniciato bronzo goffrato

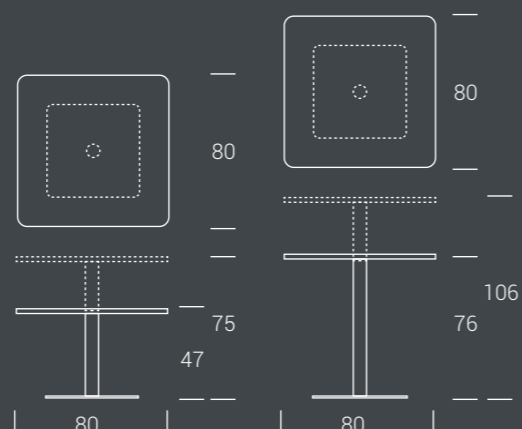

## FINITURE BASE FINITIONS PIÉTEMENT BASE FINISHES

### METALLO / MÉTAUX / METALS

- M02 Verniciato grisou goffrato
- M03 Verniciato bianco opaco
- M04 Verniciato nero opaco
- M05 Cromo lucido
- M11 Verniciato grafite goffrato
- M12 Verniciato tortora opaco
- M19 Verniciato bronzo goffrato

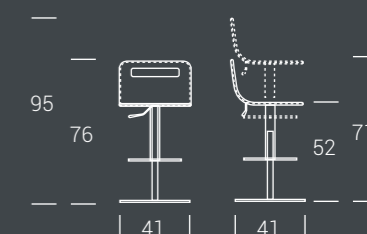

ITACA



48  
ITACA  
design Altacom

358



Base/Piètement/Base: cromo lucido M05  
Scocca/Coque/Shell: cuoietto bianco C01

359

ITACA



Sgabello in metallo,  
meccanismo a gas regolabile  
in altezza da cm 52 a cm 79,  
scocca rivestita in cuoietto.

Tabouret tournant en métal,  
haussement par vérin-gaz de cm  
52 à cm 79, revêtement coque en  
croûte de cuir sellier.

Metal frame stool, gas adjustable  
height from cm 52 to cm 79,  
split leather covering.

**FINITURE**  
**FINITIONS**  
**FINISHES**

**CUOIETTO**  
**/ CROÛTE DE CUIR**  
**/ SPLIT LEATHER**

C01	Bianco
C02	Avorio
C03	Sand
C05	Grigio chiaro
C08	Moka
C09	Grigio titanio
C10	Nero
C11	Tortora

**METALLO**  
**/ MÉTAUX**  
**/ METALS**

M05	Cromo lucido
-----	--------------

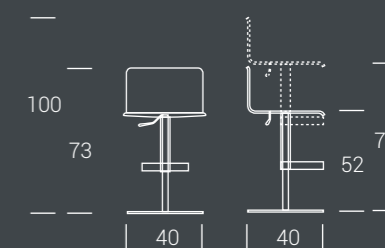

## NANETTE



Ecopelle nabuk grigio NB17

### ECOPELLE NABUK / ECO-CUIR NABUK / ECO-LEATHER NABUK

- NB07 Ecopelle nabuk grigio
- NB08 Ecopelle nabuk bianco
- NB17 Ecopelle nabuk tortora

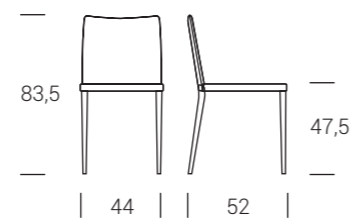

### ECOPELLE / ECO-CUIR / ECO-LEATHER

- EC01 Ecopelle bianco
- EC37 Ecopelle sabbia
- EC62 Ecopelle grafite
- EC91 Ecopelle nero

49

**NANETTE**  
design Altacom

**Sedia con struttura in metallo  
rivestita in ecopelle ed ecopelle  
nabuk.**

**Chaise avec structure en métal,  
revêtement en eco-cuir et eco-cuir nabuk.**

**Metal frame chair with soft eco-leather  
and soft eco-leather nabuk covering.**

## MARIANNA



Pelle bianco ottico P15

### PELLE / CUIR / LEATHER

- P11 Pelle nero
- P15 Pelle bianco ottico
- P16 Pelle sabbia
- P17 Pelle grafite

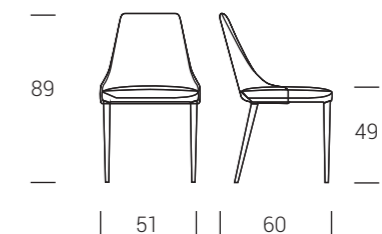

### ECOPELLE NABUK / ECO-CUIR NABUK / ECO-LEATHER NABUK

- NB07 Ecopelle nabuk grigio
- NB08 Ecopelle nabuk bianco
- NB17 Ecopelle nabuk tortora

50

**MARIANNA**  
design Altacom

**Sedia con struttura in metallo  
rivestita in pelle ed ecopelle  
nabuk.**

**Chaise avec structure en métal,  
revêtement en cuir et eco-cuir nabuk.**

**Metal frame chair with soft leather and  
soft eco-leather nabuk covering.**

## DANDY



Pelle grafite P17

### ECOPELLE NABUK / ECO-CUIR NABUK / ECO-LEATHER NABUK

- NB07 Ecopelle nabuk grigio
- NB08 Ecopelle nabuk bianco
- NB17 Ecopelle nabuk tortora

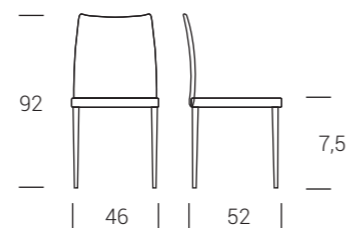

**Sedia con struttura in metallo rivestita in ecopelle ed ecopelle nabuk.**

**Chaise avec structure en métal, revêtement en eco-cuir et eco-cuir nabuk.**

**Metal frame chair with soft eco-leather and soft eco-leather nabuk covering.**

### ECOPELLE / ECO-CUIR / ECO-LEATHER

- EC01 Ecopelle bianco
- EC37 Ecopelle sabbia
- EC62 Ecopelle grafite
- EC91 Ecopelle nero

51

**DANDY**  
design Altacom

## MOLLY



Pelle sabbia P16

### PELLE / CUIR / LEATHER

- P11 Pelle nero
- P15 Pelle bianco ottico
- P16 Pelle sabbia
- P17 Pelle grafite

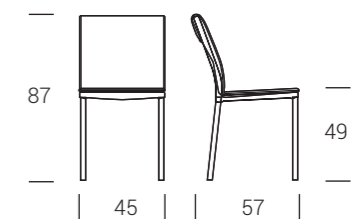

**Sedia con struttura in metallo rivestita in pelle.**

**Chaise avec structure en métal, revêtement en cuir.**

**Metal frame chair with soft leather covering.**

52

**MOLLY**  
design Altacom

Sedia con struttura in metallo rivestita in cuoietto.

Chaise avec structure en métal, revêtement en croûte de cuir sellier.

Metal frame chair with split leather covering.



**FINITURE**  
**FINITIONS**  
**FINISHES**

**CUOIETTO**  
**/ CROÛTE DE CUIR**  
**/ SPLIT LEATHER**

- C01 Bianco
- C02 Avorio
- C03 Sand
- C05 Grigio chiaro
- C08 Moka
- C09 Grigio titanio
- C10 Nero
- C11 Tortora





# HIPPO



Cuoietto bianco C01

## CUOIETTO / CROÛTE DE CUIR / SPLIT LEATHER

- C01 Bianco
- C02 Avorio
- C03 Sand
- C05 Grigio chiaro
- C08 Moka
- C09 Grigio titanio
- C10 Nero
- C11 Tortora

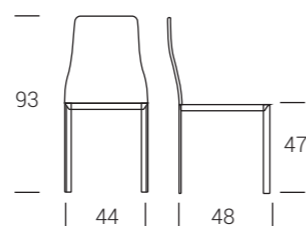

**Sedia con struttura in metallo rivestita in cuoietto.**

Chaise avec structure en métal, revêtement en croûte de cuir sellier.

Metal frame chair with thick split leather covering.

54

**HIPPO**  
design Altacom

# VESTA



Polipropilene argento Y04

## POLIPROPILENE / POLYPROPYLÈNE / POLYPROPYLENE

- Y01 Polipropilene bianco
- Y04 Polipropilene argento

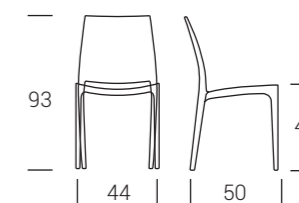

**Sedia in polipropilene rinforzato con fibra di vetro. Impilabile, adatta all'uso esterno.**

Chaise polypropylène renforcé fibre de verre. Empilable, utilisation en extérieur.

Chair in polypropylene reinforced with glass fiber. Stackable, also for outdoor use.

55

**VESTA**  
design Altacom

## N O R M A



Polipropilene antracite Y03

**POLIPROPILENE**  
/ POLYPROPYLÈNE  
/ POLYPROPYLENE

- Y01 Polipropilene bianco
- Y03 Polipropilene antracite
- Y06 Polipropilene marrone

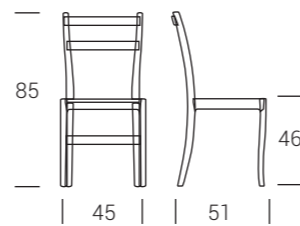

**Sedia in polipropilene rinforzato con fibra di vetro. Impilabile, adatta all'uso esterno.**

Chaise polypropylène renforcé fibre de verre. Empilable, utilisation en extérieur.

Chair in polypropylene reinforced with glass fiber. Stackable, also for outdoor use.

56

**NORMA**  
design Altacom

## F A B I A



Polipropilene tortora Y05

**POLIPROPILENE**  
/ POLYPROPYLÈNE  
/ POLYPROPYLENE

- Y01 Polipropilene bianco
- Y02 Polipropilene nero
- Y03 Polipropilene antracite
- Y05 Polipropilene tortora

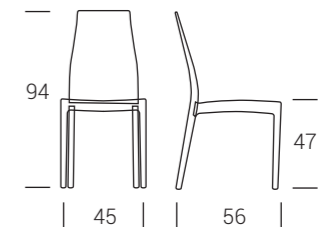

**Sedia in polipropilene rinforzato con fibra di vetro. Impilabile, adatta all'uso esterno.**

Chaise polypropylène renforcé fibre de verre. Empilable, utilisation en extérieur.

Chair in polypropylene reinforced with glass fiber. Stackable, also for outdoor use.

57

**FABIA**  
design Altacom

MATERIALI  
MATÉRIAUX  
MATERIALS

AVRETE A DISPOSIZIONE UNA VASTA GAMMA DI MATERIALI PER POTER SCEGLIERE LA SOLUZIONE PIÙ CONGENIALE AL VOSTRO ARREDO. DAI PIANI ALLA STRUTTURA DI TAVOLI E TAVOLINI ALLA SEDUTA DI SEDIE E SGABELLI NELLE DIVERSE FINITURE E CROMIE NELLE NUANCE PIÙ ATTUALI.

Vous aurez à disposition une large gamme de matériaux pour pouvoir choisir la solution qui mieux se décline à votre ambiance. Des plateaux jusqu'à la structure des tables, des tables relevables, aux assises des chaises et des tabourets dans les différentes finitions aux nuances les plus actuelles.

A large selection of materials is available to choose the best solution for your furniture. From the tops of the tables to the seating of chairs and stools with different finishes and colors in the most current nuances.

## FINITURE / FINITIONS / FINISHES

### METALLO / MÉTAUX / METALS

- M01 Inox
- M02 Vern. grisou gofrato
- M03 Vern. bianco opaco
- M04 Vern. nero opaco
- M05 Cromo lucido
- M07 Cromo opaco
- M09 Cromo nero lucido
- M10 Cromo nero opaco
- M11 Vernic. grafite gofrato
- M12 Vernic. tortora opaco
- M15 Oro lucido
- M19 Vernic. bronzo gofrato

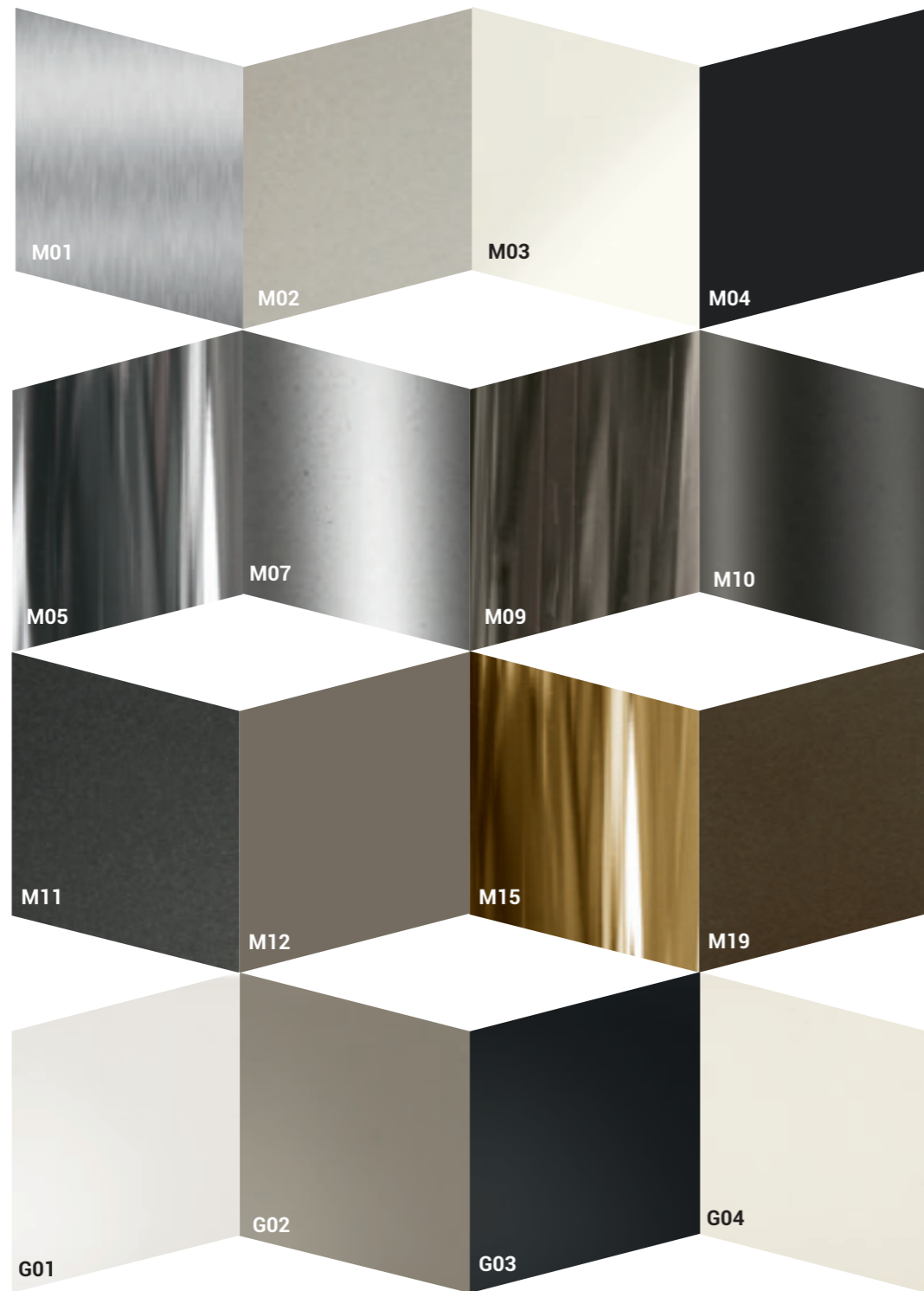

### VETRO / VERRE / GLASS

- G01 Bianco
- G02 Tortora
- G03 Nero
- G04 Bianco acidato
- G05 Tortora acidato
- G06 Nero acidato

## FINITURE / FINITIONS / FINISHES

### EFFETTO MALTA / EFFET BÉTON / MORTAR LOOK

- E01 Corten black
- E02 Corten gold
- E03 Corten silver
- E04 Metalli vissuti nichel
- E05 Metalli vissuti rame
- E06 Beton tortora
- E07 Beton nero
- E08 Beton grigio scuro
- E09 Beton grigio chiaro
- E10 Pietra spatolata tortora
- E11 Pietra spatolata notte
- E12 Pietra spatolata cenere
- E13 Pietra spatolata perla
- E14 Pietra spatolata antracite
- E15 Pietra spatolata travertino
- E17 Pietra spatolata ardesia alluminio
- E19 Bianco assoluto



## FINITURE / FINITIONS / FINISHES

La personalizzazione del prodotto dipende molto dalla scelta della finitura che si integra con forma e disegno e ne determina la sua "riuscita". Per la nostra collezione proponiamo un materiale nobile come il legno: rovere vecchio naturale e grigio dalle venature accentuate e larice fresato per un effetto "vintage".

La personnalisation du produit dépend beaucoup du choix de la finition qui s'intègre avec la forme et le design et en détermine la "réussite". Pour notre collection, nous proposons un matériel noble comme le bois: vieux chêne gris ou naturel au veinage accentué, mélèze fraisé pour obtenir un effet "vintage".

The products customization is mostly depending on the choice of the finish which integrates with the shape and design and determines its "success". For our collection we propose a noble material such as wood; natural or gray old oak with accentuated woodgrains and milled larch for a "vintage" effect.

### ROVERE IMPIALLACCIATO / PLACAGE CHÊNE / OAK VENEER

- W01 Rovere naturale
- W02 Rovere grigio
- W03 Rovere tabacco
- W04 Rovere nodato
- W06 Rovere juta
- W07 Rovere fumé



### LEGNO MASSICCIO / BOISS MASSIF / SOLID WOOD

- W21 Rovere vecchio massiccio termotrattato
- W32 Rovere vecchio massiccio naturale
- W33 Rovere vecchio massiccio grigio
- W34 Larice fresato

## FINITURE / FINITIONS / FINISHES

### NOBILITATO / MÉLAMINE / MELAMINE

- N05 Bianco matrix
- N20 Natural halifax oak
- N21 Pino jackson
- N23 Cemento
- N24 Ardesia
- N25 Vintage chiaro
- N30 Morera
- N33 Resina silver
- N34 Resina grigio cenere
- N35 Rovere nodato caramel
- N36 Olmo moka

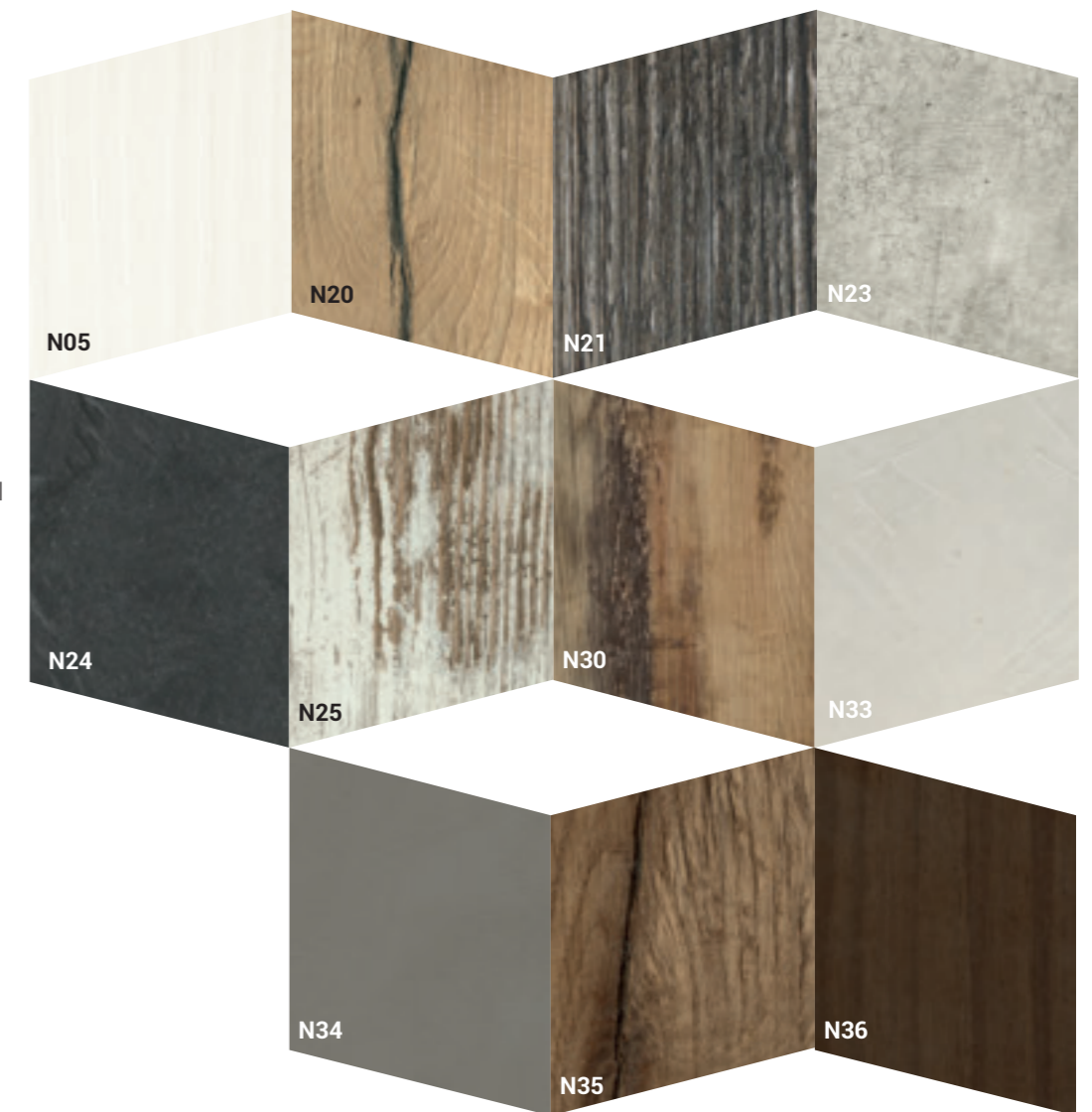

**FINITURE / FINITIONS / FINISHES**

**LACCATO OPACO  
/ LAQUÉ MAT  
/ MATT LACQUER**

- L51 Bianco luce
- L52 Bianco panna
- L53 Bianco vela
- L54 Grigio corda
- L55 Grigio canapa
- L59 Rosso aragosta
- L60 Tortora

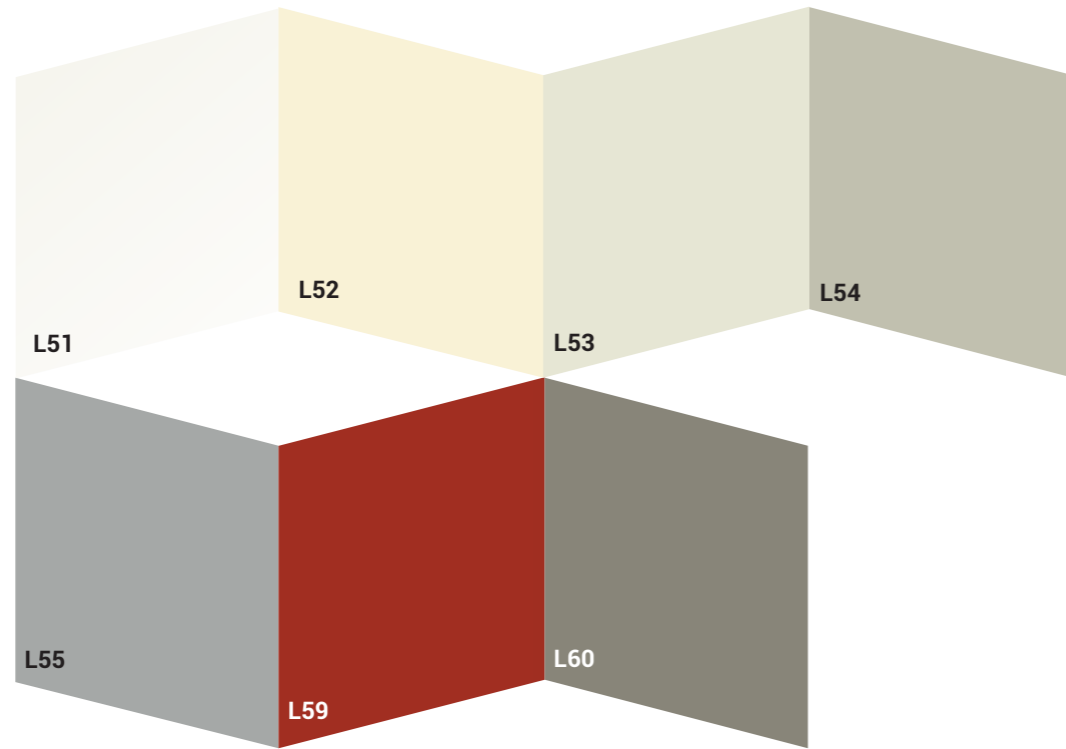

**LACCATO LUCIDO  
/ LAQUÉ BRILLANT  
/ HIGH GLOSS LACQUER**

- L01 Bianco luce



**FINITURE / FINITIONS / FINISHES**

**LACCATO PORO APERTO  
/ LAQUÉ PORES OUVERTS  
/ OPEN PORE LACQUER**

- L31 Bianco luce
- L32 Bianco panna
- L33 Bianco vela
- L34 Grigio corda
- L35 Grigio canapa
- L39 Rosso aragosta
- L40 Tortora

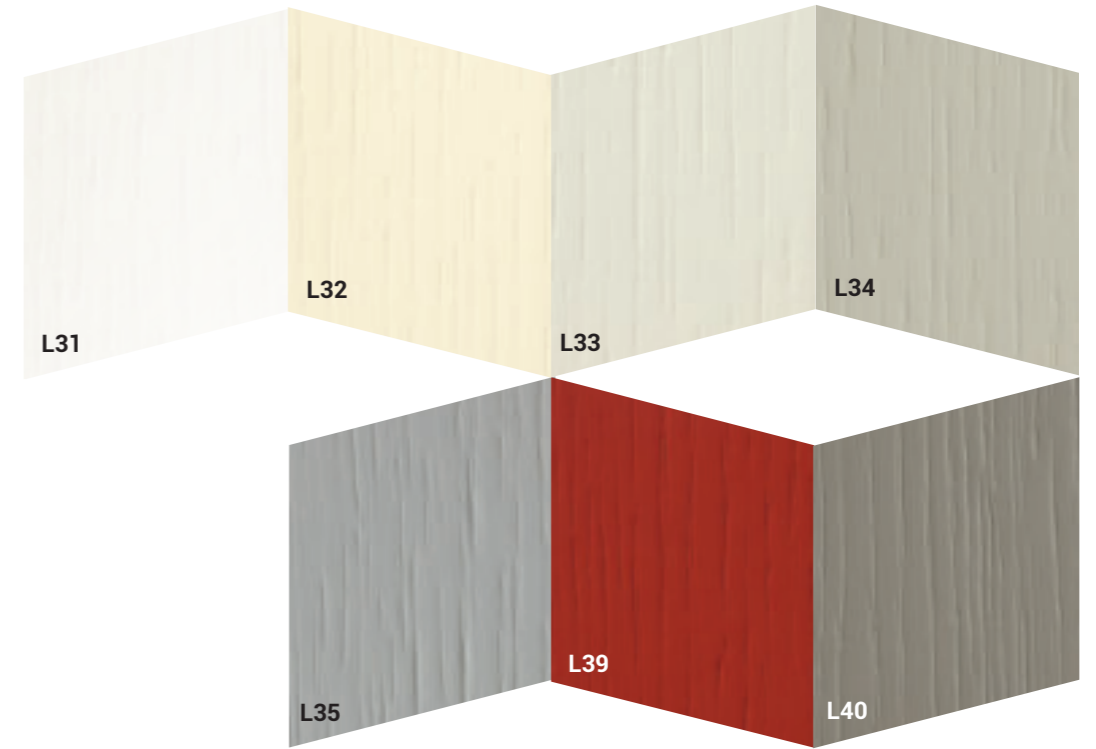

**CERAMICA  
/ CÉRAMIQUE  
/ CERAMIC**

- K01 Fokos sale
- K02 Fokos terra
- K03 Fokos piombo
- K04 Noir desir lucido
- K05 Bianco statuario venato lucido

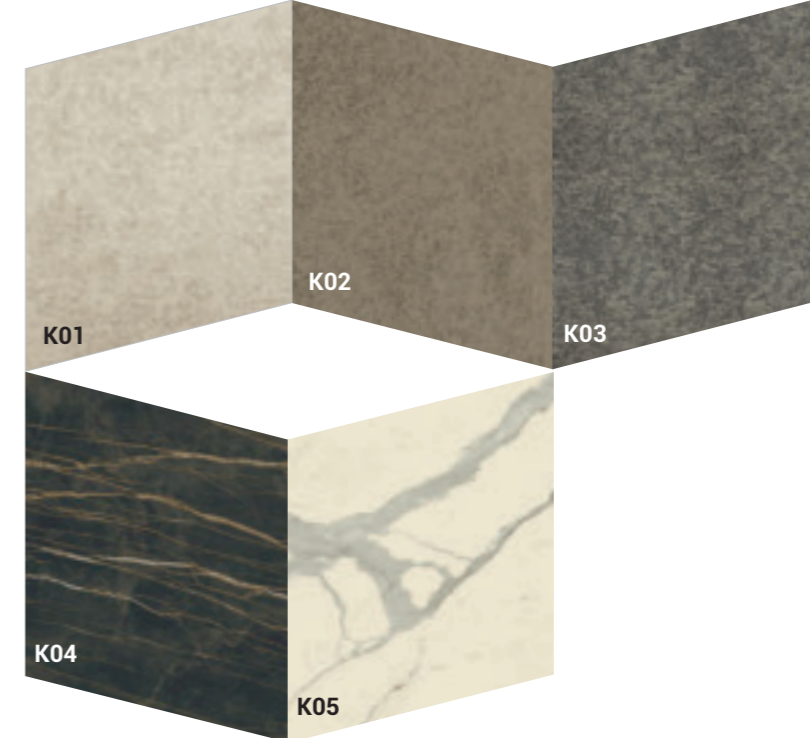

**LAMINAM**

## FINITURE / FINITIONS / FINISHES

Ad arricchire la vasta gamma di trasformabili, consolle e tavolini contribuisce decisamente la collezione di sedie Altacom per le quali sono disponibili rivestimenti in pelle, ecopelle ed ecopelle nabuk nelle nuances naturali del sabbia e del bianco o a contrasto la scelta del nero o del grafite.

À enrichir la gamme de tables relevables, consoles et tables repas contribue de manière décisive la collection de chaises Altacom pour lesquelles sont disponibles les revêtements en cuir, faux-cuir et faux-cuir nabuk dans les tons naturels du sable et du blanc ou, en contraste, le choix du noir ou du graphite.

To enrich the wide range of transforming tables, console-tables and dining tables, the collection of Altacom chairs gives its decided contribute: for them are available leather, eco-leather and nabuk eco-leather coverings in the natural nuances of sand and white or, as contrast, the choice of black or graphite.

### CUOINETTO / CROÛTE DE CUIR / SPLIT LEATHER

C01	Bianco
C02	Avorio
C03	Sand
C05	Grigio chiaro
C08	Moka
C09	Grigio titanio
C10	Nero
C11	Tortora

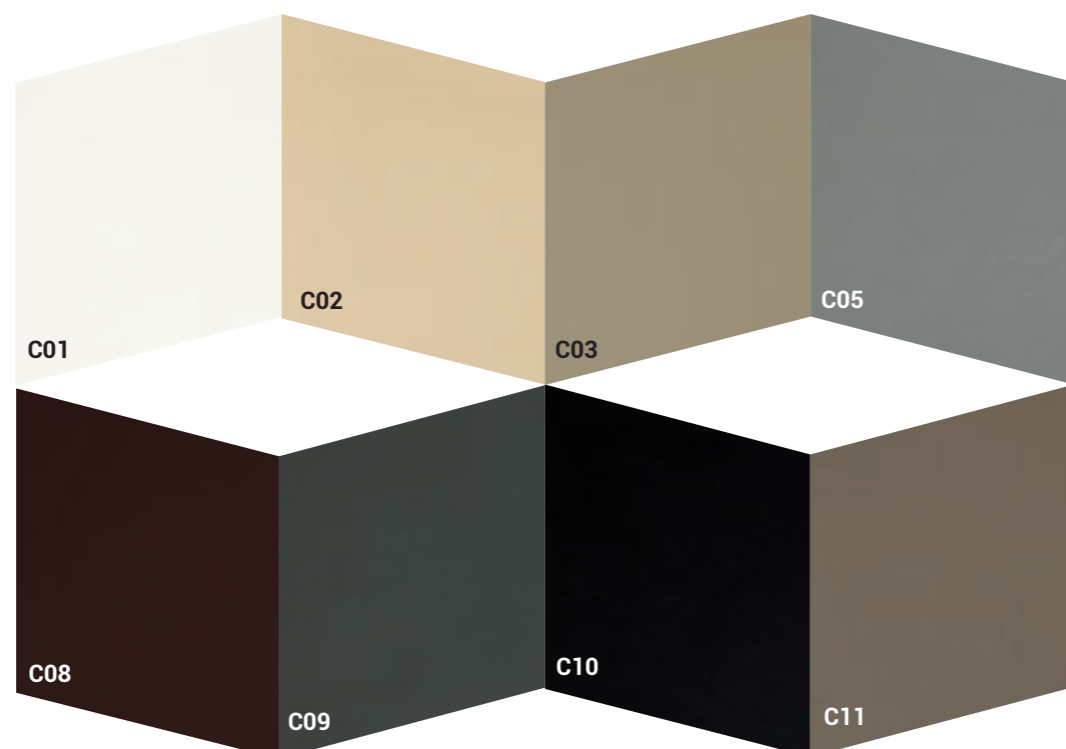

### POLIPROPILENE / POLYPROPYLENE / POLYPROPYLENE

Y01	Bianco
Y02	Nero
Y03	Antracite
Y04	Argento
Y05	Tortora
Y06	Marrone

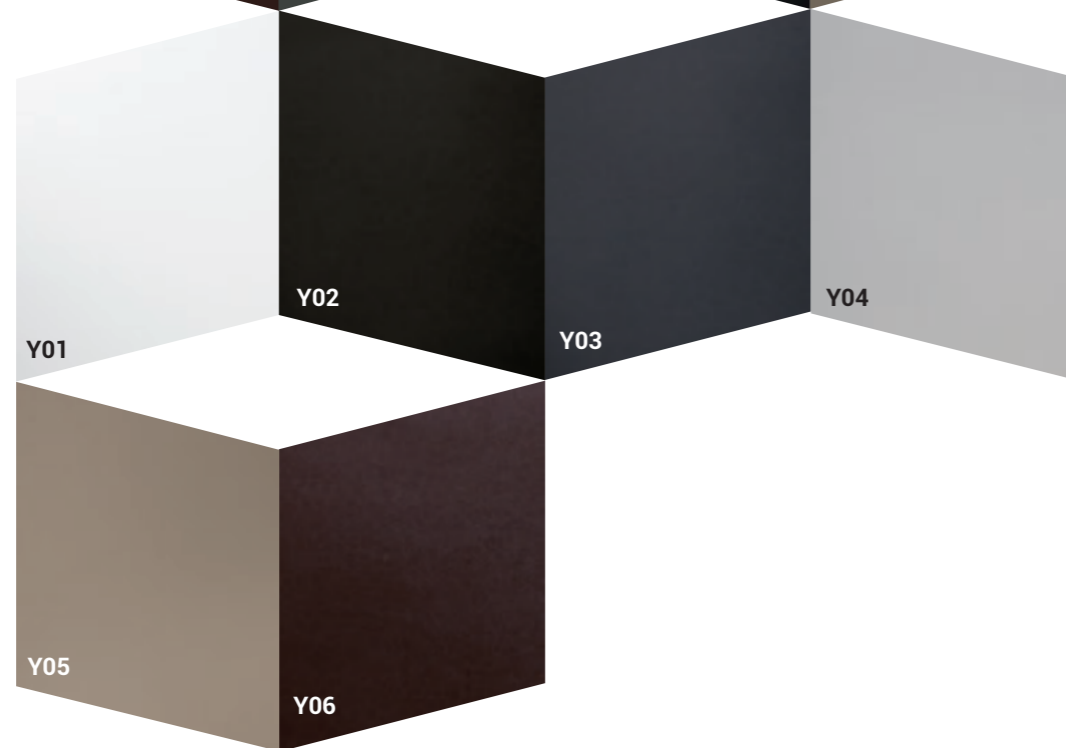

## FINITURE / FINITIONS / FINISHES

### PELLE / CUIR / LEATHER

P11	Nero
P15	Bianco ottico
P16	Sabbia
P17	Grafite

### ECOPELLE / ECO-CUIR / SOFT ECO-LEATHER

EC01	Bianco
EC37	Sabbia
EC62	Grafite
EC91	Nero

### ECOPELLE NABUK / ECO-CUIR NABUK / SOFT ECO-LEATHER NABUK

NB07	Grigio
NB17	Tortora
NB08	Bianco

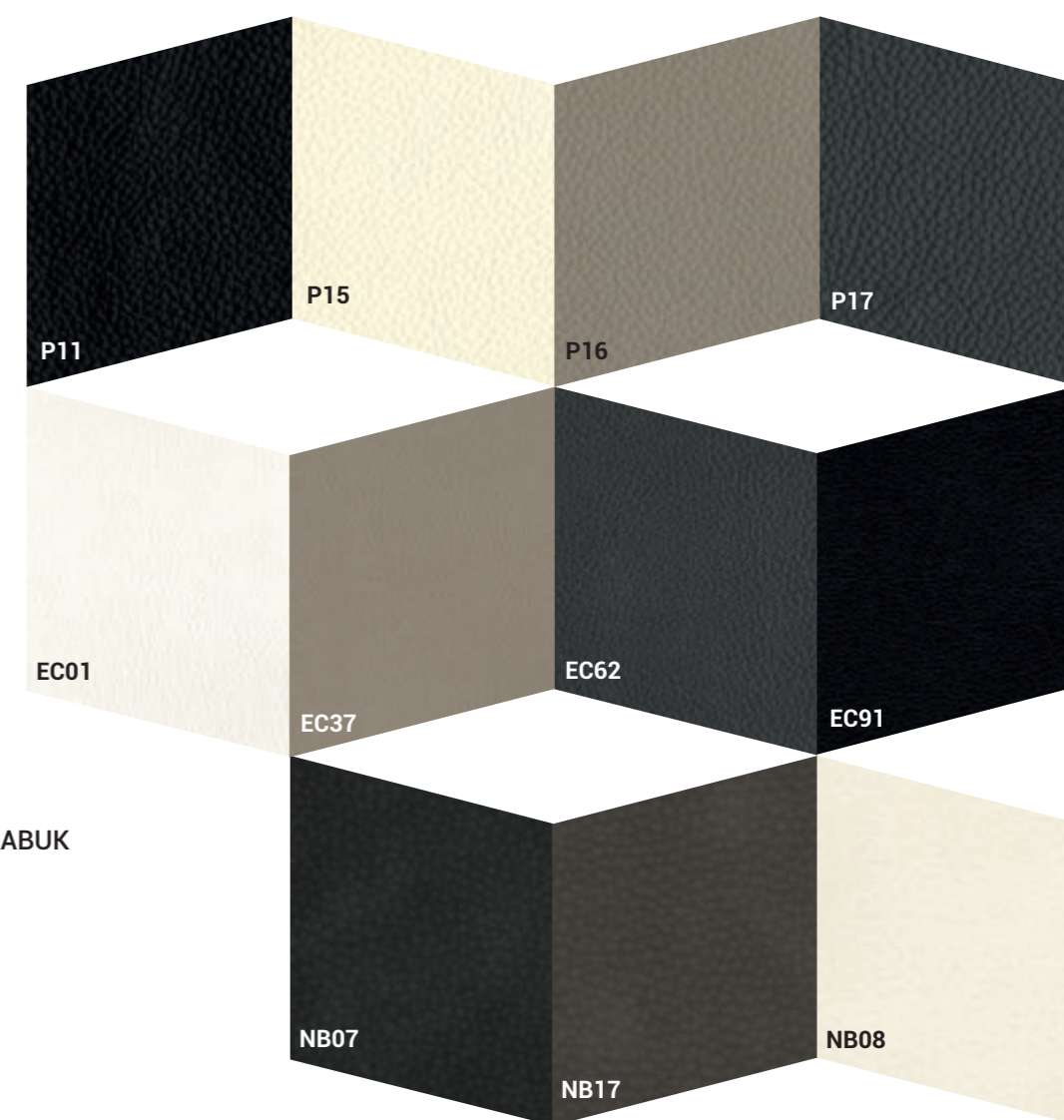

**AD:** regia\_comunicazione  
**Photo:** Studio Gabriotti  
**Stylist:** Carla Bernardis  
**Print:** Grafiche Antiga

**Thanks to:**  
D.Home  
Matteo Pala  
H & Co Home & Contract  
Vuzeta

---

Altacom srl è conforme ai requisiti di:  
ISO9001 / UNI EN ISO 9001:2015  
Certificato N.IT18/0167 - Sistema SGS

---

