

bodema®

the  
book —  
vol. 1



the  
book——  
vol<sub>1</sub>

---

# in dex

## 01

**FATTO IN ITALIA**  
— *made in italy*

- 06 STORIA  
*history*
- 08 FILOSOFIA  
*philosophy*
- 10 SHOWROOM  
*showroom*

## 02

**PRODUZIONE**  
— *production*

- 14 LAVORAZIONI  
*production*
- 16 CUCITURE  
*details*
- 18 QUALITÀ  
*quality control*

## 03

**DIVANI**  
— *sofas*

- 22 BLAKE
- 40 DALLAS
- 50 KYOTO
- 54 LONDON
- 60 MUCH MORE
- 68 MANHATTAN
- 72 TOKYO
- 78 SHANGHAI
- 90 BARCLAY
- 98 MR FLOYD
- 104 DOUGLAS
- 110 È TIME
- 118 ANYWAY
- 124 QUENTIN
- 128 BURANO
- 132 MURANO

## 04

**POLTRONE**  
— *armchairs*

- 138 CAROL
- 142 INGRID
- 146 KIM
- 148 NICOLE
- 150 OLEANDRA
- 152 GRACE
- 154 LU'
- 156 MARILYN
- 158 HAVANA
- 160 HAVANA LOUNGE
- 162 HAVANA SMALL
- 164 NINA
- 166 MARYANNE LOUNGE
- 168 DOVEVUOI

## 05

**TAVOLI E SEDIE**  
— *tables and chairs*

- 172 BLAKE
- 178 CI
- 182 MONICA
- 184 PEGGY

## 06

**CONTENITORI**  
— *storage*

- 188 PROFILE

## 07

**COMPLEMENTI**  
— *complements*

- 198 BLAKE LOW TABLE
- 202 CI LOW TABLE
- 204 BLUNT
- 208 CHIO
- 210 CINQUANTA
- 214 BIPEDE
- 216 CLESSIDRA
- 218 PONTE
- 220 SIEVE
- 222 SUMO
- 224 BUTTON

## 08

**CUSCINI**  
— *cushions*

- 226 TYPE AND SIZE

**TAPPETI**  
— *rugs*

- 232 LAND
- 236 WATER

## 09

**LETTI**  
— *beds*

- 242 SOPHIE
- 248 DALLAS
- 254 TOKYO
- 260 AURORE
- 266 HARRY
- 272 MEGAN
- 280 NEW ALICANTE
- 284 VIOLET
- 290 TIFFANY
- 294 LULU'

## 10

**INFO TECNICHE**  
— *technical info*

- 300 BASE CONTENITORE  
*storage base*
- 302 FINITURE  
*finishes*
- 305 DISEGNI TECNICI  
*technical drawings*

---

made  
in  
Italy

01



# HISTORY

— THE MEANING OF ROOTS, THE OPENING UP TO THE WORLD

Il senso delle radici, l'apertura al mondo. Nella dimensione globale dei mercati e delle idee, le radici sono un bene prezioso. Il fil rouge di una storia che inizia negli anni '60 del secolo scorso. L'avventura di una famiglia e di un'impresa tutta italiana. È l'epoca del boom economico e il design Made in Italy vive un momento di grande fervore. In una piccola fabbrica nel cuore della Brianza si lavora a ritmi serrati. Lo stabilimento sorge nel distretto di Meda, famoso da sempre per gli imbottiti e per l'abilità dei suoi artigiani tappezzeri. Uno di loro, Giulio De Mango, aveva aperto già un decennio prima la sua impresa. Esordi da terzista e poi, fra i pionieri di un settore in via di espansione, il lancio del proprio marchio: Bodema. Da quasi 50 anni un'azienda a conduzione familiare, oggi alla seconda generazione. Un percorso in evoluzione, aperto agli scenari internazionali. È un modo inconfondibile, fin da allora, di pensare e costruire divani, poltrone, letti e trasformabili.

The meaning of roots, the opening to the world. In the global dimension of the markets and ideas, roots are a valuable asset. The fil rouge of a history that begins in the latest 60s of the last century. The adventure of a family and a full Italian business. It is the time of the economic booming and the Made in Italy design experiences a moment of great fervour. In a small factory in the heart of Brianza they are working at lightning speed. The plant is located in Meda district, forever famous for upholstered products and for the skill of its craftsmen upholsterers. One of them, Giulio De Mango, had already opened a decade before his company. He started as a contractor and then, among the pioneers of a sector in growing expansion, he launched his own brand: Bodema. For nearly 50 years a family business, today in its second generation. An evolving path, open up to international scenarios. And a unique way, since then, to think and build sofas, armchairs, beds and sofasbeds.

Das Gefühl von seinen eigenen Wurzeln zu haben und Weltoffenheit zu leben. In der globalen Dimension von Märkten und Ideen sind eigene Wurzeln ein kostbares Gut. Der rote Faden einer Geschichte, die in den 60er Jahren des letzten Jahrhunderts beginnt. Das Abenteuer einer Familie und eines rein italienischen Unternehmens. Es ist die Epoche des wirtschaftlichen Aufschwungs und das, Made in Italy' und italienisches Design erlebt einen großen Erfolg. In einer kleinen Fabrik im Herzen von Brianza arbeitet man mit engen Zeitrahmen. Die Fabrik befindet sich im Bezirk von Meda, der schon immer für seine gepolsterte Möbel und für die Fähigkeit seiner Kunsthandwerker berühmt ist. Einer von ihnen, Giulio De Mango, hatte sein Geschäft vor zehn Jahren eröffnet. Als Drittunternehmer zuerst und dann als einer der Pioniere einer expandierenden Branche, die Einführung seiner eigenen Marke: Bodema. Seit fast 50 Jahren ein Familienbetrieb, heute in der zweiten Generation. Ein sich entwickelnder Weg, offen für internationale Szenarien. Bekannt für seine einzigartige Art und Weise, Sofas, Sessel, Betten und Schlafsofas zu entwickeln und zu produzieren.

Le sens des racines, l'ouverture sur le monde. Dans la dimension mondiale des marchés et des idées, les racines sont un bien précieux. Le fil rouge d'une histoire qui commence dans les années 60 du siècle dernier. L'aventure d'une famille et d'une entreprise entièrement italienne. C'est l'époque du boom économique et le design Made in Italy vit un moment de grande ferveur. Dans une petite usine au cœur de la Brianza, on travaille à un rythme soutenu. L'usine est située dans le district de Meda, depuis toujours célèbre pour ses tapisseries et pour le savoir-faire de ses artisans tapissiers. L'un d'entre eux, Giulio De Mango, avait ouvert son entreprise une décennie auparavant. Il a commencé comme entrepreneur compte de tiers et puis, parmi les pionniers d'un secteur en expansion, le lancement de sa propre marque: Bodema. Depuis près de 50 ans, une entreprise familiale, maintenant dans la deuxième génération. Un chemin évolutif, ouvert aux scénarios internationaux. C'est depuis lors une façon indubitable de penser et de construire des canapés, des fauteuils, des lits et des sofas-lits.

Значение корней, открытие миру. В глобальном измерении рынков и идей - корни играют немаловажную роль. Наша история берет свое начало в конце 60-х годов прошлого века. Семейная компания и истинный итальянский бизнес. Это время экономического подъема и небывалых достижений в итальянском дизайне. На маленькой фабрике в самом центре региона Брианца кипела работа. Фабрика расположена в городке Меда, всемирно известном традициями производства мягкой мебели и талантливыми мастерами. Компания одного из них, Джулио Де Манго, существует уже 10 лет. На заре своей деятельности, компания Де Манго производила мебель для других компаний, но впоследствии в целях завоевания рынка, он запустил собственный бренд Bodema. На сегодняшний день, спустя более 50 лет, уже второе поколение ведет семейный бизнес. Эволюция компании позволила выйти на международные рынки. И с того момента начался уникальный путь производства диванов, кресел, кроватей и раскладной мебели.

根源的意义，对世界的开放性在市场和思潮的全球层面中，根源是一种宝贵的资产。公司历史始于上个世纪60年代，一路见证了意大利商业的振兴之旅。这是个经济蓬勃发展的时代，是意大利制造设计的充满激情的时刻。在布里安扎市中心的一家小工厂里，他们正快节奏得工作中。该工厂位于梅达地区，以软装家具和工匠室内装潢技术而闻名。其中之一佼佼者就是Giulio De Mango，他在公司成立前十年就已经从事这个行业了。他最初是一名承包商，然后，在这个不断扩大的行业先驱中，他推出了自己的品牌：Bodema。近50年来，家族企业已进入第二代，开启了一条向国际市场不断发展的道路。自创立以后，Bodema以一种独特的思维方式来设计和制造沙发、扶手椅、床和沙发床。

FATTO IN ITALIA  
— made in italy

1958 - ESPOSIZIONE ARTIGIANI  
MEDESI - MOSTRA PERMANENTE  
DELLE COLLEZIONI PROPOSTE DALLE  
AZIENDE PRODUTTRICI DI MEDA

1958 - MEDA MANUFACTURERS'  
PERMANENT SHOWROOM



# PHILOSOPHY

## — DEVELOPING TRENDS, INVENTING NEW CLASSICS

Elaborare tendenze, inventare nuovi classici. Dal micro territorio di Meda Bodema attinge fin dall'inizio la sua linfa vitale. Un saper fare e un senso della bellezza che ne alimentano la creatività. In azienda si elaborano tendenze che segnano nuovi stili dell'abitare. Colori, materiali, forme, funzioni. E una fascinazione per tutto ciò che è meccanismo e movimento; divani che mutano forma, che cambiano grazie a ingegnosi accorgimenti tecnologici. Sistemi di sedute dove la modularità trova sempre nuove soluzioni. Trasformabili che nobilitano l'idea di divano letto, da arredo di servizio a oggetto elegante e di carattere. Il design secondo Bodema è sofisticato, caldo, personale. Capace, attraverso ogni singolo progetto, di dire qualcosa di nuovo che resta nel tempo. Stimoli e idee nascono anche dalla collaborazione con affermati architetti e designers.

Developing trends, inventing new classics. From the micro area of Meda Bodema gets its lifeblood from the start. A know-how and a sense of beauty which feed its creativity. In the company they work out trends, which mark new home styles. Colours, materials, shapes, functions. And a fascination for all that is mechanism and motion. Sofas turn into different shapes and change thanks to ingenious technological tricks. Seating systems where modularity always finds new solutions. Convertible sofas that ennoble the idea of sofa bed, from service furniture to elegant and key-distinguishing object. Design according to Bodema is sophisticated, warm, personal. Capable, through every single project, to say something new that remains over time. Ideas coming out from the collaboration with successful architects and designers.

Trends entwickeln, neue Klassiker erfinden. Aus dem Mikrogebiet von Meda, zieht Bodema von Anfang an sein Lebenselixier. Ein Know-how und ein Gefühl der Schönheit, die Kreativität fördert. Im Unternehmen werden Trends entwickelt, die neue Lebensstile kennzeichnen. Farben, Materialien, Formen, Funktionen. Und eine Faszination für alles, was Mechanismus und Bewegung ist; Sofas, die ihre Form verändern, ändern sich dank ausgeklügelter technologischer Geräte. Sitzsysteme, bei denen Modularität immer neue Lösungen findet. Sofas die die Idee eines Schlafsofas veredeln, von Servicemöbel bis zu eleganten Objekten mit Charakter. Bodemas Design ist raffiniert, warm und persönlich. Jedes einzelne Projekt befähigt, etwas neu zu erzählen, das in der Zeit bleibt. Anregungen und Ideen entstehen auch aus der Zusammenarbeit mit Architekten und Designern.

Développer les tendances, inventer de nouveaux classiques. Du micro-territoire de Meda, Bodema tire sa force de vie dès le début. Un savoir-faire et un sens de la beauté qui nourrissent la créativité. Des tendances sont en train de se développer dans l'entreprise qui marquent de nouveaux modes de habiter. Couleurs, matériaux, formes, fonctions. Et une fascination pour tout ce qui est mécanisme et mouvement; canapés qui changent de forme, grâce à des dispositifs technologiques ingénieux. Des systèmes de sièges où la modularité trouve toujours de nouvelles solutions. Des convertibles qui ennoblissent l'idée d'un canapé-lit, depuis meubles de service maintenant objets élégants et avec caractère. Selon Bodema, le design est sophistiqué, chaleureux et personnel. Capable, à travers chaque projet, de dire quelque chose de nouveau qui reste dans le temps. Stimuli et idées naissent également de la collaboration avec des architectes et des designers établis.

Создание трендов, открытие новой классики. С первых дней Bodema черпает свою жизненную силу из маленького округа Меда. Ноу-хау и чувство красоты, которые питают креативность. Компания работает над трендами, которые формируют современный домашний стиль. Цвета, материалы, формы и функциональность. Своеобразная утонченность всего, что связано с механизмами и движением. Диваны приобретают различные формы и меняются благодаря технологической изобретательности. Модульность всегда находит новые решения в системах сидений. Диваны-трансформеры обновили идею диван-кровати, от служебной мебели до элегантного и выразительного предмета. Главные принципы дизайна Bodema — утонченность, тепло и индивидуальность. Это способность через каждый новый проект сказать что-то новое, то, что остается с течением времени. Новые стимулы и идеи рождаются в результате сотрудничества с архитекторами и дизайнерами.

发展趋势, 创造经典从梅达的微观领域, Bodema从一开始就把握住了脉搏: 蕴含创造力的专业知识和美感。公司引导新生活方式的趋势, 这涉及到新的家居风格、颜色、材料、形状、功能、以及对机械及其运动规律研制的激情。沙发由于巧妙的技术技巧可以有不同的形状和变化; 座椅系统的模块化新解决方案; 体现沙发床理念的可转换沙发。。从舒适的家具到新颖别致的物件。Bodema的设计是精致的、温暖的、个性的。通过每一个项目, Bodema能够表达新的内容, 通过与成功的建筑师和设计师合作, Bodema有了很多新想法。



# SHOWROOM

— SINCE 2012 A SHOWROOM OF 700 SQUARE METERS ON THE EDGE OF MEDA HAS BECOME A REFERENCE POINT FOR PLANNERS, CUSTOMERS, ARCHITECTS AND DESIGNERS

La capacità di cambiare ed essere se stessi. Mezzo secolo di design, ricerca, eccellenza made in Italy. 40 anni di partecipazione ininterrotta al Salone del Mobile a Milano. Dal 2012 uno showroom di 700 mq alle porte di Meda, diventato punto di riferimento per progettisti, committenti contract, architetti e designer. Suggestivo spazio industriale riqualificato, quinte d'acciaio, pannelli semoventi, luci teatrali. Un palcoscenico contemporaneo, dove l'azienda mette in scena le sue visioni dell'abitare, attraverso allestimenti che si rinnovano di continuo. La forza di Bodema è nel restare fedele ai propri valori, con la voglia di evolvere. Oggi cambiare e continuare ad avere successo significa pensare in un'ottica globale, dove l'Italia è uno dei mercati con cui relazionarsi insieme al resto del mondo. E in questa nuova prospettiva, partecipare alle fiere internazionali, curare la comunicazione, anticipare e adottare le nuove tecnologie è la strategia per crescere e continuare ad essere se stessi.

The ability to change and be yourself. Almost half a century of design, research, made in Italy excellence. 40 years of uninterrupted participation in the Milan Furniture Fair. Since 2012 a showroom of 700 square meters on the edge of Meda has become a reference point for planners, customers, architects and designers. Gentrified charming industrial space, steel scenes, self-propelled panels, theatrical lighting. A contemporary stage where the company plays out its visions of living, through layouts, which keep on renewing themselves. Bodema strength is to stand to its principles, with the desire to evolve. Today changing and remaining successful mean to think in a global perspective, where Italy is one of the markets to relate to together with the rest of the world. In this new prospect, attending international fairs, taking care of communication, anticipating and adopting new technologies are the strategy to grow and to continue to be yourself.

Die Fähigkeit, sich zu verändern und doch sich selbst treu zu sein. Ein halbes Jahrhundert Design, Forschung und Qualität made in Italy. 40 Jahre ununterbrochene Teilnahme am Salone del Mobile in Mailand. Seit 2012 ist ein 700 m<sup>2</sup> großer Showroom vor den Toren von Meda ein Bezugspunkt für Designer, Bauunternehmer, Architekten und Designer geworden. Der Charme von industrial Design, Stahlkonstruktionen, mobile Wände, Theaterlampen. Eine zeitgenössische Bühne, auf der das Unternehmen seine Visionen des Lebens durch ständig erneuerte Installationen inszeniert. Die Stärke von Bodema ist es, seinen eigenen Werten treu zu bleiben und die Lust sich ständig weiter zu entwickeln. Sich zu verändern und weiterhin erfolgreich zu sein, bedeutet heute, in einer globalen Perspektive zu denken, in der Italien einer der Märkte ist, die sich mit dem Rest der Welt verbinden. In dieser neuen Perspektive ist die Teilnahme an internationalen Messen, die Kommunikation, das Antizipieren und Anwenden neuer Technologien die Strategie, um zu wachsen und gleichzeitig wir selbst zu bleiben

La capacità di changer et être soi-même. Un demi-siècle de design, de recherche, d'excellence made in Italy. 40 ans de participation continue au Salone del Mobile de Milan. Depuis 2012, un showroom de 700 mètres carrés situé dans la banlieue de Meda est devenu un point d'appui pour les concepteurs, entrepreneurs, architectes et designers. Espace industriel évocateur réaménagé, les coulisses en acier, panneaux autopropulsés, lumières de théâtre. Une scène contemporaine, où l'entreprise met en scène ses visions du vivre, à travers des installations qui se renouvellent sans arrêt. La force de Bodema est de rester fidèle à ses valeurs, avec le désir d'évoluer. Aujourd'hui, changer et continuer à réussir signifie penser dans une perspective globale, où l'Italie est l'un des marchés avec lesquels établir des relations comme avec le reste du monde. Et dans cette nouvelle perspective, participer à des foires internationales, s'occuper de la communication, anticiper et adopter les nouvelles technologies est la stratégie pour grandir en restant soi-même.

Способность меняться и быть собой. Пол столетия дизайна и исследований и исключительное качество made in Italy. Сорок лет непрерывного участия на Миланской мебельной выставке. С 2012 года шоу-рум площадью более 700 квадратный метрв на окраине Меды стал ориентиром для проектировщиков, клиентов, архитекторов и дизайнеров. Запоминающееся перепланированное промышленное пространство со стальными декорациями, передвижными панелями и сценическим освещением. Современная сцена, где компания воплощает свои представления о дизайне посредством экспозиций, которые постоянно обновляются. Сила Bodema в стремлении развиваться, придерживаясь своим принципам. На сегодняшний день меняться и оставаться успешным – означает думать в глобальной перспективе, это объединяет рынок Италии с рынками других стран. В этой новой перспективе, принятие участия в международных выставках, правильная коммуникация, прогнозирование и внедрение новых технологий - это стратегия роста и сохранения идентичности.

改变自我的能力 通过近半个世纪的设计和研 究，Bodema的意大利制造 渐入佳境。我们四十多年来 不间断地参加米兰家具展。 自2012年以来，在梅达有700 平方米的展厅，这成为规划师、 客户、建筑师和设计师的参观 点。这个展厅拥有优雅迷人的 工业空间，钢制场景，自行 式面板，舞台灯光。在这样一 个现代化的平台上，公司通 过布局展现其生活愿景，不断 更新自己。Bodema的力量是 坚持它的原则，不断变革。今 天，Bodema从全球的角度去 思考，把意大利与世界其它地 区的市场不断联系在一起，不 断改变自我、追求发展。在这 个新的前景下，Bodema不断参 加国际博览会，时刻关注交流， 采用新技术。这些是Bodema 不断成长和发展自我的战略。



---

# production



# 02



# TAILORING

— DIFFERENCES THAT MAKE OUR FURNITURE  
SOMETHING UNIQUE

Da un atelier del design, il calore di pezzi unici. Il piacere di rilassarsi sulla propria poltrona o divano preferito, di avvertirne l'originalità e il calore. Una particolare variante costruttiva o nelle dimensioni. Una cucitura insolita e un'imbottitura più ricca. Un colore selezionato fra infinite, possibili sfumature. Differenze a volte impercettibili che fanno di quel pezzo qualcosa di unico. Una forma ancora più accogliente e confortevole. Perché Bodema concepisce il design anche come attento lavoro sartoriale sui dettagli. L'azienda si è mantenuta volutamente di dimensioni flessibili per poter essere sempre agile, propositiva, pronta a incontrare le richieste e i desideri individuali. Le sue produzioni di serie hanno il carattere inimitabile dell'intervento manuale.

From a design atelier, the warmth of unique pieces. The pleasure of relaxing on your favorite armchair or sofa, of feeling its originality and warmth. A particular variation in the construction or in sizes. An unusual stitching and a richer padding. A colour selected among endless possible nuances. Differences, which may be sometimes imperceptible, but which make that piece something unique. An even more welcoming and comfortable shape. Because Bodema conceives design also as a careful tailoring job on details. The company has deliberately kept a flexible family size to be always prompt proactive, open to meet individual requirements. Its standard product range has inimitable character of manual intervention.

Aus einem Designstudio, die Wärme und Behaglichkeit einzelner Unikate. Das Vergnügen, sich auf Ihrem Lieblingssessel oder Sofa zu entspannen, um seine Ursprünglichkeit und Wärme zu spüren. Eine besondere konstruktive Variante oder spezielle Maße. Eine ungewöhnliche Naht und dickere Polsterung. Eine Farbe, die aus unendlich vielen möglichen Nuancen ausgewählt wird. Unterschiede, die manchmal nicht wahrgenommen werden können, machen das Stück einzigartig. Eine noch gemütlichere und bequemere Form. Denn Bodema versteht Design auch als sorgfältige Detailarbeit. Das Unternehmen ist wesentlich flexibel in seiner Größe geblieben, um immer beweglich und proaktiv zu sein, und auf Anforderungen und individuelle Wünsche eingehen zu können. Seine Serienproduktionen haben den unnachahmlichen Charakter manuell gefertigter Ware.

D'un studio de design, la chaleur de pièces uniques. Le plaisir de se détendre sur son fauteuil ou canapé préféré, pour sentir son originalité et sa chaleur. Une variante constructive ou en dimensions. Une couture inhabituelle et un rembourrage plus riche. Une couleur choisie parmi une infinité de nuances possibles. Des différences parfois imperceptibles font de cette pièce un objet unique. Une forme encore plus accueillante et confortable. Parce que Bodema conçoit le design également comme un travail de personnalisation minutieux. La société a délibérément gardé une taille flexible pour rester toujours agile, proactive, prête à répondre aux demandes et souhaits individuels. Ses productions en série ont le caractère inimitable de l'intervention manuelle.

Работа по принципу дизайн-ателье создает тепло уникальных вещей. Удовольствие отдыха на любимом кресле или диване, чувство его оригинальности и уюта. Выразительность конструкций и размеров. Необычная прошивка и эксклюзивная обивка. Выбранный цвет среди бесконечного множества вариаций. Различия, на первый взгляд незаметные, которые делают предмет уникальным. Более располагающая и комфортная форма. Потому что Bodema рассматривает дизайн как бережное внимание к деталям. Компания намеренно придерживается гибкого подхода, чтобы всегда быть быстрой, инициативной, готовой удовлетворить индивидуальные требования и пожелания. Его серийные продукты имеют неподражаемый характер ручного прикосновения.

从设计工作室，到独特的温暖的作品。在您最喜欢的扶手椅或沙发上放松身心，感受它的独创性和温暖、结构或尺寸的特定制定变化、不寻常的接缝和更丰富的填充物。差异有时难以察觉，Bodema从细微差别中精挑细选色彩，赋予这件作品独特性，使它更加温馨舒适和更受欢迎。Bodema还将设计视为细节上的精心剪裁。Bodema生产灵活性高、生产积极性高、生产质量高，可随时满足个人的要求和愿望，其标准产品系列生产具有很强的人工监督和管控性的特点。



# DETAILS

— MANUFACTURED WITH PASSION  
FOR THE BEAUTY OF THE MATERIALS AND DESIGN

Mani che cuciono e rifiniscono il tessuto e la pelle, lavorano il legno, assemblano i telai in acciaio. Gestì e pensieri di chi si impegna nella costante ricerca del nuovo e costruisce, giorno dopo giorno, una qualità made in Italy al 100%. Persone che condividono il legame con un territorio dove i mobili si fanno da sempre. Con una comune passione per la bellezza dei materiali, la coerenza del disegno, la precisione nell'esecuzione. E un'attenzione all'affidabilità nel tempo, all'ergonomia e al comfort. Qualità, soprattutto, è seguire il nascere e realizzarsi di ogni prodotto in tutte le sue fasi. Per proporre soluzioni che uniscono solidità e stile a un costo intelligente, in Italia e nel mondo.

Skilled hands to stitch fabric and leather, to work the wood, to assemble steel frames. Talent of people who steadily search for something original, day after day, to arrange 100% made in Italy high standards. People who share the link to a territory where furniture is a part of own culture. Everything always manufactured with passion for the beauty of the materials and perfection in the finishing; special care to reliability to ergonomics and to comfort. Quality means to follow every single step in all the manufacturing stages to propose solutions of strength and style at reasonable price, in Italy and worldwide

Hände, die unermülich nähen, Stoffe und Leder verfeinern, Holz und Metall bearbeiten, und so ein Zeichen setzen dafür, ständig auf der Suche nach Neuem zu sein, um 100% Qualität 'made in Italy' zu liefern. Menschen, die jeden Tag aufs Neue durch ihre Arbeit die Kultur der italienischen Möbelmanufaktur beweisen. Menschen die durch ihre gemeinsame Leidenschaft für Schönheit, Kohärenz in der Gestaltung und Präzision in der Ausführung erschaffen, und zudem auf Zuverlässigkeit, Ergonomie und Komfort achten. Qualität bedeutet, auf das Produkt in allen Produktions-Phasen zu achten, und immer Lösungen zu suchen, die Solidität und Stil mit konkurrenzfähigen Preisen anstreben, in Italien und in der ganzen Welt.

Des mains qui cousent et finissent le tissu et le cuir, travaillent le bois, assemblent les cadres en acier. Les signes et les pensées de ceux qui s'engagent dans la recherche constante de quelque chose d'original, jour après jour, et toujours fait en Italie à 100%. Les personnes qui partagent la liaison avec un territoire où les meubles sont une partie de sa propre culture. Ils sont toujours fabriqués avec passion pour la beauté des matériaux et le design, parfait dans leurs finitions; un soin particulier est apporté à la fiabilité, l'ergonomie et le confort. La qualité, principalement, est surveillée à chaque étape de la fabrication, dans toute la production, pour proposer des solutions qui combinent la force et le style.

Качество рождается благодаря рукам, которые шьют и отделывают ткани и кожу, обрабатывают дерево и собирают стальные элементы. Благодаря мыслям и действиям тех, кто находится в постоянном поиске нового и того, кто день за днем делает своими руками качество 100% made in Italy. Благодаря людям, глубоко связанным с территорией, на которой мебель делалась всегда; объединенным любовью к красоте материалов, к чистоте рисунка и к точности исполнения. Особое внимание уделяется надежности во времени, эргономике и комфорту. Залог качества – это, прежде всего, контроль производства каждого изделия на каждом этапе его изготовления. Все для того чтобы предложить покупателю в Италии и в мире продукцию, которая объединяет в себе качество и стиль при разумных ценах.

熟练的工匠用手工缝制布料和皮革，用手工组装木头和钢框架，精益求精。Bodema的设计师不断地追求原创并遵循100%意大利制造的高标准。家具是我们文化的一部分，在这个领域的我们不断去分享它。我们始终对材料之美和精加工完美制造充满激情：特别注重人体工程学和舒适性、可靠性。对于质量把控方面，我们遵循所有生产阶段的每一步，严格监管品质。在意大利和全球范围的项目中，我们会在合理价格基础上给出有实力和有风格的解决方案。



# FLEXIBILITY AND QUALITY

— IMPECCABLE INTERPRETERS  
OF HIGHLY COMPLEX CONTRACT PROJECTS

Interpreti impeccabili di progetti contract ad alta complessità. L'identità di Bodema si esprime anche nel controllo di tutta la filiera produttiva. La padronanza di ogni fase permette di interpretare con grande flessibilità i progetti contract più complessi. Lavorando fianco a fianco con l'architetto che cura la commessa, l'azienda riesce a tradurre le sue idee in realtà. Il monitoraggio dell'intero processo permette a Bodema di pianificare con esattezza i tempi e i costi e di rispettarli con puntualità.

Impeccable interpreters of highly complex contract projects. Bodema identity is also expressed in the control of the entire production chain. The mastery of each phase allows great flexibility in interpreting the most complex contract projects. Working side by side with the architect who takes care of the order, the company is able to turn ideas to reality. The monitoring of the whole process allows Bodema to plan exactly time and costs and to respect them.

Tadellose Dolmetscher hochkomplexer Vertragsprojekte. Die Identität von Bodema drückt sich auch in der Kontrolle der gesamten Produktionskette aus. Die Beherrschung jeder Produktionsphase erlaubt es, die komplexesten Vertragsprojekte mit großer Flexibilität zu interpretieren. Gemeinsam mit dem Architekten, der sich um die Arbeit kümmert, gelingt es dem Unternehmen, seine Ideen in die Realität umzusetzen. Durch die Überwachung des gesamten Prozesses kann Bodema Zeit und Kosten genau planen und rechtzeitig einhalten.

Interprètes impeccables de projets contractuels très complexes. L'identité de Bodema s'exprime également dans le contrôle de toute la chaîne de production. La maîtrise de chaque phase permet d'interpréter avec une grande souplesse les projets contractuels les plus complexes. Travaillant côte à côte avec l'architecte en charge du travail, l'entreprise parvient à traduire ses idées en réalité. Le suivi de l'ensemble du processus permet à Bodema de planifier ses coûts et son temps avec précision et de les respecter à temps.

Безупречная интерпретация очень сложных контрактных проектов. Индивидуальность Bodema также выражается в полном контроле над всей цепочкой производства. Мастерство каждого этапа дает большую гибкость в интерпретации самых сложных контрактных проектов. Работая бок и бок с архитектором, компания воплощает его идеи в реальность. Мониторинг всего процесса позволяет Bodema точно планировать время и затраты и своевременно их соблюдать.

高度复杂的落地项目,无可挑剔的解决者。Bodema的同一性表现在对整个生产链的控制上。我们掌握每个生产阶段的过程并且可以非常灵活地解决最复杂的项目落地。我们与负责订单的建筑师并肩工作,公司能够将其想法变为现实。通过监控整个流程, Bodema可以准确地计划时间和成本,更好的完成合同项目。



LES AIGLONS, CHAMONIX



IZAKAYA RESTAURANT, MILANO



RESORT COLLINA D'ORO, AGRÀ



RESORT COLLINA D'ORO, AGRÀ



LES AIGLONS, CHAMONIX



RESORT COLLINA D'ORO, AGRÀ



FIREFLY POOL, ZERMATT



LES AIGLONS, CHAMONIX



STUDI TELEVISIONI MEDIASET, COLOGNO MONZESE

---

so  
fas

03



**BLAKE**

DESIGN  
ADRIANO  
CASTIGLIONI  
2019



DIVANI  
— sofas

divano — sofa  
BLAKE  
poltrona — armchair  
MARYANNE LOUNGE

tavolini — low tables  
BLAKE  
madie — storage  
PROFILE



DIVANI  
— sofas

divano — sofa  
BLAKE  
poltrona — armchair  
INGRID

tavolini — low tables  
CINQUANTA



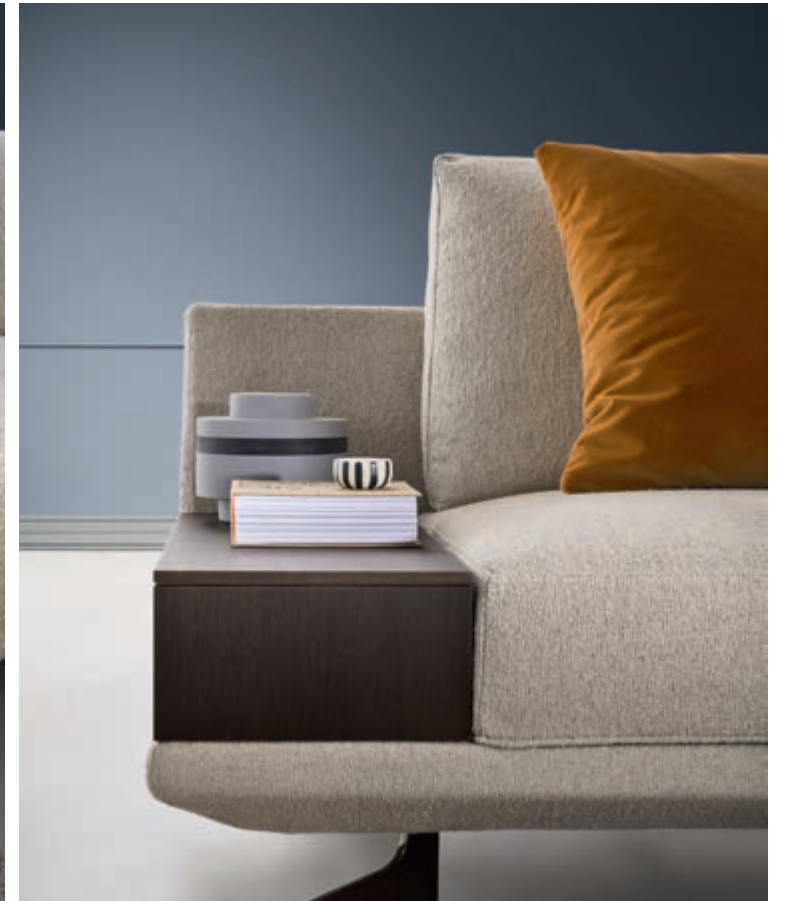





DIVANI  
— sofas

divano — sofa  
BLAKE  
poltrona — armchair  
KIM

tavolini — low tables  
BLAKE  
CI







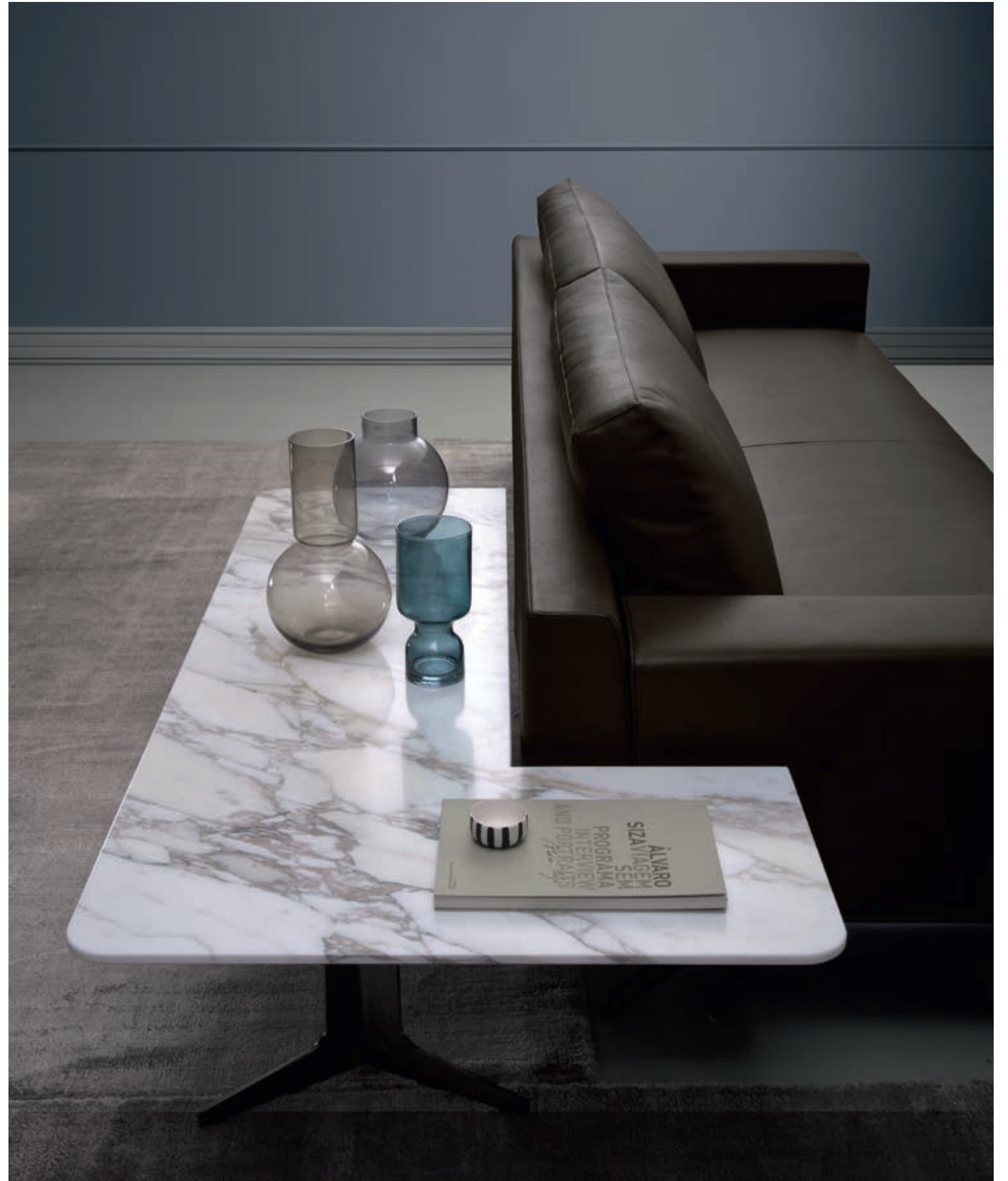

## DALLAS

DESIGN  
GIUSEPPE  
MANZONI  
2018



DIVANI  
— sofas

divano — sofa  
DALLAS  
poltrona — armchair  
CAROL  
pouf — ottoman  
SUMO

tavolini — low tables  
CINQUANTA



**DIVANI**  
— sofas

divano — sofa  
DALLAS

tavolini — low tables  
CINQUANTA  
CLESSIDRA

tappeto — rug  
LAND DOVE





DIVANI  
— sofas

divano — sofa  
DALLAS

tavolini — low tables  
CINQUANTA  
CI  
made — storage  
PROFILE



DIVANI  
— sofas

divano — sofa  
DALLAS  
poltrona — armchair  
OLEANDRA

tavolini — low tables  
CI  
madia — storage  
PROFILE

tappeto — rug  
LAND DOVE



## KYOTO

DESIGN  
GIUSEPPE  
MANZONI  
2018



DIVANI  
— sofas

divano — sofa  
KYOTO  
poltrona — armchair  
NINA

tavolini — low tables  
CINQUANTA  
CI  
madia — storage  
PROFILE

tappeto — rug  
LAND DOVE  
sedie — chairs  
MONICA



## LONDON

DESIGN  
GIUSEPPE  
MANZONI  
2017



DIVANI  
— sofas

divano — sofa  
LONDON  
poltrona — armchair  
MARILYN  
pouf — ottoman  
BUTTON

tavolini — low tables  
CI  
CHIO  
SIEVE



DIVANI  
— sofas

divano — sofa  
LONDON  
poltrona — armchair  
INGRID  
pouf — ottoman  
SUMO

sedie — chairs  
MONICA  
tavolini — low tables  
CINQUANTA  
tavoli — tables  
CI



## MUCH MORE

DESIGN  
ROBERTO PICELLO  
UMBERTO CIFARELLI  
2017





DIVANI  
— sofas

divano — sofa  
MUCH MORE  
poltrona — armchair  
MARILYN

tavolini — low tables  
CI  
SIEVE



DIVANI  
— sofas

divano — sofa  
MUCH MORE  
sedie — chairs  
MONICA

tavolini — low tables  
CINQUANTA  
tavolo — table  
CI



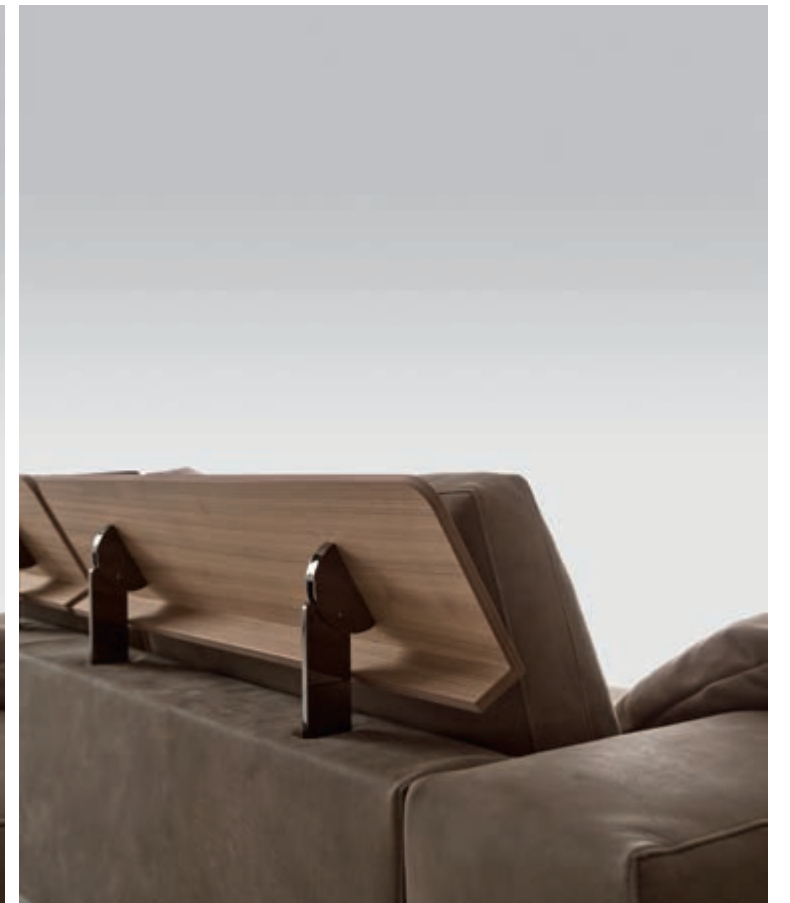

## MANHATTAN

DESIGN  
GIUSEPPE  
MANZONI  
2015



DIVANI  
— sofas

divano — sofa  
MANHATTAN  
poltrona — armchair  
MARILYN

tavolini — low tables  
CLESSIDRA

tappeto — rug  
WATER GREY



## TOKYO

DESIGN  
GIUSEPPE  
MANZONI  
2015









## SHANGHAI

DESIGN  
GIUSEPPE  
MANZONI  
2015



DIVANI  
— sofas

divano — sofa  
SHANGHAI  
poltrona — armchair  
NINA

tavolini — low tables  
BLAKE  
CI



DIVANI  
— sofas

divano — sofa  
SHANGHAI

tavolini — low tables  
CINQUANTA  
CI  
media — storage  
PROFILE





DIVANI  
— sofas

divano — sofa  
SHANGHAI  
poltrona — armchair  
NINA

tavolini — low tables  
CI



**DIVANI**  
— sofas

divano — sofa  
SHANGHAI  
poltrona — armchair  
NINA

tavolino — low table  
CI  
madia — storage  
PROFILE



DIVANI  
— sofas

divano — sofa  
BARCLAY

tavolini — low tables  
SIEVE

## BARCLAY

DESIGN  
GIUSEPPE  
MANZONI  
2014



DIVANI  
— sofas

divano — sofa  
BARCLAY  
poltrona — armchair  
NINA

tavolini — low tables  
CINQUANTA  
CI









## MR FLOYD

DESIGN  
GIUSEPPE  
MANZONI  
2012



DIVANI  
— sofas

divano — sofa  
MR FLOYD  
poltrona — armchair  
NINA

tavolini — low tables  
SIEVE



DIVANI  
— sofas

divano — sofa  
MR FLOYD  
poltrona — armchair  
MARYANNE LOUNGE  
sedie — chairs  
MONICA

tavolini — low tables  
CINQUANTA  
C1  
tavolo — table  
C1



## DOUGLAS

DESIGN  
GIUSEPPE  
MANZONI  
2014



DIVANI  
— sofas

divano — sofa  
DOUGLAS  
poltrona — armchair  
OLEANDRA  
sedia — chair  
MONICA

tavolini — low tables  
CINQUANTA  
console — console  
BLUNT







## È TIME

DESIGN  
ROBERTO PICELLO  
UMBERTO CIFARELLI  
2011



DIVANI  
— sofas

divano — sofa  
É TIME  
poltrona — armchair  
INGRID  
sedie — chairs  
MONICA

tavolini — low tables  
BIFEDE  
CINQUANTA  
tavolo — table  
CI





**DIVANI**  
— sofas

divano — sofa  
É TIME  
poltrona — armchair  
HAVANA LOUNGE  
sedie — chairs  
MONICA

tavolini — low tables  
SIEVE  
tavolo — table  
CI

tappeto — rug  
LAND DOVE



**ANYWAY**

DESIGN  
ADRIANO  
CASTIGLIONI  
2011



**DIVANI**  
— sofas

divano — sofa  
ANYWAY  
poltrona — armchair  
INGRID

tavolini — low tables  
CINQUANTA  
CI

tappeto — rug  
LAND DOVE





## QUENTIN

DESIGN  
GIUSEPPE  
MANZONI  
2012





DIVANI  
— sofas

divano — sofa  
QUENTIN  
poltrona — armchair  
NINA

tavolini — low tables  
BIFEDE  
PONTE



DIVANI  
— sofas

divano — sofa  
BURANO

tappeto — rug  
WATER GREY

## BURANO

DESIGN  
GIUSEPPE  
MANZONI  
2014



**DIVANI**  
— sofas

divano — sofa  
BURANO  
poltrona — armchair  
OLEANDRA

tavolini — low tables  
CLESSIDRA



## MURANO

DESIGN  
GIUSEPPE  
MANZONI  
2014



DIVANI  
— sofas

divano — sofa  
MURANO  
poltrona — armchair  
NINA

tavolini — low tables  
CLESSIDRA



---

# arm cha irs

# 04



# CAROL

DESIGN  
GIUSEPPE  
MANZONI  
2018



POLTRONE  
— *armchairs*

poltrona — *armchair*  
CAROL

tavolini — *low tables*  
CI  
console — *console*  
BLUNT



**POLTRONE**  
— *armchairs*

poltrona — *armchair*  
CAROL

tavolini — *low tables*  
CI

tappeto — *rug*  
LAND DOVE





**INGRID**

DESIGN  
GIUSEPPE  
MANZONI  
2018



**POLTRONE**  
— *armchairs*

poltrona — *armchair*  
INGRID

console — *console*  
BLUNT



**POLTRONE**  
— *armchairs*

poltrona — *armchair*  
KIM

tavolini — *low tables*  
CI

**KIM**  
DESIGN  
GIUSEPPE  
MANZONI  
2017



POLTRONE  
— armchairs

poltrona — armchair  
NICOLE

tavolini — low tables  
CLESSIDRA

## NICOLE

DESIGN  
GIUSEPPE  
MANZONI  
2017



# OLEANDRA

DESIGN  
GIUSEPPE  
MANZONI  
2016



POLTRONE  
— armchairs

poltrona — armchair  
GRACE

tavolino — low table  
CI

## GRACE

DESIGN  
GIUSEPPE  
MANZONI  
2016



**LÙ**  
DESIGN  
GIUSEPPE  
MANZONI  
2015



**POLTRONE**  
— *armchairs*

poltrona — *armchair*  
LÙ



**MARILYN**

DESIGN  
GIUSEPPE  
MANZONI  
2015





**POLTRONE**  
— *armchairs*

poltrona — *armchair*  
HAVANA

tavolini — *low tables*  
CI

tappeto — *rug*  
LAND DOVE

**HAVANA**

DESIGN  
GIUSEPPE  
MANZONI  
2014



## HAVANA LOUNGE

DESIGN  
GIUSEPPE  
MANZONI  
2014



POLTRONE  
— *armchairs*

poltrona — *armchair*  
HAVANA LOUNGE

tavolino — *low table*  
BIPEDA

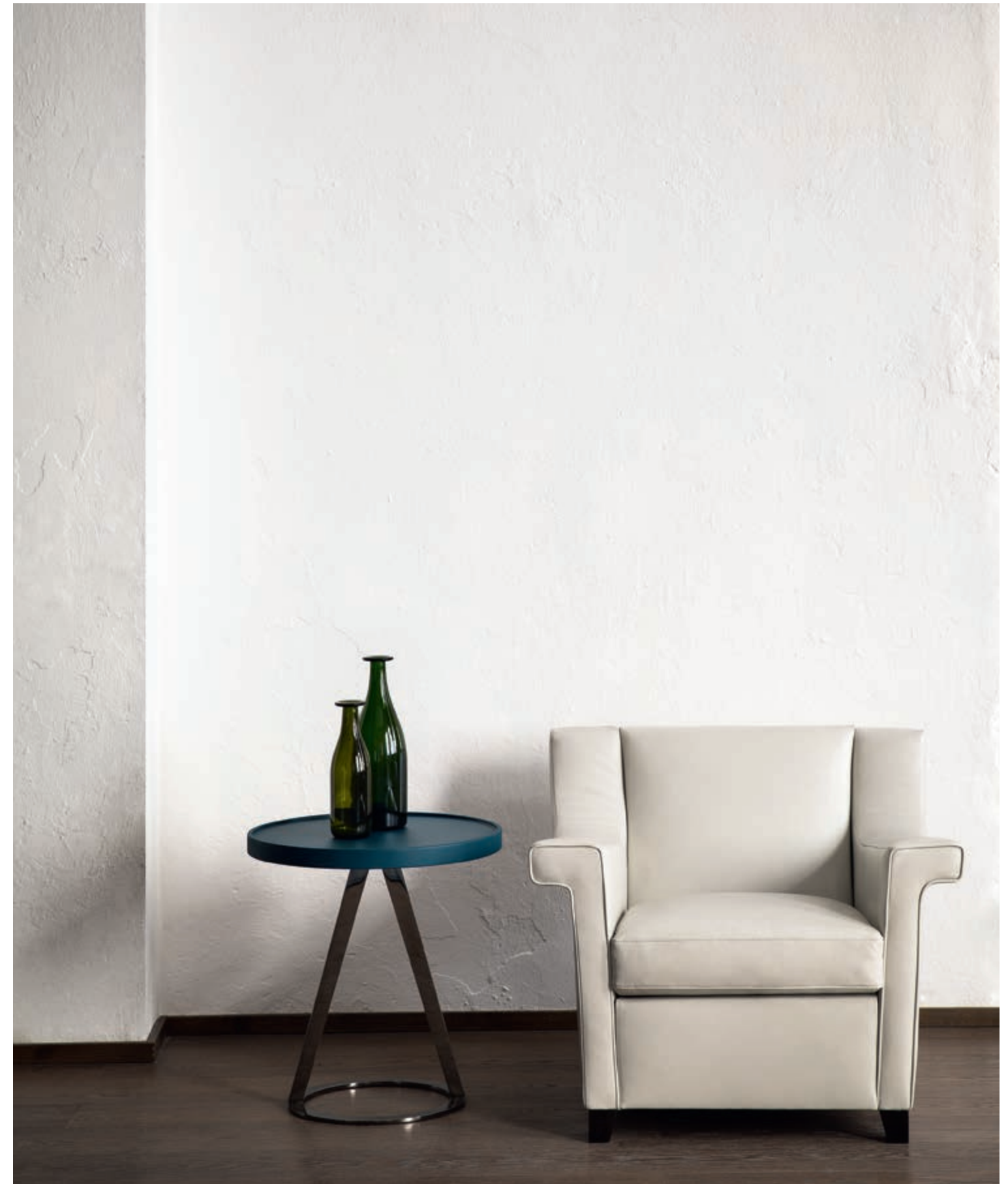

## HAVANA SMALL

DESIGN  
GIUSEPPE  
MANZONI  
2014



**NINA**  
DESIGN  
GIUSEPPE  
MANZONI  
2014



**POLTRONE**  
— *armchairs*

poltrona — *armchair*  
NINA

tavolino — *low table*  
CINQUANTA



## MARYANNE LOUNGE

DESIGN  
GIUSEPPE  
MANZONI  
2014



POLTRONE  
— armchairs

poltrona — armchair  
DOVEVUOI

tavolino — low table  
SIEVE

## DOVEVUOI

DESIGN  
STUDIO  
RES  
1990



---

# tables and chairs

05



## BLAKE TABLE

DESIGN  
ADRIANO  
CASTIGLIONI  
2019

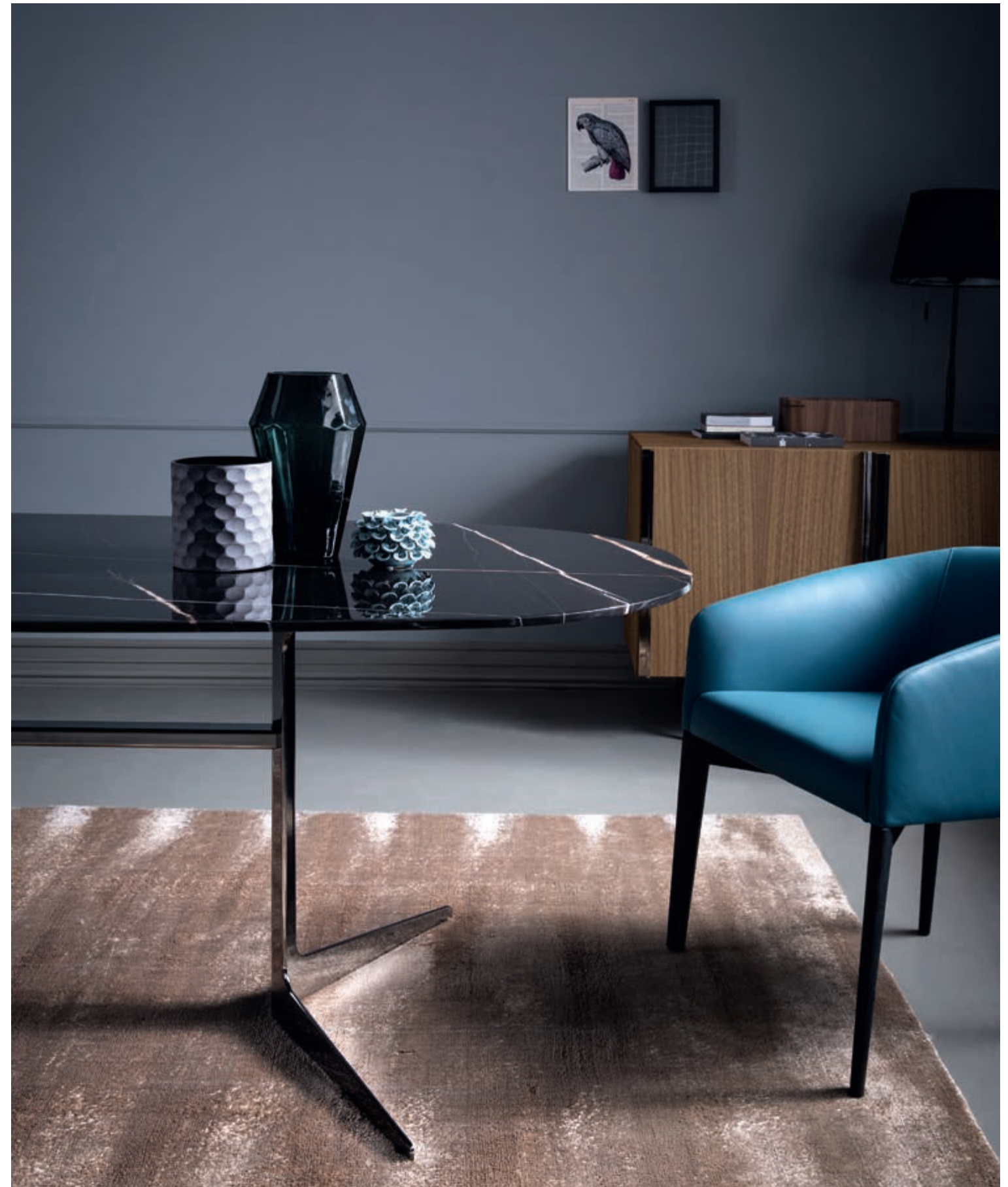



TAVOLI E SEDIE  
— tables and chairs

sedie — chairs  
PEGGY

tavolo — table  
BLAKE  
madia — storage  
PROFILE



TAVOLI E SEDIE  
— tables and chairs

sedie — chairs  
PEGGY

tavolo — table  
BLAKE  
madia — storage  
PROFILE

tappeto — rug  
LAND DOVE



**CI TABLE**

DESIGN  
CARLOTTA  
MANZONI  
2018

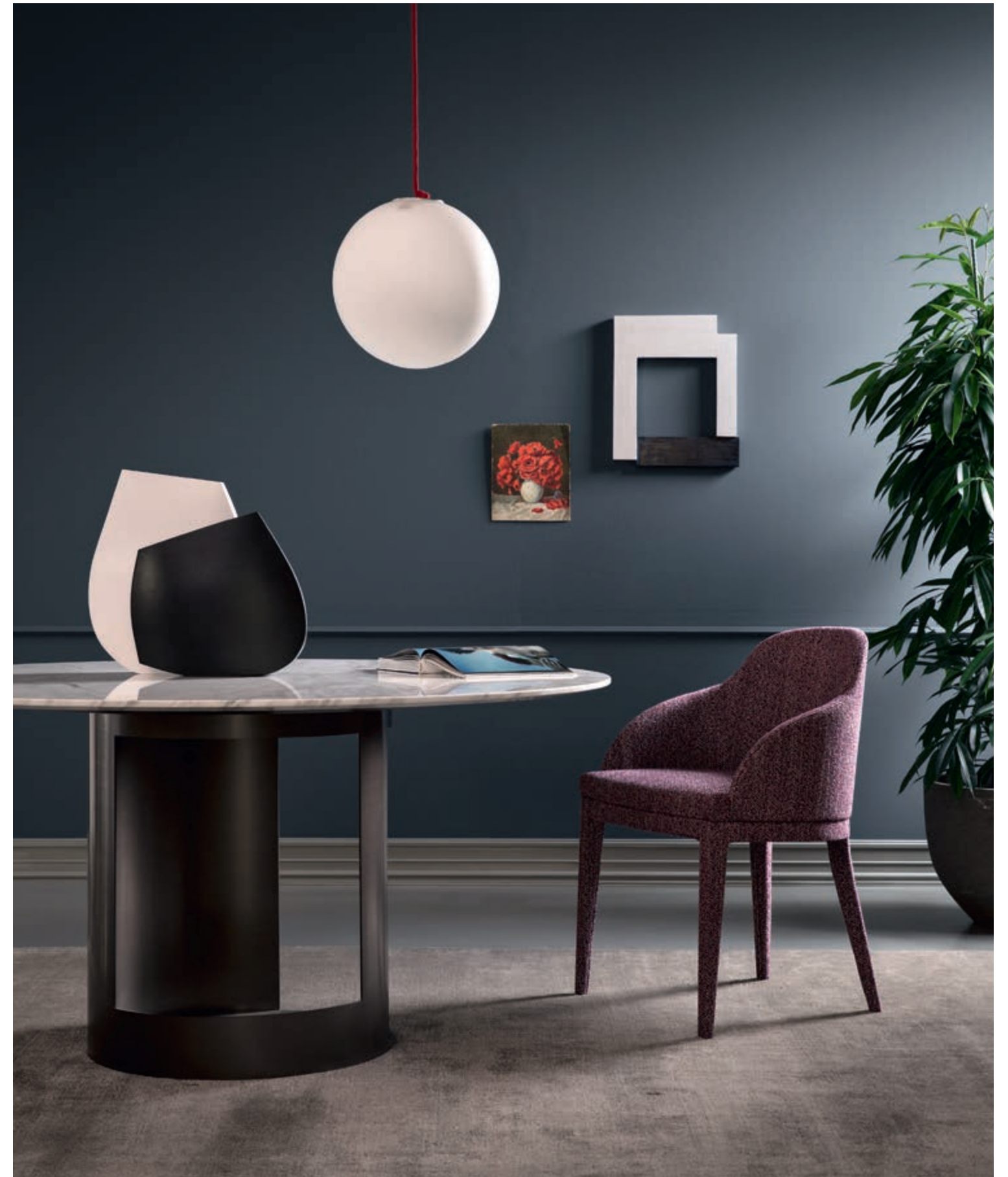

TAVOLI E SEDIE  
— tables and chairs

divano — sofa  
MUCH MORE  
sedia — chair  
MONICA

tavolo — table  
CI  
tavolino — low table  
SIEVE  
madia — storage  
PROFILE



**MONICA**

DESIGN  
GIUSEPPE  
MANZONI  
2018



**PEGGY**

DESIGN  
ADRIANO  
CASTIGLIONI  
2019

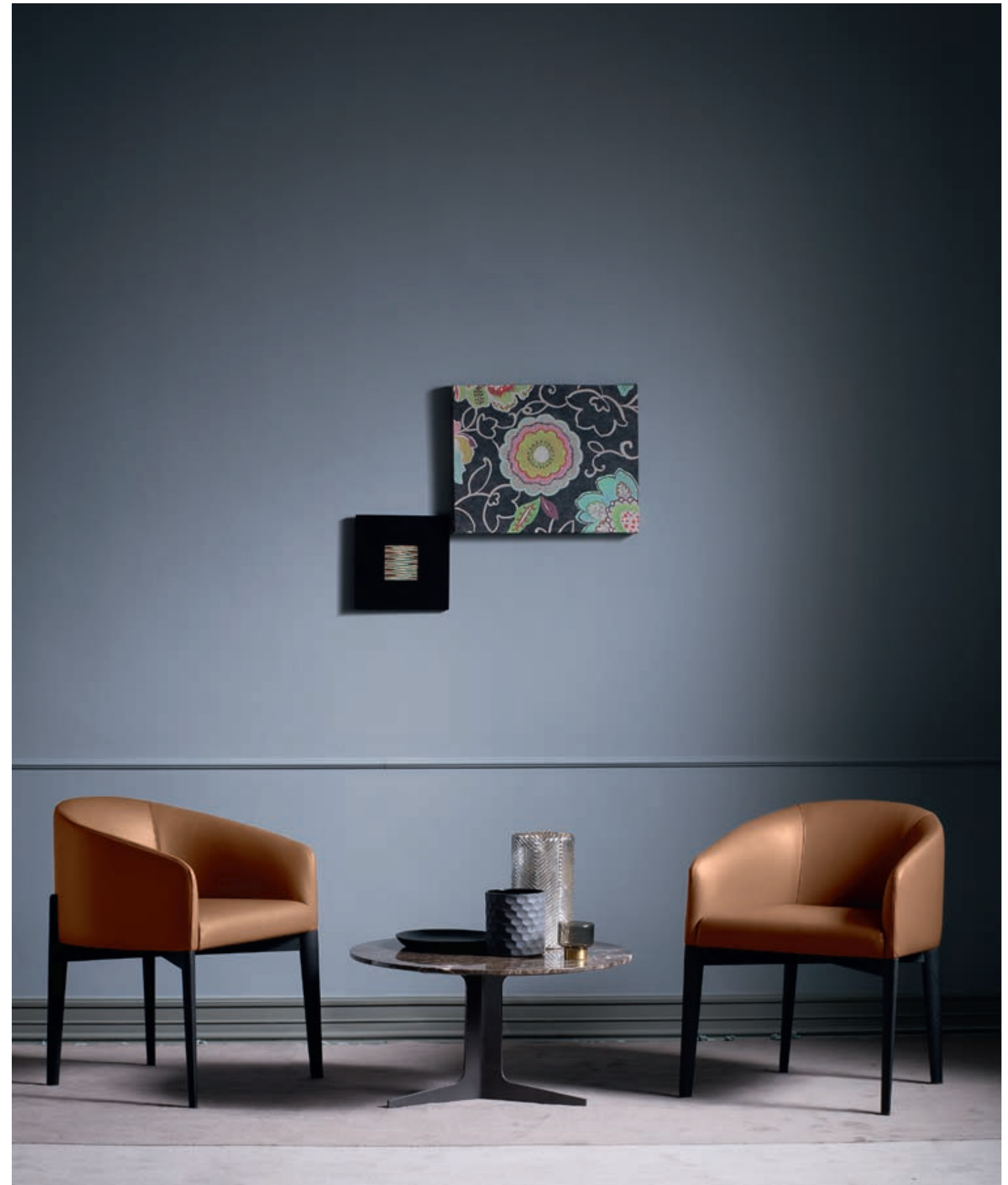

---

# sto ra ge

# 06



**PROFILE**

DESIGN  
GIUSEPPE MANZONI  
2019





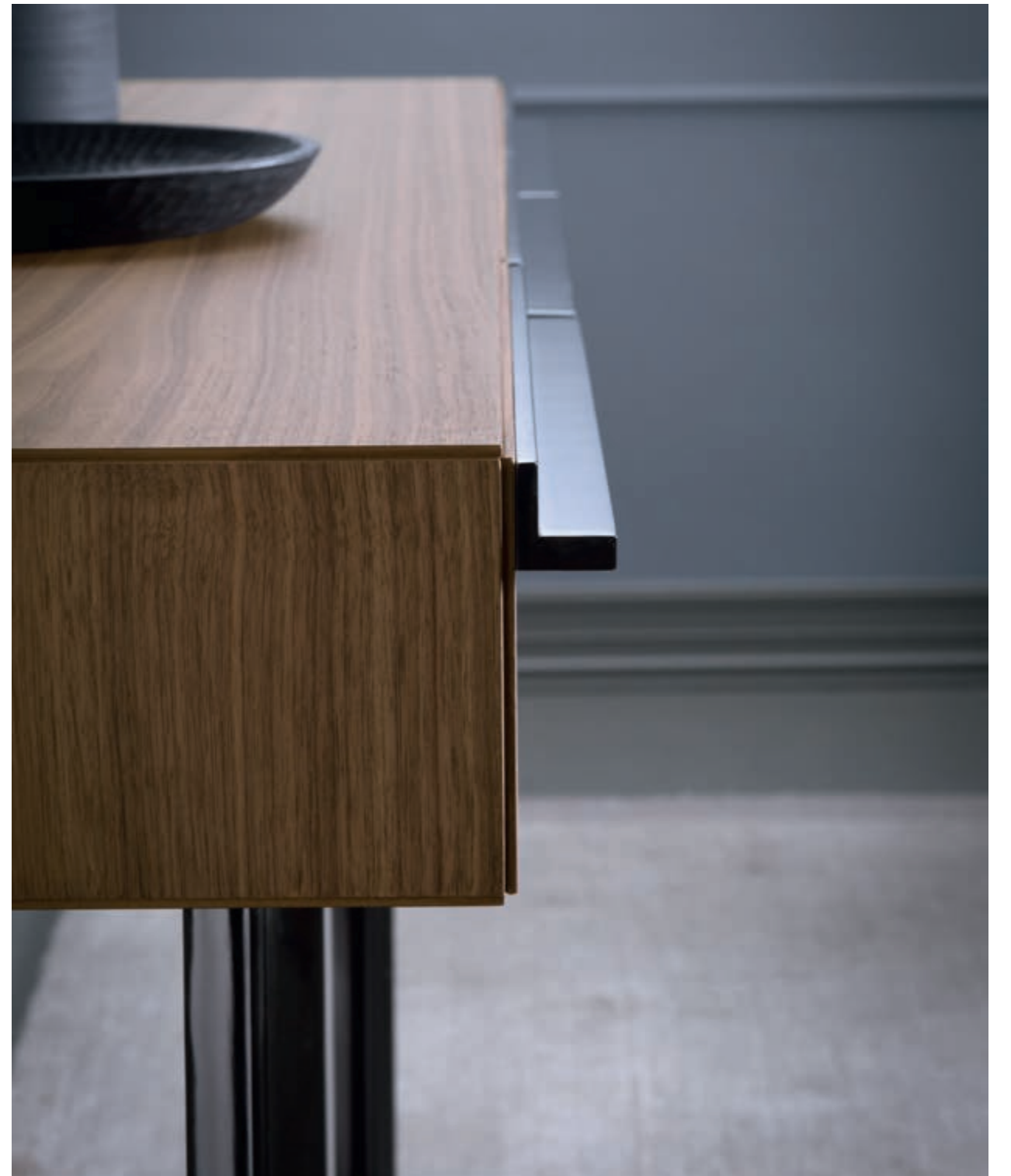





---

# comp lem ents

07

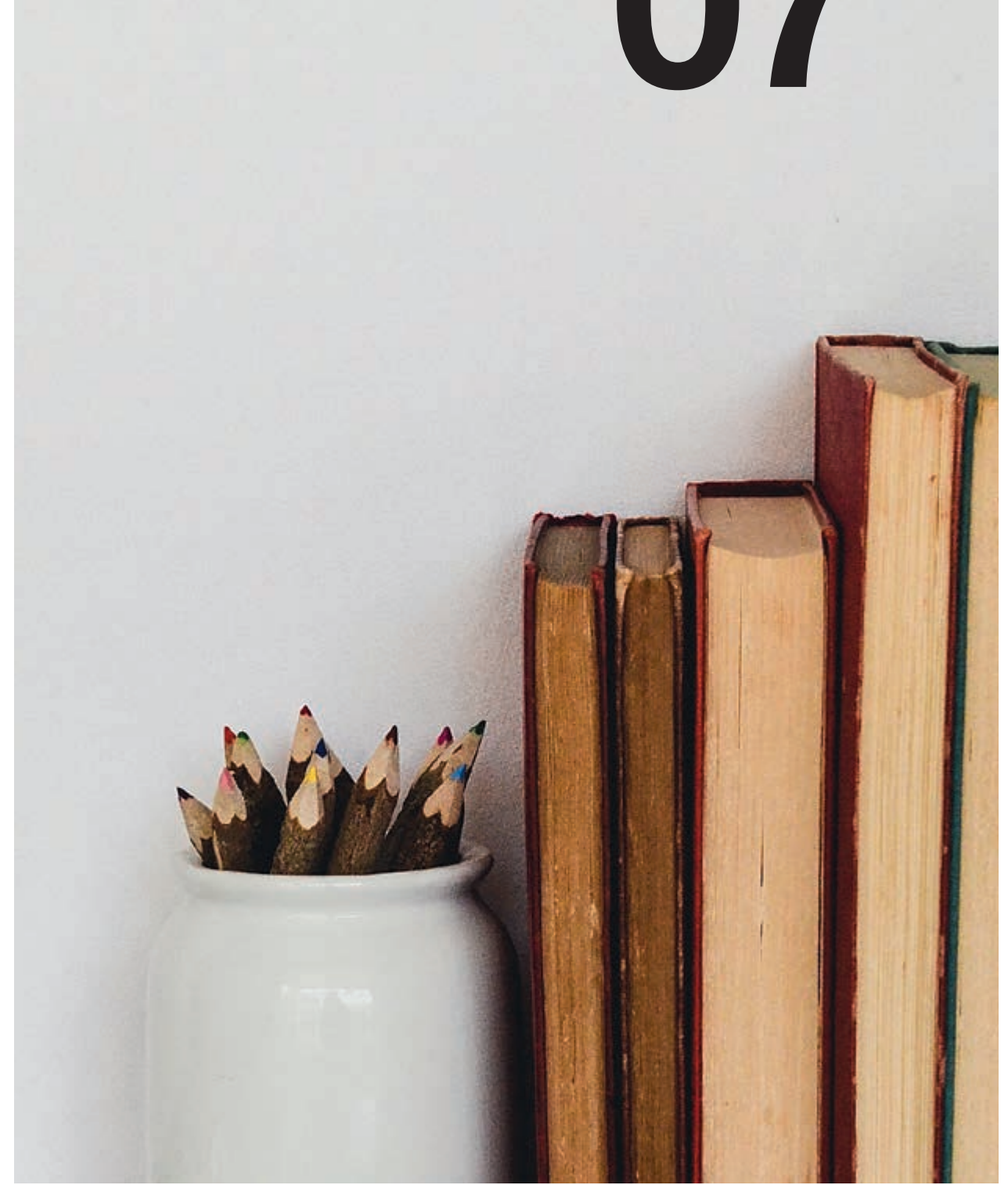

## BLAKE LOW TABLES

DESIGN  
ADRIANO  
CASTIGLIONI  
2019





COMPLEMENTI  
— complements

poltrona — armchair  
NINA

tavolini — low tables  
BLAKE



**CI LOW TABLE**

DESIGN  
CARLOTTA  
MANZONI  
2018



**BLUNT**

DESIGN  
GIUSEPPE  
MANZONI  
2018







**CHIO**  
DESIGN  
GIUSEPPE  
MANZONI  
2018



COMPLEMENTI  
— complements

tavolini — low tables  
CHIO

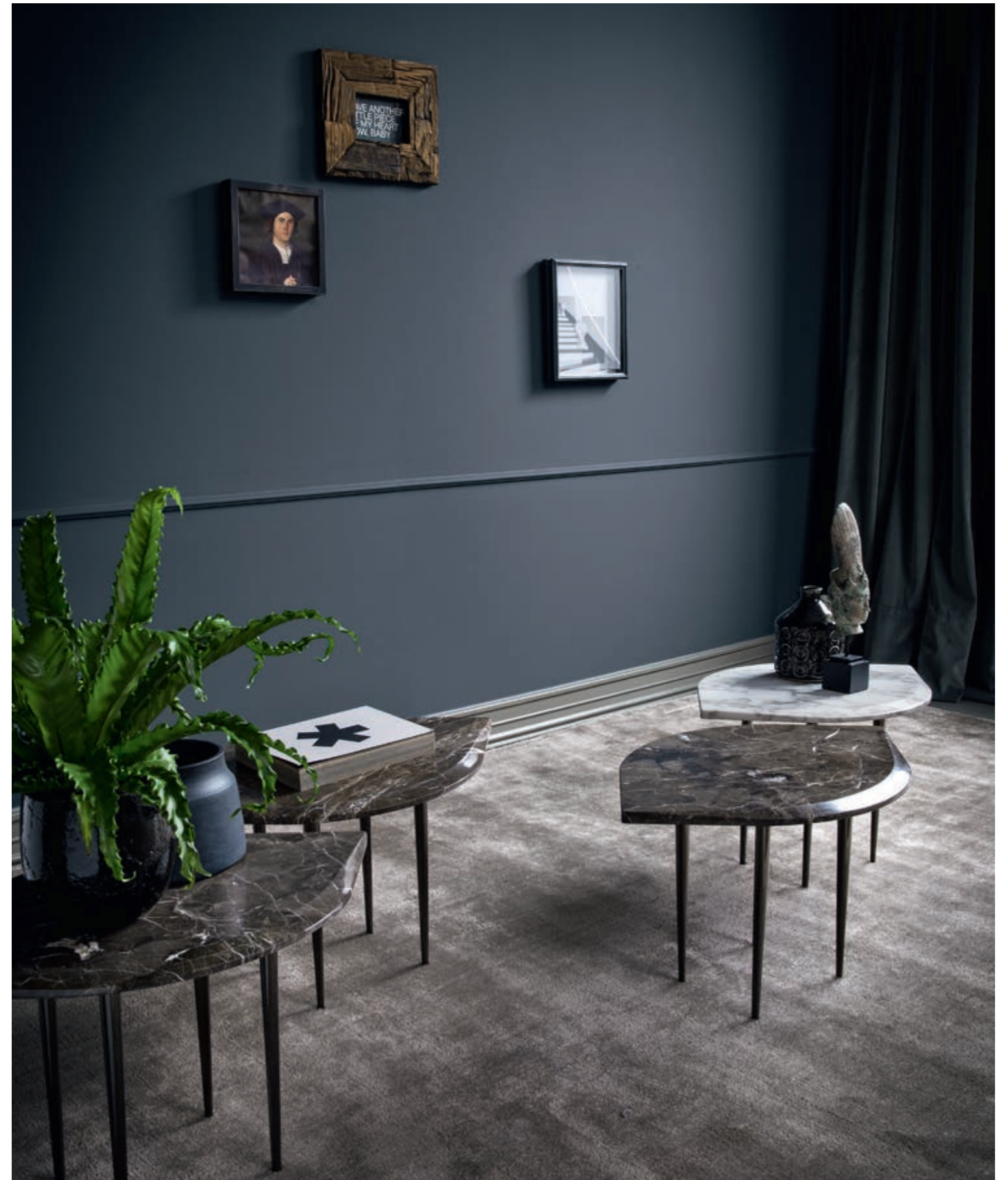

# CINQUANTA

DESIGN  
GIUSEPPE  
MANZONI  
2016



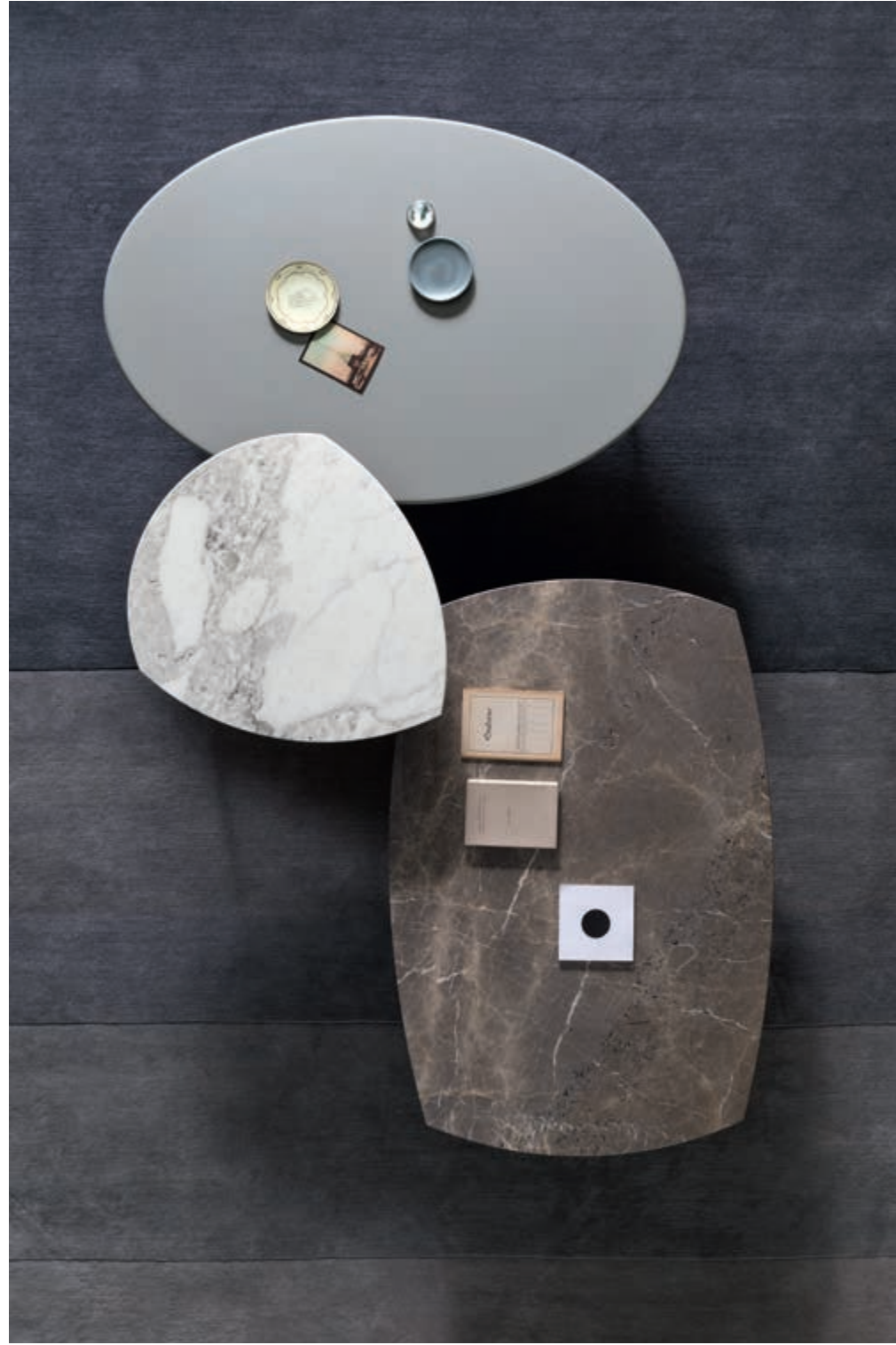

COMPLEMENTI  
— complements

poltrona — *armchair*  
GRACE

tavolini — *low tables*  
CINQUANTA



## BIPEDA

DESIGN  
GIUSEPPE  
MANZONI  
2014



## CLESSIDRA

DESIGN  
GIUSEPPE  
MANZONI  
2014



**PONTE**

DESIGN  
GIUSEPPE  
MANZONI  
2014

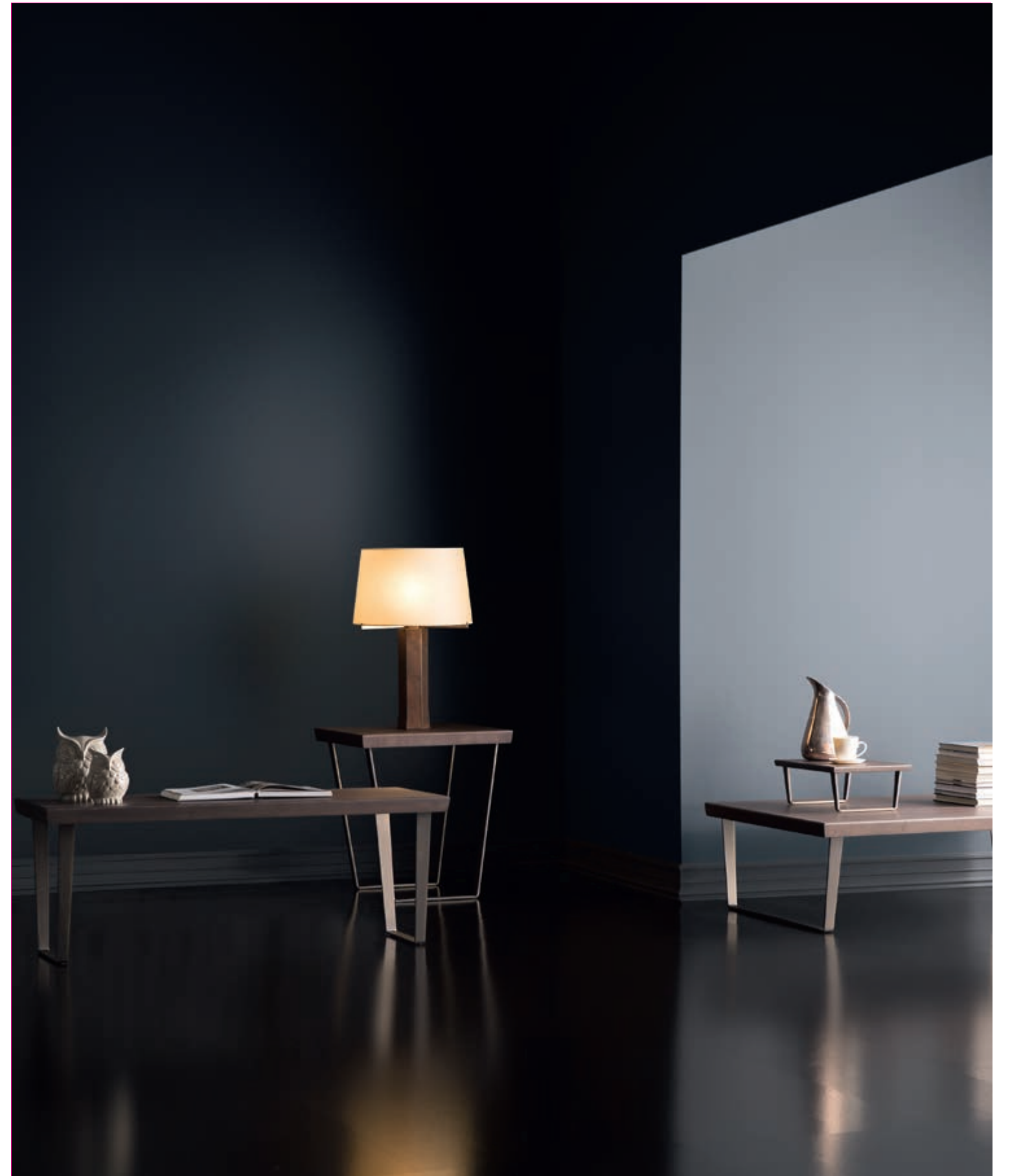

## SIEVE

DESIGN  
NCB ARCHITETTURA  
2012

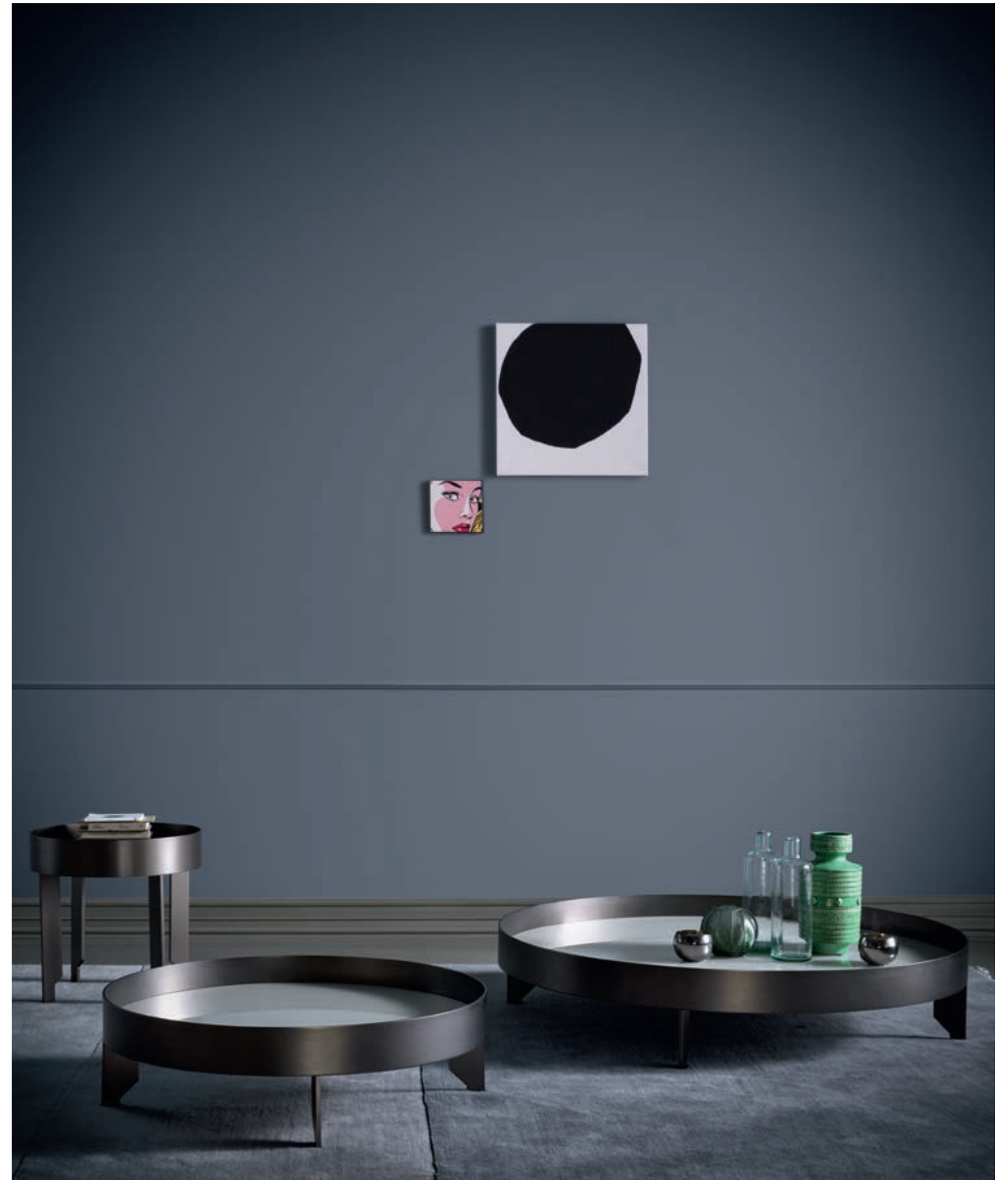



# SUMO

DESIGN  
GIUSEPPE  
MANZONI  
2017



COMPLEMENTI  
— complements

pouf — ottoman  
SUMO



## BUTTON

DESIGN  
STUDIO  
RES  
2019

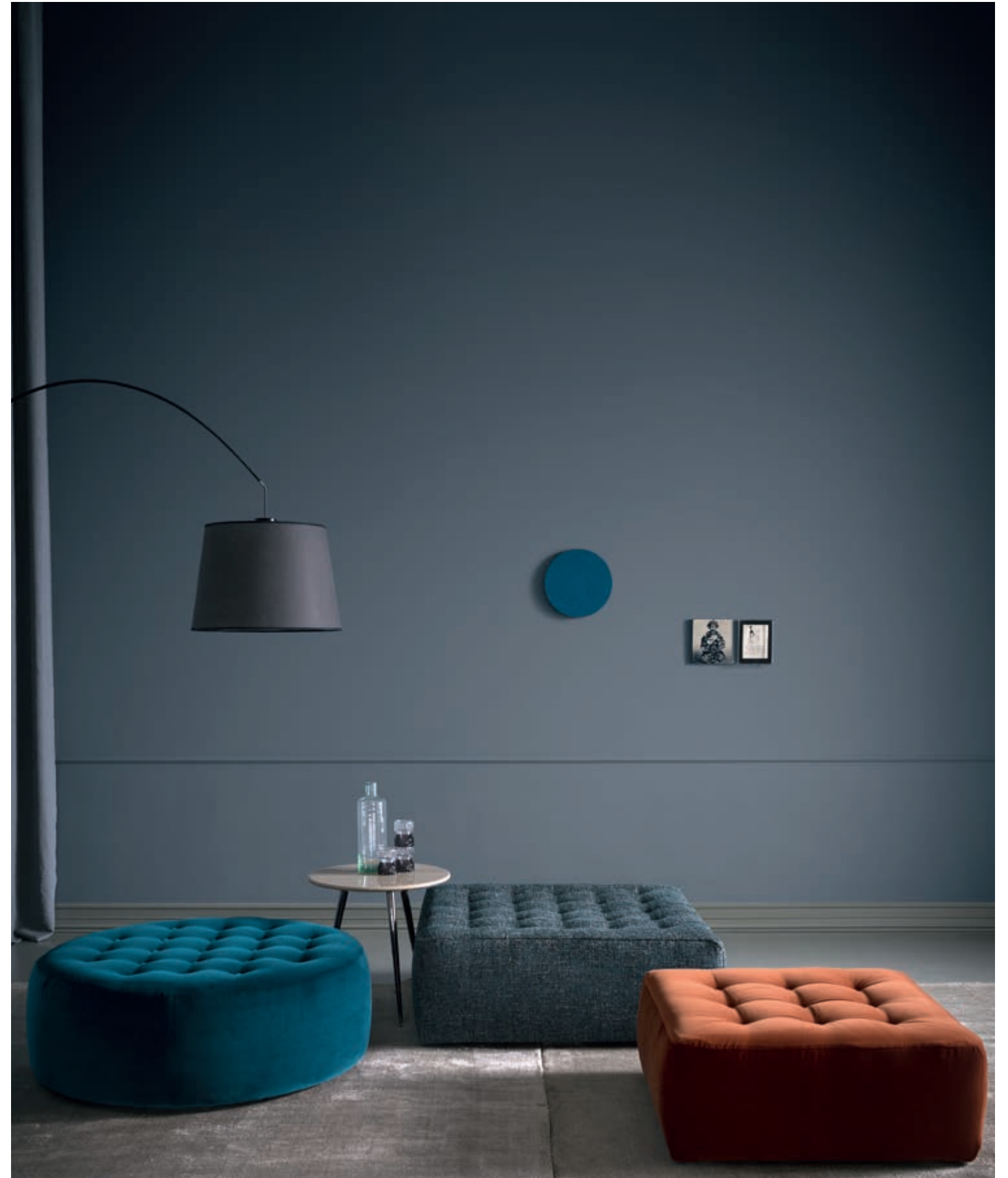

# CUSHIONS

— DESIGN AS CAREFUL TAILORING JOB  
ON DETAILS

Una cucitura insolita e un'imbottitura più ricca. Un colore selezionato tra infinite possibili sfumature. Differenze a volte impercettibili che fanno di quel pezzo qualcosa di unico. Perché Bodema concepisce il design come attento lavoro sartoriale sui dettagli.

An unusual stitching and a richer padding. A color selected among endless possible nuances. Differences, which may be sometimes imperceptible, but which make that piece something unique because Bodema conceives design as careful tailoring work on details.

Eine ungewöhnliche Naht und dickere Polsterung. Eine Farbe, die aus unendlich vielen möglichen Nuancen ausgewählt wird. Unterschiede, die manchmal nicht wahrgenommen werden können, machen das Stück einzigartig. Denn Bodema versteht Design als sorgfältige Detailarbeit.

Une couture inhabituelle et un rembourrage plus riche. Une couleur choisie parmi une infinité de nuances possibles. Des différences parfois imperceptibles font de cette pièce un objet unique. Parce que Bodema conçoit le design comme un travail de personnalisation minutieux.

Необычный шов и более богатая набивка. Цвет выбран среди бесконечных возможных нюансов. Различия иногда незаметны, что делает этот предмет чем-то уникальным. Потому что Бодема воспринимает дизайн как тщательный пошив деталей.

不寻常的接缝方式和更丰富的填充物。Bodema 从细微差别中精挑细选色彩，赋予这件作品独特性，使它更加温馨舒适和更受欢迎。Bodema 将设计视为细节上的精心剪裁。





CUSCINETTO A SAPONETTA

PRODUCT TYPE  
A

IMBOTTITO  
FIBRA DI POLIESTERE

SIZE CM  
40 X 40



CUSCINETTO A SAPONETTA

PRODUCT TYPE  
B

IMBOTTITO  
FIBRA DI POLIESTERE

SIZE CM  
50 X 50



CUSCINETTO A SAPONETTA

PRODUCT TYPE  
C

IMBOTTITO  
FIBRA DI POLIESTERE

SIZE CM  
60 X 60



CUSCINETTO CON PROFILO

PRODUCT TYPE  
D

IMBOTTITO  
PIUMA

SIZE CM  
50 X 50



CUSCINETTO CON ANGOLI CUCITI

PRODUCT TYPE  
E

IMBOTTITO  
PIUMA - TAGLIATO E CUCITO A GIRO

SIZE CM  
45 X 45



CUSCINETTO CON ANGOLI CUCITI

PRODUCT TYPE  
F

IMBOTTITO  
PIUMA - TAGLIATO E CUCITO A GIRO

SIZE CM  
60 X 60



CUSCINETTO A SAPONETTA

PRODUCT TYPE  
N

IMBOTTITO  
PIUMA

SIZE CM  
40 X 60



CUSCINETTO CON BORDO

IMBOTTITO  
FIBRA

SIZE CM  
55 X 55



CUSCINETTO CON DOPPIO VOLANT

IMBOTTITO  
FIBRA

SIZE CM  
45 X 45



CUSCINETTO TONDO CON FASCIA

PRODUCT TYPE  
M

IMBOTTITO  
PIUMA

SIZE CM  
Ø 45



POGGIARENI

PRODUCT TYPE  
L

IMBOTTITO  
FIBRA DI POLIESTERE

SIZE CM  
L50 P12 H24



RULLO BRACCIOLO

IMBOTTITO  
FIBRA DI POLIESTERE

SIZE CM  
L55 Ø 15



CUSCINETTO CON CUCITURA

PRODUCT TYPE  
T

IMBOTTITO  
PIUMA - TAGLIATO E CUCITO A GIRO

SIZE CM  
50 X 50



CUSCINETTO CON RICAMO

PRODUCT TYPE  
R

IMBOTTITO  
PIUMA

SIZE CM  
50 X 50

# — rugs

## LA TECNICA

In Tibet si usa una tecnica di tessitura dei tappeti esclusiva. Davanti all'ordito viene, temporaneamente, posta una bacchetta che definisce l'altezza del pelo. Un filo continuo viene avvolto intorno a due fili dell'ordito e, successivamente, una volta intorno alla bacchetta. Quando è completata un'intera linea di fili essi vengono tagliati per creare i nodi.

## THE PROCESS

In Tibet an exclusive rug weaving technique is used. A wand, which defines the height of the hair, is temporarily placed in front of the warp. A continuous thread is constantly wrapped around two threads of the warp and later one time around the wand. When the entire threads line is completed, they are cutted to be knotted.

## DIE TECHNIK

In Tibet wird eine exklusive Teppichwebtechnik angewendet. Ein Rührstab, das die Höhe des Haars definiert, wird vorübergehend vor die Kette gelegt. Ein durchgehender Faden wird einmal um zwei Fäden der Kette und anschließend um den Stab gewickelt. Wenn eine ganze Reihe von Fäden abgeschlossen ist, werden sie geschnitten, um die Knoten zu erstellen.

## LA TECHNIQUE

Au Tibet, une technique exclusive de tissage de tapis est utilisée. Une baguette, qui définit la hauteur du cheveu, est temporairement placée devant la chaîne. Un fil continu est enroulé autour de deux fils de la chaîne et, ensuite, autour de la baguette une fois. Quand une ligne entière de fils est terminée, ils sont coupés pour créer les nœuds.

## ТЕХНИКА

В Тибете мы используем технику эксклюзивное ковроткачество. Перед варпом приходит временно, подать палочку который определяет высоту волос. Приходит непрерывная нить обернутый вокруг двух нитей основы и, впоследствии, один вокруг палочки. Когда все завершено линия проводов они приходят вырезать, чтобы создать узлы.

## 地毯

在西藏,工匠们会使用独特的地毯编织技术。将决定纱线长度的纱棒放在经纱机前面,一根连续的纬线不断缠绕在经纱机的两根经线上,然后围绕纱棒缠绕下来;当全部经纬线编织完成时,它们被切割然后打结成毯子。

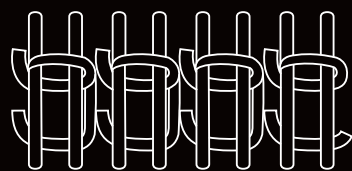
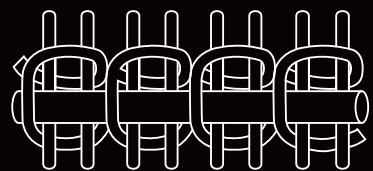

# 08



TAPPETI  
— rugs

poltrona — *armchair*  
NINA

tavolini — *low tables*  
BIPEDA

tappeto — *rug*  
LAND DOVE

**LAND**  
DESIGN  
GIUSEPPE  
MANZONI  
2015

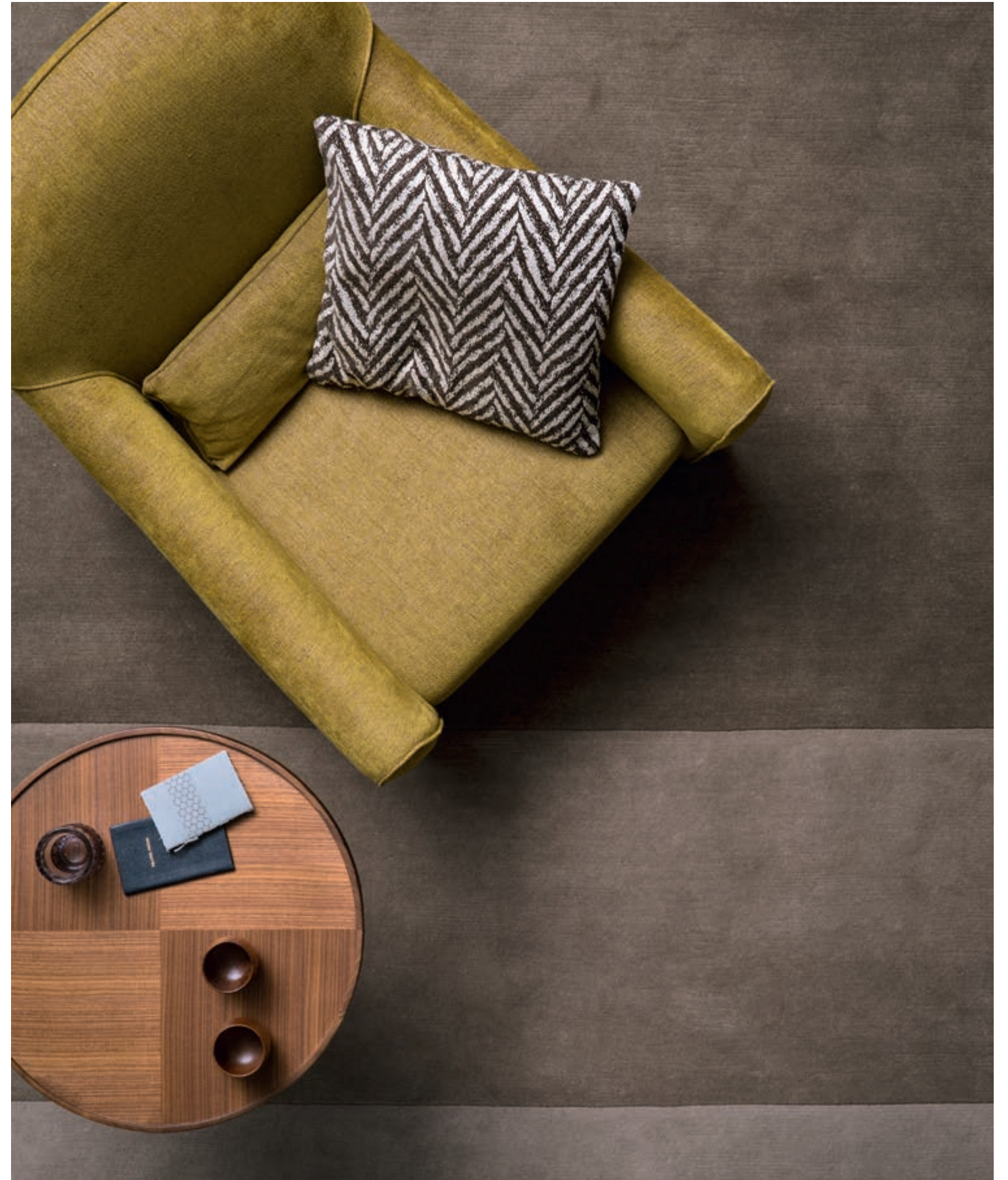

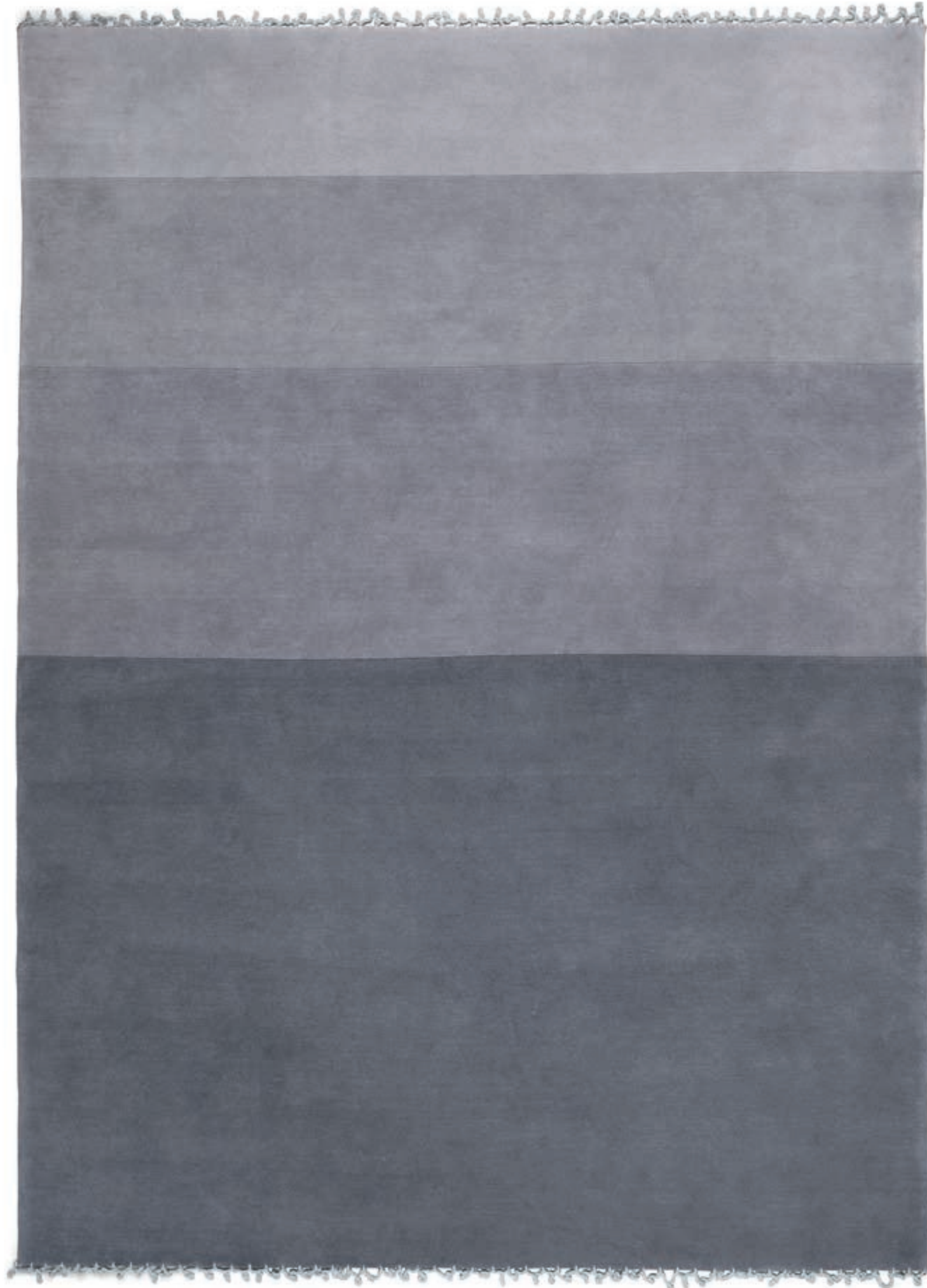

LAND COLOURS



**GREY**  
  
MATERIALI  
**LANA**  
  
ORDITO  
**COTONE**  
  
SIZE CM  
**250 X 350**  
**200 X 300**  
**170 X 240**



**TURTLEDOVE**  
  
MATERIALI  
**LANA**  
  
ORDITO  
**COTONE**  
  
SIZE CM  
**250 X 350**  
**200 X 300**  
**170 X 240**

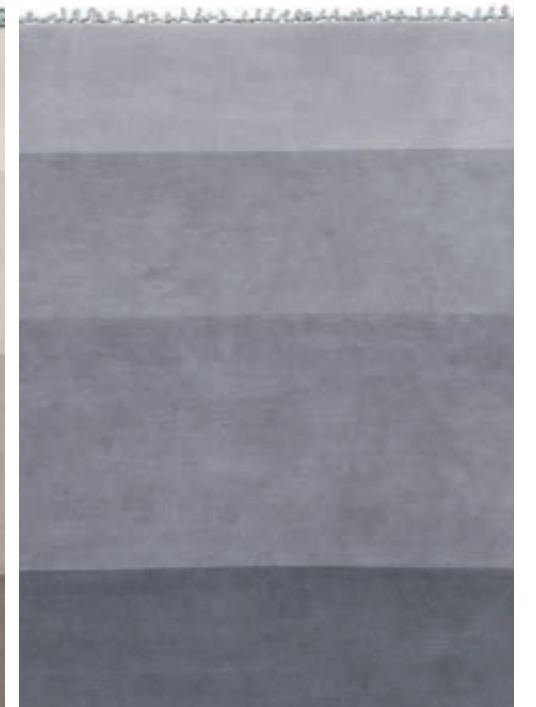

**LAVA**  
  
MATERIALI  
**LANA**  
  
ORDITO  
**COTONE**  
  
SIZE CM  
**250 X 350**  
**200 X 300**  
**170 X 240**

# WATER

DESIGN  
GIUSEPPE  
MANZONI  
2015

TAPPETI  
— rugs

pouf — ottoman  
BUTTON

tappeto — rug  
WATER GREY







WATER / COLOURS



GREY

MATERIALI  
LANA  
VISCOSA

ORDITO  
COTONE

SIZE CM  
250 X 350  
200 X 300  
170 X 240



TURTLEDOVE

MATERIALI  
LANA  
VISCOSA

ORDITO  
COTONE

SIZE CM  
250 X 350  
200 X 300  
170 X 240



LAVA

MATERIALI  
LANA  
VISCOSA

ORDITO  
COTONE

SIZE CM  
250 X 350  
200 X 300  
170 X 240

# beds

09



**SOPHIE**

DESIGN  
GIUSEPPE  
MANZONI  
2019

CONTENITORE





LETTI  
— beds

letto — bed  
SOPHIE



LETTI  
— beds

letto — bed  
SOPHIE  
poltrona — armchair  
INGRID

comodini — nightstands  
PROFILE



**DALLAS**

DESIGN  
GIUSEPPE  
MANZONI  
2019

CONTENITORE



LETTI  
— beds

letto — bed  
DALLAS



250 — 251

bodema

LETTI  
— beds

letto — bed  
DALLAS  
pouf — ottoman  
BUTTON

comodini — nightstands  
PROFILE





**TOKYO**

DESIGN  
GIUSEPPE  
MANZONI  
2019



LETTI  
— beds

letto — bed  
TOKYO



256 — 257

bodema



# AURORE

DESIGN  
GIUSEPPE  
MANZONI  
2019

CONTENITORE

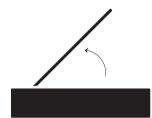



LETTI  
— beds

letto — bed  
AURORE



LETTI  
— beds

letto — bed  
AURORE  
poltrona — armchair  
KIM

comodini — nightstands  
PROFILE



**HARRY**

DESIGN  
STUDIO  
RES  
2019





LETTI  
— beds

letto — bed  
HARRY

comodini — nightstands  
PROFILE





LETTI  
— beds

letto — bed  
HARRY  
poltrona — armchair  
INGRID

comodini — nightstands  
PROFILE



**MEGAN**

DESIGN  
STUDIO  
RES  
2019



LETTI  
— beds

letto — bed  
MEGAN  
poltrona — armchair  
HAVANA SMALL

comodini — nightstands  
PROFILE

pouf — ottoman  
BUTTON





LETTI  
— beds

letto — bed  
MEGAN



LETTI  
— beds

letto — bed  
MEGAN  
poltrona — armchair  
INGRID  
pouf — ottoman  
SUMO, BUTTON

comodini — nightstands  
PROFILE



## NEW ALICANTE

DESIGN  
STUDIO  
RES  
2019

CONTENITORE

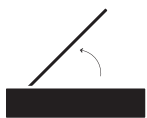

LETTI  
— beds

letto — bed  
NEW ALICANTE  
poltrona — armchair  
NINA

comodini — nightstands  
PROFILE

tappeto — rug  
WATER LAVA



## VIOLET

DESIGN  
GIUSEPPE  
MANZONI  
2019

CONTENITORE

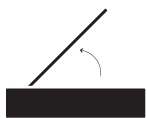



LETTI  
— beds

letto — bed  
VIOLET



286 — 287

bodema

LETTI  
— beds

letto — bed  
VIOLET  
poltrona — armchair  
INGRID

comodini — nightstands  
PROFILE



# TIFFANY

DESIGN  
ADRIANO  
CASTIGLIONI  
2009

CONTENITORE

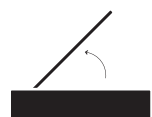



**LULU'**  
DESIGN  
STUDIO  
RES  
2009

CONTENITORE



LETTI  
— beds

letto — bed  
LULU' —  
poltrona — armchair  
KIM

comodino — nightstand  
PROFILE  
console — console  
PROFILE



---

# tech nical info

# 10



# STORAGE BASE

— PRODUCED WITH CARE BY LEADING COMPANIES IN THE FIELD

Tutti i meccanismi e le reti utilizzate sono rigorosamente Made in Italy, prodotti con cura da aziende leader nel loro settore ed in possesso delle più recenti evoluzioni tecnologiche e dei materiali.

All the mechanisms and springs used are strictly Made in Italy, produced with care by leading companies in the field and in possession of the most recent technological developments and materials.

Alle verwendeten Systemen und Mechanik werden streng in Italien hergestellt. Sie werden von führenden Unternehmen ihres Sektors sorgfältig hergestellt und verfügen über die neuesten technologischen Entwicklungen und Materialien.

Tous les systèmes et les mécanismes utilisés sont rigoureusement Made in Italy, produits avec soin par des entreprises leaders dans leur secteur et en possession des technologies et matériaux les plus récents.

Все используемые механизмы и сети строго произведены в Италии, произведены с осторожностью ведущими компаниями своего сектора и с учетом самых последних технологических разработок и материалов.

使用的材料和弹簧都是100%意大利严格制造，由该领域的领先供应商精心生产，拥有最新的技术和材料。





# FINISHES

— METAL, MARBLE, GLASS, WOOD  
AND LEATHER

Il metallo, il marmo, il vetro, le essenze del legno e le declinazioni del pellame; la capacità di selezionare e cogliere i materiali più attuali per le finiture dei prodotti è una cultura ed una capacità che si migliora e si raffina nel tempo e col tempo.

Metal, marble, glass, wood essences and a wide leather range; the ability to select and catch the most current materials for product finishings is a culture and a capacity improved and refined over the years.

Metall, Marmor, Glas, die Essenzen des Holzes und die Typologien des Leders; die Fähigkeit, die aktuellsten Materialien für die Endbearbeitung der Produkte auszuwählen und zu erfassen, ist eine Kultur und eine Kapazität, die mit der Zeit und im Laufe der Zeit verbessert und verfeinert wird.

Le métal, le marbre, le verre, les essences de bois et les typologies du cuir; la capacité de sélectionner et de comprendre les matériaux les plus courants pour la finition des produits est une culture et une capacité qui sont améliorées et affinées au fil du temps.

Металл, мрамор, стекло, эссенции дерева и склонения кожи; способность выбирать и воспринимать самые современные материалы для отделки продуктов - это культура и способность, которая совершенствуется и совершенствуется с течением времени.

金属, 大理石, 玻璃, 木质精华和广泛的皮革系列; 精选最新材料进行产品加工是Bodema多年来不断发展和完善的重要因素。

## MARMI — marbles



BROWN EMPERADOR  
lucido / opaco  
glossy / matt

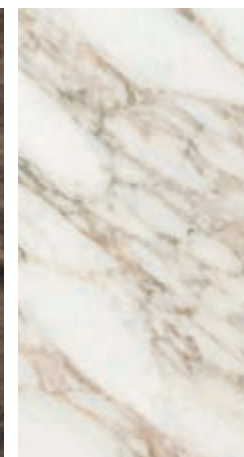

CALACATTA ORO  
lucido / opaco  
glossy / matt

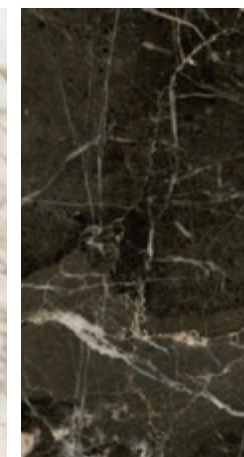

MARRON DAMASCO  
lucido / opaco  
glossy / matt

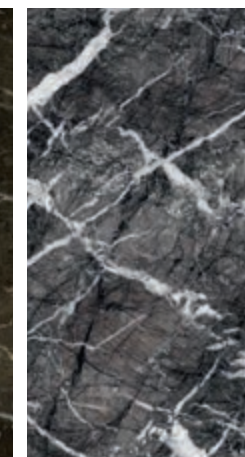

STARDUST  
lucido / opaco  
glossy / matt

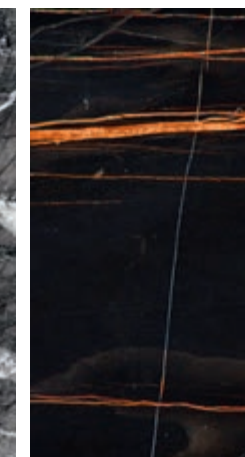

SAHARA NOIR  
lucido / opaco  
glossy / matt

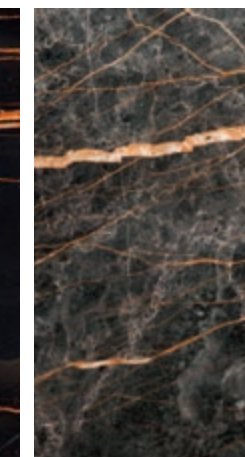

SAINT LAURENT  
lucido / opaco  
glossy / matt

## ESSENZE — wood

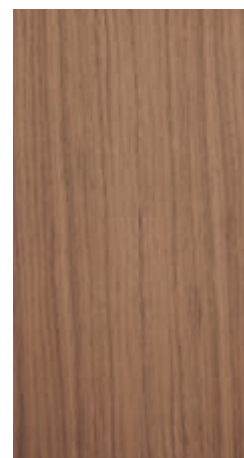

NOCE  
WALNUT



NOCE CANALETTO  
CANALETTO WALNUT



ROVERE SBIANGATO  
WHITE-WASHED OAK

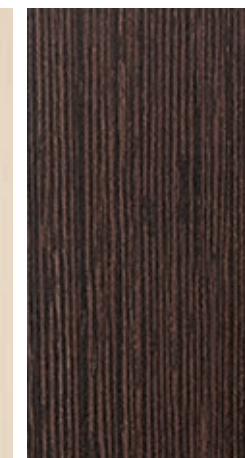

WENGÈ  
WENGÈ



ROVERE TERMOCOTTO  
SMOKED OAK BROWN

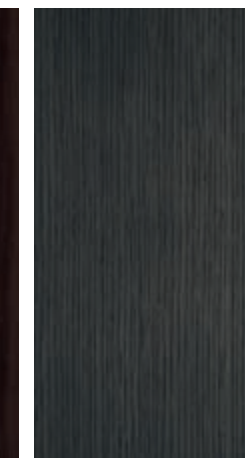

FRASSINO TINTO ANILINA  
ASHWOOD IN ANILINE FINISH

## VETRO — glass



VETRO RETROLACCATO  
LACQUERED GLASS

## METALLI

— *metals*



BRONZO SPAZZOLATO  
SANDED BRONZE



NICHEL NERO  
BLACK NICKEL



CROMO LUCIDO  
GLOSSY CHROME



CROMO SATINATO  
SATIN CHROME



OTTONE  
BRASS



NERO OPACO  
MATT BLACK

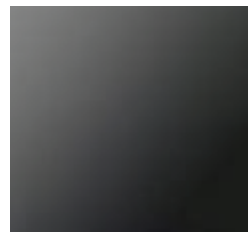

ANTRACITE MANGANESE  
OPACO  
MATT MANGANESE GREY

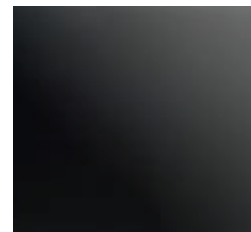

ALLUMINIO ANODIZZATO  
ANTRACITE  
ANTHRACITE ANODIZED ALU



ALLUMINIO SATINATO  
SATIN ALU



ALLUMINIO BIANCO LUCIDO  
GLOSSY WHITE ALU

## PELLE

— *leather*

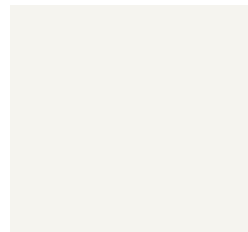

BIANCO  
WHITE

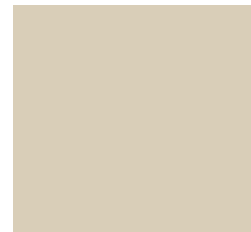

CORDA  
ÉCRU



SAVANA  
SAVANA



NATURALE  
NATURAL



TABACCO  
TOBACCO



BULGARO  
BULGARO RED

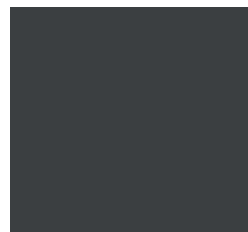

GRIGIO  
GREY

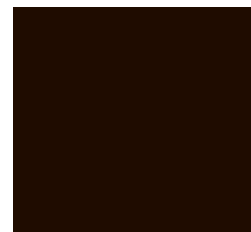

TESTA DI MORO  
DARK BROWN

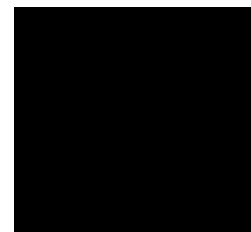

NERO  
BLACK

## INDEX

### — TECHNICAL INFORMATION

#### DIVANI

— *sofas*

306 ANYWAY  
307 BARCLAY  
308 BLAKE  
312 BURANO  
313 DALLAS  
315 DOUGLAS  
316 ÉTIME  
317 KYOTO  
318 LONDON  
320 MANHATTAN  
321 MR FLOYD  
322 MUCH MORE  
323 MURANO  
323 QUENTIN  
324 SHANGHAI  
326 TOKYO

#### POLTRONE

— *armchairs*

327 CAROL  
327 DOVEVUOI  
328 GRACE  
328 HAVANA  
329 HAVANA LOUNGE  
329 HAVANA SMALL  
330 INGRID  
330 KIM  
331 LÙ  
331 MARILYN  
332 MARYANNE LOUNGE  
332 NICOLE  
333 NINA  
333 OLEANDRA

#### CONTENITORI

— *storage*

334 PROFILE

#### TAVOLI E SEDIE

— *tables and chairs*

335 BLAKE LOW TABLE  
335 CI LOW TABLE  
336 MONICA  
336 PEGGY

#### TAVOLINI/POUF

— *low tables/ottoman*

337 BIPEDE  
337 BLAKE  
338 BLUNT  
338 BUTTON  
339 CHIO  
339 CI LOW TABLE  
339 CINQUANTA  
340 CLESSIDRA  
340 PONTE  
341 SIEVE  
341 SUMO

#### LETTI

— *beds*

342 AURORE  
343 DALLAS  
344 HARRY  
345 LULÙ  
346 MEGAN  
347 NEW ALICANTE  
348 SOPHIE  
349 TIFFANY  
349 TOKYO  
350 VIOLET

#### CONTENITORI

— *storage*

351 PROFILE

Programma di sedute ed elementi componibili dal design innovativo e dalle linee morbide. Struttura in legno, imbottita in poliuretano espanso a quote differenziate + rivestimento accoppiato con resinato 100gr. Piano seduta in poliuretano espanso D35. Cuscini di schienale in poliuretano espanso D21 + falda in termolegato. Basamento in alluminio, disponibile nelle finiture satinato, bianco lucido ed anodizzato color antracite.

Upholstery program of seating and modular elements of innovative and soft-shaped design. Wooden structure, upholstery in polyurethane of different weight space with cotton cover. Seat cushions upholstered with D21 polyurethane and thermofastened layer. Alu base available in sanded finish, glossy white lacquer and anthracite.

System aus kombinierbaren Sofaelementen in einem innovativen Design mit weicher Linienführung. Holzrahmen verkleidet mit Polyurethanschaum in verschiedenen Dichten verbunden mit Polyesterfaser und Harzschicht 100gr. Sitz aus Polyurethanschaum D35. Rückenkissen aus Polyurethanschaum D21 mit einer thermolegierten Schaumstoffschicht. Aluminiumsockel, der satiniert, weiß glänzend oder anthrazit eloxiert erhältlich ist.

Programme d'assises et éléments composables au design novateur aux lignes douces. Structure en bois revêtue en polyuréthane expansé avec différente masse volumique + revêtement doublé avec feuille résine 100gr. Assise en polyuréthane expansé D35. Coussin du dossier en polyuréthane expansé D21 + feuille thermo lié. Base en aluminium disponible dans les versions: satiné, blanc brillant ou anthracite.

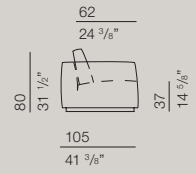

larghezza bracciolo 22 cm  
arm width 8 7/8"

**AW0000**  
armchair 110

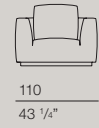

**AW0033**  
armchair big 130

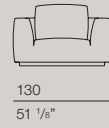

**AW0001**  
sofa 190

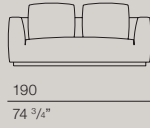

**AW0002**  
sofa 210

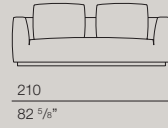

**AW0003**  
sofa 230

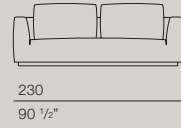

**AW0004**  
sofa 250

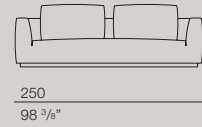

**AW0005**  
end element 95



**AW0006**  
end element 105



**AW0007**  
end element 125



**AW0008**  
end element 145

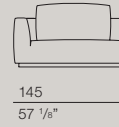

**AW0009**  
end element 165

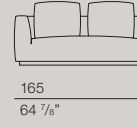

**AW0010**  
end element 185

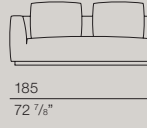

**AW0011**  
end element 205

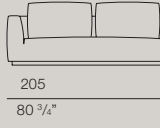

**AW0012**  
end element 225



**AW0017**  
central element 140

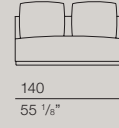

**AW0018**  
central element 160

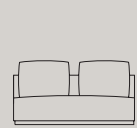

**AW0019**  
central element 180

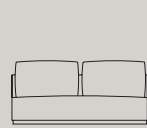

**AW0020**  
central element 200

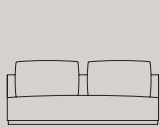

**AW0021**  
chaise longue 100 x 160

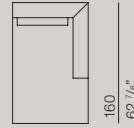

**AW0022**  
chaise longue 120 x 160

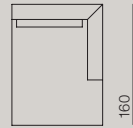

**AW0013**  
squared element 100 x 100



**AW0023**  
ottoman 100 x 100

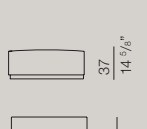

**AW0024**  
ottoman 100 x 160



**AW0025**  
central element with ottoman 140 x 105

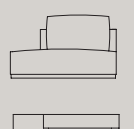

**AW0026**  
central element with ottoman 160 x 105

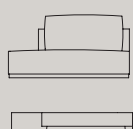

**AW0027**  
central element 140 D125

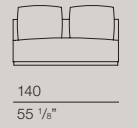

**AW0028**  
central element 160 D125

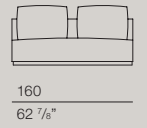

**AW0029**  
central element 180 D125

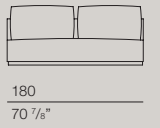

**AW0030**  
central element 200 D125

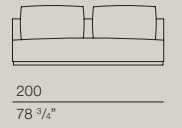

**AW0031**  
central element with ottoman 140 X 125

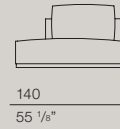

**AW0032**  
central element with ottoman 160 x 125

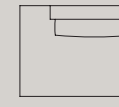
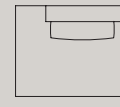
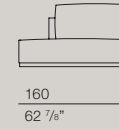

BARCLAY DESIGN GIUSEPPE MANZONI

Struttura in legno rivestita in poliuretano espanso indeformabile e vellutino accoppiato. Molleggio a cinghia elastica intrecciata. Imbottitura seduta in piuma d'oca trapuntata con inserto in poliuretano espanso D35 e D25. Schienali in piuma d'oca.

Wooden structure and non-deformable polyurethane upholstery with light double velvet cover. Springiness made of woven elastic belts. Seat cushions in quilted goose feather and D35 +D25 polyurethane insert. Back cushions filled with goose feather.

Holzrahmen verkleidet mit formbeständigem Polyurethanschaum und Polyesterfaser. Federung bestehend aus elastischen verwebten Gurten. Gestepte Sitzpolsterung aus Gänsedaunen mit Kern aus Polyurethanschaum D35 + D25. Rückenkissen aus Gänsedaunen.

Structure en bois revêtue en polyuréthane expansé indéformable et toile de coton doublé. Suspension ceintures entrelacées. Assise en plume d'oie matelassé avec insert en polyuréthane expansé D35 et D25. Coussins dossier en plume d'oie.

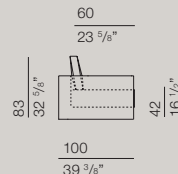

larghezza bracciolo 19 cm  
arm width 7 1/2"

**BARC001**  
armchair 110

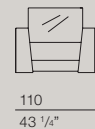

**BARC002**  
sofa 178

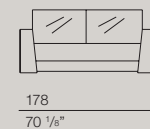

**BARC003**  
sofa 198

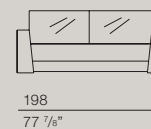

**BARC004**  
sofa 218

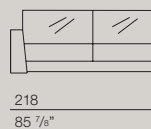

**BARC005**  
sofa 238

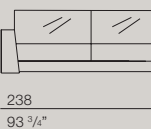

**BARC006**  
sofa 258

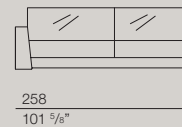

**BARC007**  
sofa 278

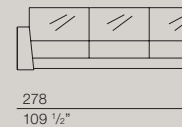

**BARC027**  
end element 90



**BARC028**  
end element 100

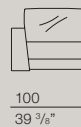

**BARC029**  
end element 110

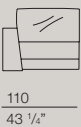

**BARC030**  
end element 120



**BARC031**  
end element 130



**BARC012**  
end element 160

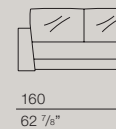

**BARC013**  
end element 180

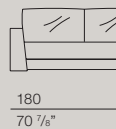

**BARC014**  
end element 200

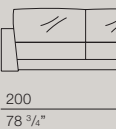

**BARC015**  
end element 220

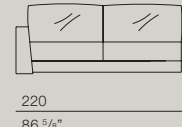

**BARC016**  
end element 240

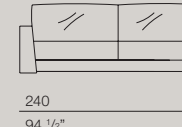

**BARC017**  
end element 260

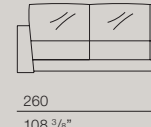

**BARC008**  
central element 140

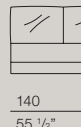

**BARC009**  
central element 160

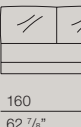

**BARC010**  
central element 180

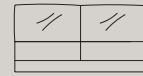

180  
70 7/8"

**BARC018**  
chaise longue 100 x 175

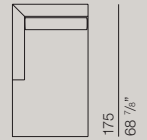

100  
39 3/8"

**BARC019**  
chaise longue 120 x 175

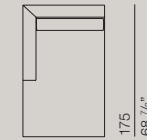

120  
47 1/4"

**BARC022**  
ottoman 100 x 100

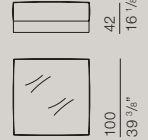

100  
39 3/8"

**BARC020**  
central element  
with ottoman 240 X 100

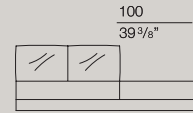

240  
94 1/2"

**BARC021**  
central element  
with ottoman 260 X 100

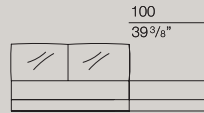

260  
102 3/8"

**BARC026**  
end element  
with ottoman 210 X 100

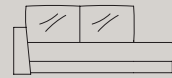

210  
82 5/8"

**BARC023**  
end element  
with ottoman 230 X 100

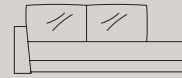

230  
90 1/2"

**BARC024**  
end element  
with ottoman 250 X 100

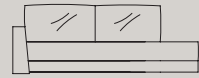

250  
98 3/8"

**BLAKE DESIGN ADRIANO CASTIGLIONI**

Programma di sedute ed elementi componibili. Braccioli imbottiti disponibili nelle larghezze di 10, 20 e 30 cm. Struttura in legno, imbottita in poliuretano espanso a quote differenziate + rivestimento accoppiato con resinato 100 gr. Molleggio a cinghia elastica intrecciata. Imbottitura seduta in Poliuretano HT35 + Poliuretano D21 rivestiti in vellutino accoppiato bianco. Cuscini di schienale in piuma con inserto di in poliuretano espanso D21SOFT. Piedini in metallo disponibili nella finitura Nickel nero, bronzo spazzolato o verniciato opaco color peltro. Divano completamente smontabile. Completano la collezione due mobiletti contenitore in legno, disponibili nella finitura Rovere Termocotto. La collezione Blake comprende anche una serie di tavolini, console e tavoli da pranzo, con basamento in metallo disponibile nelle finiture Nickel nero, bronzo spazzolato o verniciato opaco color peltro; il piano è disponibile in MDF laccato lucido o opaco in tutti i colori RAL, oppure in marmo Brown Emperador, Calacatta Oro, Sahara Noir, Saint Laurent, Marron Damasco e Stardust lucido o opaco.

Seat and modular elements program. Arms available in cm 10 - 20 and 30. Wooden frame, polyurethane upholstery of different space weight with 100 gr double cover. Woven elastic belts. Seat upholstery in HT35 and D21 polyurethane covered with light double velvet. Back cushions in goose feather with D21 SOFT polyurethane insert. Metal feet in black nickel, sanded bronze or matt pewter finish. Totally Knock-down sofa for an easier delivery and installation. 2 cabinets belong to this collection, available in smoked oak brown, besides coffee-tables, console-table and dining set with matching metal base in the same finish of the sofa. Top is available in any RAL colour tone, glossy or matt pewter finish. Option is a glossy or mat marble top in Brown Emperador, Calacatta Oro, Sahara Noir, Saint Laurent, Marron Damasco and Stardust.

System aus kombinierbaren Sofaelementen. Gepolsterte Armlehnen in den Breiten cm 10, 20 und 30 verfügbar. Holzrahmen verkleidet mit Polyurethanschaum D40 in angepassten Dichten und Baumwolleinlett verbunden mit Harz 200 gr. Federung durch elastischen verwebten Gurten. Sitzpolsterung aus HT35 Polyurethanschaum + D21 Polyurethanschaum, mit weißem Baumwollnessel bezogen. Rückenkissen aus Gänsedaunen mit Kern aus Polyurethanschaum D21 Soft. Metallfüße schwarz Nickel, gebürstete Bronze oder Hartzinn mattlackiert. Völlig zerlegbares Schlafsofa. Ergänzt wird die Kollektion durch zwei kleine Magazinschränke, auf dunkelbraune Eiche gebeizt. Blake umfasst auch Couchtischen, Konsolen und Eßtische, mit Metallfüße schwarz Nickel, gebürstete Bronze oder Hartzinn mattlackiert. Tischplatte verfügbar entweder aus MDF glänzend oder matt lackiert auf alle RAL Farbe, oder aus Marmor Brown Emperador, Calacatta Oro, Sahara Noir, Saint Laurent, Marron Damasco und Stardust - glänzend oder matt.

Programme d'assises et éléments composables. Accoudoirs rembourrés, largeurs disponibles cm 10, 20 et 30 Structure en bois revêtu en polyuréthane expansé avec différente masse volumique + revêtement doublé avec feuille résine 100gr. Suspension ceintures entrelacées. Coussins d'Assise en polyuréthane HT35 + Polyurethane D21 revêtu avec toile de coton doublé blanc. Coussins dossier en plume avec insert en polyuréthane expansé D21 Soft. Pied en métal finissage Nickel noir, bronze brossé ou teinte étain mat. Complètement démontable. La collection est complétée par deux petits placards en bois en chêne noirciet comprends aussi des petites tables, des consoles et des tables à manger, avec pieds en métal disponible en Nickel noir, bronze brossé ou teinte étain mat; top disponible en MDF lacqué brillant ou mat dans toutes couleurs RAL, ou en marbre Brown Emperador, Calacatta Oro, Sahara Noir, Saint Laurent, Marron Damasco et Stardust - brillant ou mat.

**BLA000**  
sofa 185 arms 10



185  
72 7/8"

**BLA001**  
sofa 205 arms 10



205  
80 3/4"

**BLA002**  
sofa 205 arms 20



205  
80 3/4"

**BLA003**  
sofa 205 arm 10  
+ low storage unit



205  
80 3/4"

**BLA004**  
sofa 205 arm 20  
+ low storage unit



205  
80 3/4"

**BLA005**  
sofa 225 arms 10



225  
88 5/8"

**BLA006**  
sofa 225 arms 20

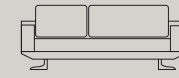

225  
88 5/8"

**BLA007**  
sofa 225 arm 10  
+ low storage unit

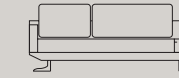

225  
88 5/8"

**BLA008**  
sofa 225 arm 20  
+ low storage unit



225  
88 5/8"

**BLA009**  
sofa 265 arms 10

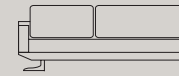

265  
104 3/8"

**BLA010**  
sofa 265 arms 20

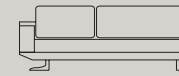

265  
104 3/8"

**BLA011**  
sofa 265 arms 10+30



265  
104 3/8"

**BLA012**  
sofa 265 arm 20  
+ low storage unit



265  
104 3/8"

**BLA013**  
sofa 285 arms 10

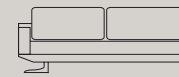

285  
112 1/4"

**BLA014**  
sofa 285 arms 20



285  
112 1/4"

**BLA015**  
sofa 285 arms 10+30

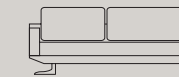

285  
112 1/4"

**BLA016**  
sofa 285 arms 30



285  
112 1/4"

**BLA017**  
sofa 285 arms 20  
low storage unit



285  
112 1/4"

**BLA018**  
end element 145 arm 10



145  
57 1/8"

**BLA019**  
end element 145 arm 20



145  
57 1/8"

**BLA020**  
end element 145 arm 30



145  
57 1/8"

**BLA021**  
end element 145  
with low storage unit

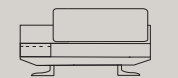

145  
57 1/8"

**BLA022**  
end element 165 arm 10



165  
64 7/8"

**BLA023**  
end element 165 arm 20



165  
64 7/8"

**BLA024**  
end element 165 arm 30

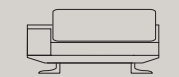

165  
64 7/8"

**BLA025**  
end element 165  
low storage unit

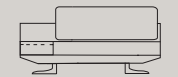

165  
64 7/8"

**BLA027**  
end element 185 arm 10



185  
72 7/8"

**BLA028**  
end element 185 arm 20



185  
72 7/8"

**BLA029**  
end element 185 arm 30

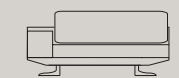

185  
72 7/8"

**BLA030**  
end element 185  
low storage unit



185  
72 7/8"

**BLA031**  
end element 205 arm 10



205  
80 3/4"

**BLA032**  
end element 205 arm 20



205  
80 3/4"

**BLA033**  
end element 205 arm 30

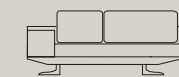

205  
80 3/4"

**BLA034**  
end element 205  
low storage unit

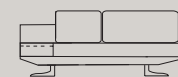

205  
80 3/4"

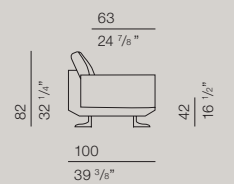

larghezza bracciolo 10,20 o 30 cm  
armrest width 3 7/8", 7 1/8" or 11 3/4"

**BLA035**  
end element 225 arm 10

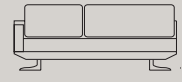

225  
88 3/8"

**BLA036**  
end element 225 arm 20

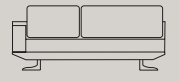

225  
88 3/8"

**BLA041**  
end element 225 arm 30



225  
88 3/8"

**BLA038**  
end element 225  
low storage unit

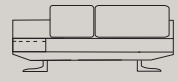

225  
88 3/8"

**BLA039**  
end element 265 arm 10



265  
104 3/8"

**BLA040**  
end element 265 arm 20

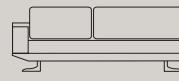

265  
104 3/8"

**BLA043**  
end element 265 arm 30

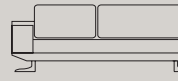

265  
104 3/8"

**BLA037**  
end element 265  
low storage unit

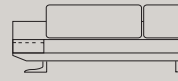

265  
104 3/8"

**BLA044**  
central element 165 with ottoman

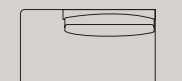
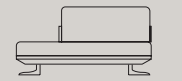

165  
64 7/8"

**BLA046**  
central element 185 with ottoman

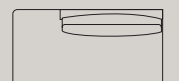
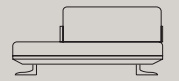

185  
72 7/8"

**BLA048**  
central element 205 with ottoman

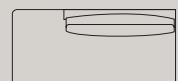
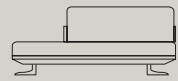

205  
80 3/4"

**BLA045**  
chaise longue 175 x 95 arm 10



175  
68 7/8"

95  
37 3/8"

**BLA047**  
chaise longue 175 x 105 arm 20



175  
68 7/8"

105  
41 3/8"

**BLA077**  
chaise longue 175 x 115 arm 30



175  
68 7/8"

115  
45 1/4"

**BLA042**  
quilted chaise longue 125 x 145  
arm 30



145  
57 1/8"

125  
49 1/4"

**BLA050**  
squared element 227 arm 10



227  
89 3/8"

**BLA056**  
squared element 227 arm 20

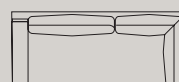

227  
89 3/8"

**BLA052**  
squared element 227 arm 30

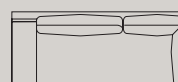

227  
89 3/8"

**BLA053**  
squared element 227  
low storage unit

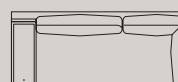

227  
89 3/8"

**BLA058**  
squared element 267 arm 10

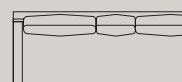

267  
105 1/8"

**BLA055**  
squared element 267 arm 20



267  
105 1/8"

**BLA049**  
squared element 267 arm 30



267  
105 1/8"

**BLA051**  
squared element 267  
low storage unit



267  
105 1/8"

**BLA057**  
squared element 165 with ottoman



165  
64 7/8"

**BLA059**  
squared element 175 with ottoman

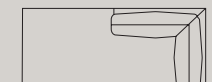

175  
68 7/8"

**BLA054**  
squared element 215 with ottoman

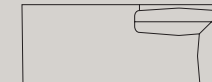

215  
84 3/8"

**BLA060**  
squared element 157 without arm



157  
61 3/4"

**BLA061**  
squared element 167 without arm



167  
65 3/4"

**BLA064**  
squared element 207 without arm

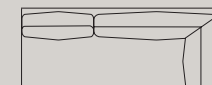

207  
81 1/2"

**BLA066**  
squared element 227 without arm

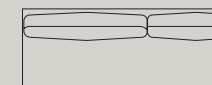

227  
89 3/8"

**BLA071**  
squared element 267 without arm

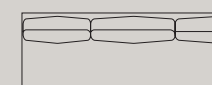

267  
105 1/8"

**BLA062**  
central element 145

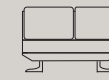

145  
57 1/8"

**BLA063**  
central element 165



165  
64 7/8"

**BLA065**  
central element 205

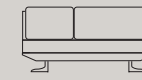

205  
80 3/4"

**BLA070**  
central element 225

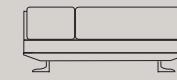

225  
88 3/8"

**BLA068**  
ottoman 100 x 100

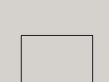

100  
39 3/8"

100  
39 3/8"

**BLA074**  
ottoman 100 x 125



125  
49 1/4"

100  
39 3/8"

**BLA075**  
ottoman 125 x 125

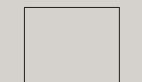

125  
49 1/4"

125  
49 1/4"

**BLA077**  
quilted ottoman 125 x 125

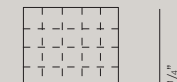

125  
49 1/4"

125  
49 1/4"

**BLA072**  
low storage unit Oak brown finish

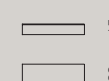

84  
33 1/8"

15  
5 7/8"

29  
11 3/8"

**BLA073**  
high storage unit Oak brown finish

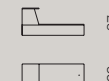

84  
33 1/8"

37  
14 3/8"

29  
11 3/8"

**BURANO** DESIGN GIUSEPPE MANZONI

Serie di poltrone e divani lineari. Struttura in legno, rivestita in poliuretano espanso D40 e vellutino 200 gr accoppiato resinato. Molleggio a cinghia elastica intrecciata. Imbottitura seduta in piuma d'oca etichetta Oro, con inserto Poliuretano D35 e D25 Soft. Imbottitura schienale in piuma d'oca. Piede in legno, disponibile nelle tinte Noce o Wengé.

Upholstery program of seating. Wooden structure and D40 polyurethane expanded D40 with 200GR polyester layer. Springiness made of woven elastic belts. Seat cushions filled in goose feather with D35 and D35SOFT polyurethane insert. Back cushion filled with goose feather. Wooden feet in walnut or wenge stain.

Serie von linearen Sofas und Sessel. Holzrahmen verkleidet mit Polyurethanschaum D40 und Baumwollleint 200 gr. Federung durch elastischen verwebten Gurten. Sitzfüllung aus "Gold Label" Gänsedaunen mit Kern aus Ergolattex D35 + D25. Rückenfüllung aus Gänsedaunen. Holzfuß entweder Nussbaum oder Wengé gebeizt.

Collection de Fauteuils et Canapés Linéaires. Structure en bois revêtu en polyuréthane expansé D40 et toile de coton 200gr doublé. Suspensions avec ceintures entrelacées. Coussins d'Assise en plume d'oie étiquette d'or avec insert en Polyuréthane D35. Coussins Dossier en plume d'oie. Pied en bois, disponibles dans les teintures Noyer ou Wengé.

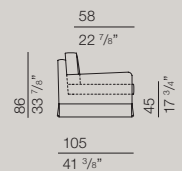

larghezza bracciolo 18 cm  
arm width 7 1/8"

**BUR000**  
armchair 100



100  
39 3/8"

**BUR001**  
sofa 180



180  
70 7/8"

**BUR002**  
sofa 200



200  
78 3/4"

**BUR003**  
sofa 220



220  
86 5/8"

**BUR004**  
sofa 240



240  
94 1/2"

**BUR005**  
sofa 280



280  
110 1/4"

**DALLAS** DESIGN GIUSEPPE MANZONI

Struttura in legno rivestita in poliuretano espanso indeformabile D40 e vellutino accoppiato. Molleggio a cinghia elastica intrecciata. Imbottitura seduta in piuma d'oca trapuntata con inserto in poliuretano espanso D35. Schienali in piuma d'oca trapuntata con inserto in poliuretano espanso D18. Basamento in legno tinto wengé.

Wooden frame upholstered with non-deformable D40 polyurethane foam with light double velvet cover. Springiness made of woven elastic belts. Seat padding in goose feather, quilted with kg.35/ m³ polyurethane foam. Back cushions in goose feather, quilted with kg.18/ m³ polyurethane foam. Wooden base in wengé stain.

Holzrahmen verkleidet mit formbeständigem Polyurethanschaum D40 und Polyesterfaser. Federung durch elastischen verwebten Gurten. Gestepte Sitzpolsterung aus Gänsedaunen mit Kern aus Polyurethanschaum D35. Gestepte Rückenpolsterung aus Gänsedaunen mit Kern aus Polyurethanschaum D18. Holzfuß wenige gebeizt.

Structure en bois revêtu en polyuréthane expansé indéformable D40 et toile de coton doublé. Suspension ceintures entrelacées. Coussins d'Assise en plume d'oie matelassé avec insert en polyuréthane expansé D35. Dossier en plume d'oie matelassé avec insert en polyuréthane expansé D18. Pieds en bois teinté wengé.

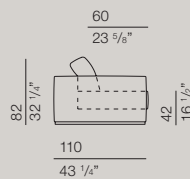

Larghezza bracciolo 25 cm  
Arm width 9 7/8"

**DALS00**  
sofa 190

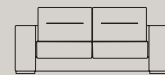

190  
74 3/4"

**DALS01**  
sofa 210

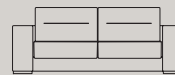

210  
82 5/8"

**DALS02**  
sofa 230

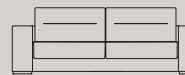

230  
90 1/2"

**DALS03**  
sofa 250

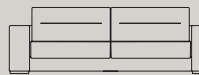

250  
98 3/8"

**DALS04**  
sofa 270

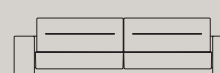

270  
106 1/2"

**DALS05**  
sofa 290

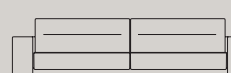

290  
114 1/8"

**DALS06**  
end element 95



95  
37 3/8"

**DALS07**  
end element 105



105  
41 3/8"

**DALS08**  
end element 115



115  
45 1/4"

**DALS09**  
end element 125



125  
49 1/4"

**DALS10**  
end element 135



135  
53 1/8"

**DALS11**  
end element 145

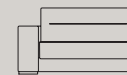

145  
57 1/8"

**DALS12**  
end element 165

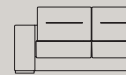

165  
64 7/8"

**DALS13**  
end element 185

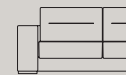

185  
72 7/8"

**DALS14**  
end element 205

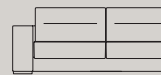

205  
80 3/4"

**DALS15**  
end element 225

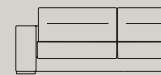

225  
88 5/8"

**DALS16**  
end element 245

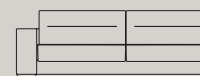

245  
96 1/2"

**DALS17**  
end element 265

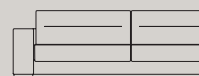

265  
104 3/8"

**DALS18**  
central element 140



140  
55 1/8"

**DALS19**  
central element 160



160  
62 7/8"

**DALS20**  
central element 180

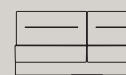

180  
70 7/8"

**DALS21**  
central element 200



200  
78 3/4"

**DALS22**  
central element 220

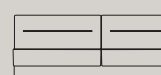

220  
86 5/8"

**DALS23**  
central element 240



240  
94 1/2"

**DALS27**  
central element 140 with ottoman

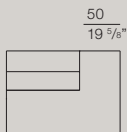

140  
55 1/8"

**DALS28**  
central element 150 with ottoman

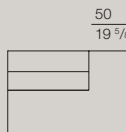

150  
59"

**DALS29**  
central element 160 with ottoman

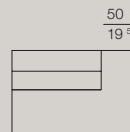

160  
62 7/8"

**DALS30**  
central element 170 with ottoman

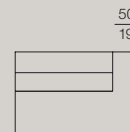

170  
66 7/8"

**DALS24**  
terminal element 215 with ottoman

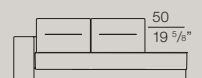

215  
84 3/8"

**DALS25**  
terminal element 235 with ottoman

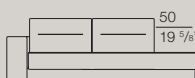

235  
92 1/2"

**DALS26**  
terminal element 255 with ottoman



255  
100 3/8"

**DALS31**  
chaise longue 105 x 175



105  
41 3/8"

**DALS32**  
chaise longue 115 x 175

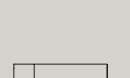

115  
45 1/8"

**DALS37**  
chaise longue 125 x 175

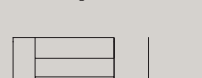

125  
49 1/2"

**DALS38**  
squared element 115 x 115



115  
45 1/4"

**DALS33**  
ottoman 140 x 100



140  
55 1/8"

**DALS34**  
ottoman 100 x 100



100  
39 1/8"

Struttura in legno rivestita in poliuretano espanso indeformabile e vellutino accoppiato. Molleggio a cinghia elastica intrecciata. Imbottitura seduta in piuma d'oca trapuntata con inserto in poliuretano espanso D35. Schienali in piuma d'oca con inserto in poliuretano D30. Piedi in metallo disponibili nella finitura Nickel Nero o in legno nelle tinte Noce e Wengé.

Wooden structure quilted with non-deformable polyurethane with light double velvet cover. Springiness made of Woven elastic belts. Seat Cushion filled with goose feather quilted with D35 polyurethane insert. Back cushions filled with goose feather. Metal feet in black nickel or stained in walnut or wengé tone.

Holzrahmen verkleidet mit formbeständigem Polyurethanschaum verbunden mit Nylonfaser. Federung bestehend aus elastischen verwebten Gurten. Sitzpolsterung aus Gänsedaunen gesteppt mit Kern aus Polyurethanschaum D35. Rückenissen aus Gänsedaunen mit Kern aus Polyurethanschaum D30. Schwarze verchromte Metallfüße oder Holzfüße Nußbaum oder wengé gebeizt.

Structure en bois revêue en polyuréthane expansé indéformable et toile de coton doublé. Suspension ceintures entrelacées. Coussins d'Assise en plume d'oie matelassé avec insert en polyuréthane expansé D35. Coussins Dossier en plume d'oie avec insert en polyuréthane expansé D30. Pieds en métal disponibles en nickel noir ou en bois teinté noyer ou wengé.

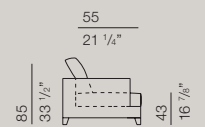

larghezza bracciolo 20 cm  
arm width 7 7/8"

**DOU001**  
sofa 186



186  
73 1/4"

**DOU002**  
sofa 216



216  
85 7/8"

**DOU003**  
sofa 236



236  
92 7/8"

**DOU004**  
sofa 276



276  
108 5/8"

**DOU005**  
end element 93



93  
36 5/8"

**DOU006**  
end element 108



108  
42 1/2"

**DOU007**  
end element 118



118  
46 1/2"

**DOU008**  
end element 138



138  
54 3/8"

**DOU009**  
end element 170



170  
66 7/8"

**DOU010**  
end element 200



200  
78 3/4"

**DOU011**  
end element 220



220  
86 5/8"

**DOU012**  
end element 260



260  
102 3/8"

**DOU013**  
chaise lounge 108 x 175

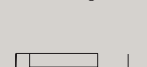

108  
42 1/2"

**DOU014**  
chaise lounge 118 x 175



118  
46 1/2"

**DOU017**  
chaise lounge 108 x 200

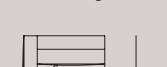

108  
42 1/2"

**DOU015**  
squared element 105 x 105



105  
41 3/8"

**DOU016**  
ottoman 105 x 105



105  
43  
16 7/8" 41 3/8"

Programma di sedute modulari imbottite in larghezze da cm 70, 90 e 110. Struttura in legno massello di faggio rivestita in poliuretano espanso indeformabile e vellutino accoppiato. Molleggio a cinghia elastica intrecciata. Imbottitura seduta in piuma d'oca trapuntata con inserto in poliuretano espanso indeformabile. Imbottitura schienale in piuma d'oca con inserto in poliuretano espanso D25. Su richiesta è possibile inserire un meccanismo per alzare/abbassare gli schienali del divano. Divano completamente smontabile.

Upholstery program of seating and modular elements of cm 70, 90 and 110 width. Structure made of beechwood upholstered with non-deformable polyurethane foam with light double velvet cover. Springiness made of woven elastic belts. Seat cushions filled with goose feather quilted with non-deformable polyurethane foam. Back cushions filled with goose feather with Kg25/m<sup>3</sup> polyurethane insert. On request a lifting mechanism for the back. Totally Knock-Down sofa for an easier delivery and installation.

Modular aufgebautes Sofaprogramm mit Kissenbreiten von 70, 90 und 110 cm. Massiver Buchenholzrahmen verkleidet mit formbeständigem Polyurethanschäum verbunden mit Polyesterfaser. Federung bestehend aus elastischen verwebten Gurten. Sitzpolsterung aus Gänsedaunen mit Kern aus formbeständigem Polyurethanschäum. Rückenpolsterung und -kissen aus Gänsedaunen mit Kern aus Polyurethanschäum D25. Auf Wunsch höhenverstellbare Rückenlehne. Völlig zerlegbares Sofa.

Programme d'assise rembourrées modulables de 70, 90 et 110 cm. Structure en bois massif d'hêtre, revêtue en polyuréthane expansé indéformable, et toile de coton doublé. Suspension ceintures entrelacées. Rembourrage de l'assise en plume d'oie matelassé avec inserts polyuréthane expansé indéformable. Coussins dossier en plume d'oie avec insert en polyuréthane expansé D25. Possibilité de commander pour chaque coussin dossier indépendant, un mécanisme à vérins à gaz permettant le relèvement ou l'abaissement du dossier. Complètement démontable.

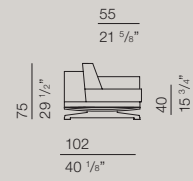

larghezza bracciolo 8 cm  
arm width 3 1/8"

**ET0000**  
armchair 90



90  
35 3/8"

**ET0001**  
sofa 160



160  
62 7/8"

**ET0002**  
sofa 200

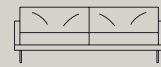

200  
78 3/4"

**ET0003**  
sofa 240

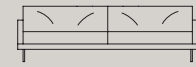

240  
94 1/2"

**ET0042**  
sofa 230

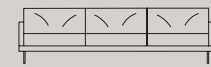

230  
90 1/2"

**ET0043**  
sofa 290



290  
114 1/8"

**ET0044**  
sofa 350



350  
137 29/32"

**ET0004**  
end element with ottoman 223



223  
87 3/4"

**ET0005**  
end element with ottoman 263



263  
103 1/2"

**ET0006**  
end element 80



80  
31 1/2"

**ET0007**  
end element 100



100  
39 3/8"

**ET0008**  
end element 120



120  
47 1/4"

**ET0009**  
end element 153



153  
60 1/4"

**ET0010**  
end element 193

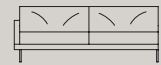

193  
75 7/8"

**ET0011**  
end element 233

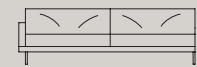

233  
91 3/4"

**ET0045**  
end element 223



223  
87 3/4"

**ET0046**  
end element 283



283  
111 3/8"

**ET0047**  
end element 343

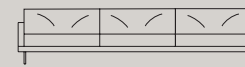

343  
135 1/32"

**ET0012**  
squared element 103 x 183

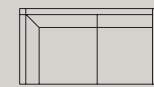

183  
72"

**ET0013**  
squared element 103 x 203



203  
79 7/8"

**ET0014**  
chaise longue 81 x 155

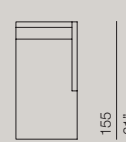

81  
31 7/8"

**ET0015**  
chaise longue 101 x 175

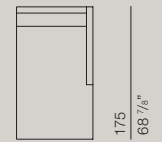

101  
39 3/4"

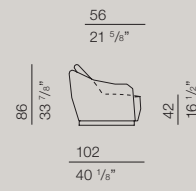

larghezza bracciolo 13 cm  
arm width 5 1/8"

**KYT000**  
sofa 190



190  
74 3/4"

**KYT001**  
sofa 210



210  
82 5/8"

**KYT002**  
sofa 230



230  
90 1/2"

**KYT003**  
sofa 250



250  
98 3/8"

**KYT004**  
sofa 270



270  
106 1/4"

**ET0033**  
squared element 103 x 103



103  
40 1/2"

**ET0034**  
squared element with ottoman 135 x 103

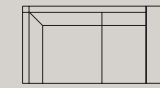

235  
92 1/2"

**ET0048**  
squared element with ottoman 255 x 103

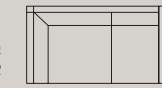

255  
100 3/8"

**ET0049**  
squared element with ottoman 275 x 103

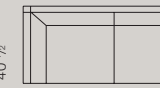

275  
108 1/4"

**ET0035**  
squared element with leather top 235 x 103



235  
92 1/2"

**ET0050**  
squared element with leather top 255 x 103

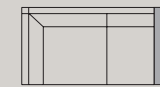

255  
100 3/8"

**ET0051**  
squared element with leather top 275 x 103

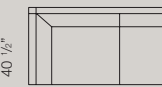

275  
108 1/4"

**ET0038**  
ottoman 103 x 70



103  
40 1/2"

**ET0039**  
ottoman 103 x 103



103  
40 1/2"

**ET0040**  
bench 140 made by two seat of 70

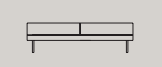

140  
55 1/8"

**ET0041**  
bench 140 made by one seat of 70 and one leather top of 70

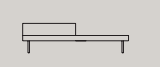

140  
55 1/8"

KYOTO DESIGN GIUSEPPE MANZONI

Struttura in legno rivestita in poliuretano espanso D40. Seduta in poliuretano espanso D40 rivestito in vellutino accoppiato. Schienali in piuma. Basamento rivestito in lamina metallica, disponibile nelle finiture Cromo nero o Ottone.

Wooden frame upholstered with kg.40/m<sup>3</sup> polyurethane. Seat cushions in goose feather with a light double velvet cover. Back cushions in goose feather. Metal plated base, available either in black chrome or in brass finish.

Holzrahmen verkleidet mit Polyurethanschäum D40. Sitz aus Polyurethanschäum D40 verbunden mit Polyesterfaser. Rücken aus Daunen. Gestell verkleidet mit Metallfolie, schwarz verchromt oder Blech.

Structure en bois, revêtue en polyuréthane expansé D40. Assise en polyuréthane expansé D40 revêtue en toile de coton doublé. Dossier en plume. Base revêtue en lamifié métallique, disponible aussi en noir chromé ou laiton.



Struttura in legno rivestita in poliuretano espanso indeformabile e vellutino accoppiato. Molleggio a cinghia elastica intrecciata. Imbottitura seduta in poliuretano espanso D30 + Piuma d'oca. Schienali in poliuretano espanso D18 + Piuma d'oca. Su richiesta è possibile inserire sotto le sedute un meccanismo dotato di un carrello che permette alle stesse di scorrere ed avanzare di 20 cm.

Wooden frame upholstered with non-deformable polyurethane foam covered with a light double velvet. Springiness made of woven elastic belts, seat in Kg30/m3 polyurethane foam + goose feathers. Back in Kg18/m3 polyurethane foam + goose feathers. On request a possible sliding mechanism for the seats to become cm 20 deeper.

Holzrahmen verkleidet mit formbeständigem Polyurethanschaum verbunden mit Baumwolle-Bezug. Federung bestehend aus elastischen verwebten Gurten. Sitzpolsterung aus Polyurethanschaum D30 + Gänsedaunen. Rückenkissen aus Polyurethanschaum D18 + Gänsedaunen. Auf Wunsch ist es möglich, den jeweiligen Sitzkissen eine Mechanik zu integrieren, mit dessen Hilfe der Sitz 20 cm vorschiebbar ist.

Structure en bois revêtu en polyuréthane expansé indéformable et toile de coton doublé. Suspension ceintures entrelacées. Rembourrage de l'assise en Polyuréthane expansé D30 + plume d'oie. Dossier en Polyuréthane expansé D18 + plume d'oie. Sur demande, c'est possible d'insérer au-dessous de la structure de l'assise un mécanisme équipé d'un chariot qui permet à l'assise de glisser en avant pour 20cm.

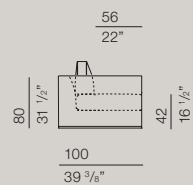

larghezza bracciolo 13 cm  
arm width 9 1/8"

**LOND00**  
armchair 110



110  
43 1/4"

**LOND01**  
armchair big 130

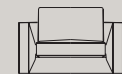

130  
51 1/8"

**LOND02**  
sofa 170



170  
66 7/8"

**LOND03**  
sofa 190



190  
74 3/4"

**LOND04**  
sofa 210



210  
82 5/8"

**LOND05**  
sofa 240



240  
94 1/2"

**LOND06**  
sofa 260



260  
102"

**LOND07**  
sofa 290

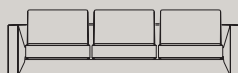

290  
114 1/8"

**LOND08**  
end element 85



85  
33 1/2"

**LOND09**  
end element 95



95  
37 3/8"

**LOND10**  
end element 105



105  
41 3/8"

**LOND11**  
end element 120



120  
47 1/4"

**LOND12**  
end element 130



130  
51 1/8"

**LOND13**  
end element 145



145  
67 1/8"

**LOND14**  
end element 165



165  
64 7/8"

**LOND15**  
end element 185



185  
72 7/8"

**LOND16**  
end element 215



215  
84 5/8"

**LOND17**  
end element 235



235  
92 1/2"

**LOND18**  
end element 265



265  
104 3/8"

**LOND29**  
end element 205  
with ottoman



205  
80 3/4"

**LOND30**  
end element 225  
with ottoman



225  
88 5/8"

**LOND31**  
end element 255  
with ottoman



255  
100 3/8"

**LOND32**  
end element 275  
with ottoman



275  
108 1/4"

**LOND19**  
central element 125



125  
49 1/2"

**LOND20**  
central element 145

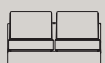

145  
57 1/8"

**LOND21**  
central element 165



165  
64 7/8"

**LOND22**  
central element 195



195  
76 1/4"

**LOND23**  
central element 215



215  
84 5/8"

**LOND24**  
central element 240



240  
94 1/2"

**LOND25**  
central element 240  
with ottoman



240  
94 1/2"

**LOND26**  
central element 260  
with ottoman



260  
102 3/8"

**LOND27**  
central element 145  
with ottoman

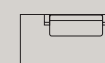

145  
57 1/8"

**LOND28**  
central element 165  
with ottoman

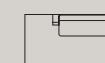

165  
64 7/8"

**LOND33**  
chaise longue 95 x 175

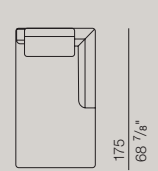

95  
37 3/8"

**LOND34**  
chaise longue 120 x 175

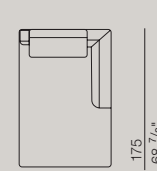

120  
47 1/4"

**LOND35**  
ottoman 100 x 100

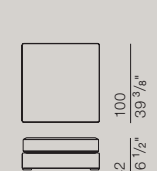

100  
39 3/8"

**LOND36**  
ottoman 100 x 140

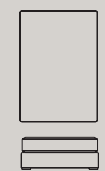

100  
39 3/8"

Struttura in legno rivestita in poliuretano espanso indeformabile e vellutino accoppiato. Molleggio a cinghia elastica intrecciata. Imbottitura seduta in espanso D35 + Piuma d'oca. Schienali in piuma con inserto in espanso D21. Piedino di serie in legno, disponibile nella tinta wengé o laccato nero. Divano completamente smontabile.

Wooden structure quilted with non-deformable polyurethane and a light double velvet cover. Springiness made of woven elastic belts, seat in kg35/m3 polyurethane foam + goose feather. Back in goose feather with a Kg21/m3 polyurethane insert. Standard wooden feet in wengé stain or black lacquer. Totally Knock-down sofa for an easier delivery and installation.

Holzrahmen verkleidet mit formbeständigem Polyurethanschaum verbunden mit Nylonfaser. Federung bestehend aus elastischen verwebten Gurten. Sitzkissen aus D35 Polyurethanschaum + Gänsedaunen. Rückenissen aus Gänsedaunen mit Kern aus D21 Polyurethanschaum. Standardfüße aus Holz, entweder wengé gebeizt oder schwarz lackiert. Völlig zerlegbares Sofa.

Structure en bois revêtu en polyuréthane expansé indéformable et toile de coton doublé. Suspension ceintures entrelacées. Rembourrage de l'assise en Polyuréthane expansé D35 + plume d'oie. Dossier en Polyuréthane expansé D21. Pieds en bois, teinte wengé ou noir laqué. Complètement démontable.

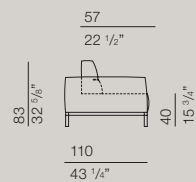

larghezza bracciolo 24 cm  
arm width 9 1/2"

**MANH000**  
sofa 190



190  
74 3/4"

**MANH001**  
sofa 230



230  
90 1/2"

**MANH002**  
sofa 250



250  
98 3/8"

**MANH003**  
sofa 290



290  
114 1/8"

**MANH004**  
end element 165



165  
64 7/8"

**MANH005**  
end element 205



205  
80 3/4"

**MANH006**  
end element 225



225  
88 3/8"

**MANH007**  
end element 265



265  
104 3/8"

**MANH012**  
chaise longue 115 x 170

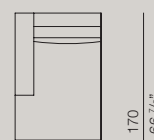

115  
45 1/4"

170  
66 7/8"

**MANH013**  
chaise longue 125 x 170

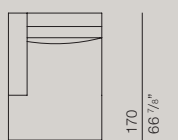

125  
49 1/4"

170  
66 7/8"

**MANH014**  
ottoman 100 x 100

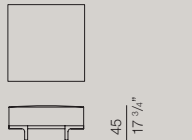

100  
39 3/8"

45  
17 3/4"

**MANH015**  
ottoman 100 x 140

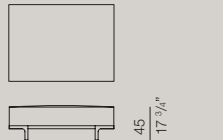

140  
55 1/8"

45  
17 3/4"

Struttura in legno rivestita in poliuretano espanso indeformabile e vellutino accoppiato. Molleggio a cinghia elastica intrecciata. Imbottitura seduta in piuma d'oca trapuntata con inserto in poliuretano espanso D35 indeformabile. Imbottitura schienale in piuma d'oca con inserto in poliuretano espanso D22. Piedino in legno disponibile nelle tinte Rovere sbiancato, Noce o Wengé, oppure in metallo nella finitura cromo lucido. Disponibile nella versione Mr Floyd 100 con profondità ridotta a 100 cm.

Wooden structure with non-deformable polyurethane foam with a light double velvet cover. Springiness made of woven elastic belts. Seat cushion in goose feather with a non-deformable Kg35/m3 polyurethane foam insert. Back in goose feathers with Kg22/m3 foam insert. Wooden feet in white-washed oak, walnut and wengé finish. Metal feet in glossy chrome. Mr FLOYD 100 refers to a shorter depth of cm 100.

Holzrahmen verkleidet mit formbeständigem Polyurethanschaum verbunden mit Polyesterfaser. Federung bestehend aus elastischen verwebten Gurten. Sitzpolsterung aus Gänsedaunen mit Kern aus formbeständigem D35 Polyurethanschaum. Rückenpolsterung und Rückenissen aus Gänsedaunen mit Kern aus D22 Polyurethanschaum. Standardholzfüße in den folgenden Ausführungen erhältlich: geweißter Eiche, Nussbaum oder Wengé gebeizt oder verchromte Metall. Eine Version Mr. Floyd 100, mit reduzierter Tiefe cm 100, ist verfügbar.

Structure en bois revêtues en polyuréthane expansé indéformable et toile en coton doublé. Suspensions ceintures entrelacées. Coussins d'Assise en plume d'oie matelassé avec insert en polyuréthane expansé D35 indéformable. Coussin Dossier en plume d'oie avec insert en polyuréthane expansé D22. Standard pieds en bois dans les teinture Mélèze blanchie ou Wengé. Disponible aussi en métal chromé. Disponible aussi avec profondeur 100 cm.

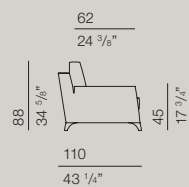

larghezza bracciolo 18 cm  
arm width 7 1/8"

**MR0000**  
armchair 101



101  
39 3/4"

**MR0001**  
sofa 170

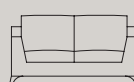

170  
66 7/8"

**MR0002**  
sofa 200

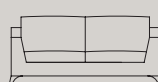

200  
78 3/4"

**MR0003**  
sofa 220

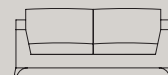

220  
86 3/8"

**MR0004**  
sofa 235



235  
92 1/2"

**MR0005**  
sofa 282

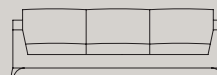

282  
111"

**MR0006**  
end element 152



152  
59 7/8"

**MR0007**  
end element 182

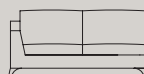

182  
71 3/8"

**MR0008**  
end element 202



202  
79 1/2"

**MR0009**  
end element 217

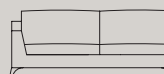

217  
85 3/8"

**MR0010**  
end element 264

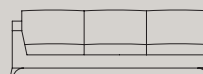

264  
103 7/8"

**MR0016**  
end element 85



85  
33 1/2"

**MR0017**  
end element 100



100  
39 3/8"

**MR0018**  
end element 110



110  
43 1/4"

**MR0019**  
end element 120



120  
47 1/4"

**MR0011**  
squared element 106 x 106

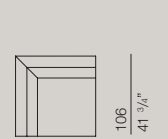

106  
41 3/4"

106  
41 3/4"

**MR0012**  
chaise longue 98 x 160

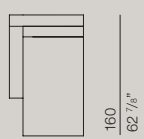

98  
38 3/8"

160  
62 7/8"

**MR0013**  
chaise longue 108 x 160

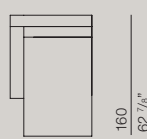

108  
42 1/2"

160  
62 7/8"

**MR0015**  
ottoman 80 x 80

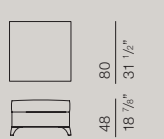

80  
31 1/2"

80  
31 1/2"

Programma di sedute, elementi componibili e divani rivolto a soddisfare ogni esigenza d'arredo. Struttura portante in legno imbottita in poliuretano espanso a quote differenziate e vellutino. Sedute in poliuretano espanso D35 + falda morbida in resinato, fodera in cotone 100% a tenuta di piuma. Schienale in piuma d'oca con inserto in poliuretano espanso D21, federati in cotone 100% a tenuta di piuma. Piedini e cricchetti metallici finitura Nickel nero. Mensole e pedane disponibili in legno nella finitura noce canaletto, o in MDF disponibili in tutti i colori RAL. Mensole inclinabili e regolabili in altezza mediante un meccanismo push-pull. La pedana permette ai vari elementi imbottiti di muoversi e ruotare. Divano completamente smontabile.

Collection of seatings, modular elements and free-standing sofas to meet any customer's requirement. Wooden frame and upholstery in polyurethane foam of different space weight for a better comfort with a light double velvet cover. Seat cushions in kg 35/m³ polyurethane foam + soft resin layer; covered with a 100% cotton fabric encasing the feather inside. Back cushions in feather with polyurethane foam insert, covered with a 100% cotton fabric encasing the feather. Metal feet in black Nickel. Wooden shelves and inbetween base in Canaletto walnut finish or lacquered in any RAL colour. Back shelves are reclinable and adjustable in H by a push-pull mechanism. The wooden base between seat elements slides and revolves. Totally Knock-Down sofa for an easier delivery and installation.

Vielseitiges Sofaprogramm für individuelle Einrichtungsgestaltung. Tragender Holzrahmen verkleidet mit Polyurethanschäum in angepassten Dichten mit Baumwolle-Bezug, Sitzpolsterung aus D35 Polyurethanschäum + weicher Harzschicht, komplett im Baumwollinlett. Rückenkissen aus Gänsedaunen mit Kern aus D21 Polyurethanschäum, komplett im Baumwollinlett. Schwarze Metallfüße. Neigbare und durch push-pull Mechanismus höhenverstellbare Standardholzurückstütze aus Canaletto Nussbaum oder auf Wunsch nach alle RAL Farben. Völlig zerlegbares Sofa.

Programme d'assises, d'éléments modulaires et de canapés conçus pour satisfaire tous les besoins en matière d'ameublement. Structure portante en bois revêtue en polyuréthane expansé avec différente masse volumique + toile en coton. Assise en polyuréthane expansé D35 + feuille résine, doublure en coton 100% anti plume-déborderement. Dossier en plume d'oie avec insert en polyuréthane expansé D21, doublure en coton 100% anti plume-déborderement. Pieds et criques en métal, finissage Nickel noir. Etagères et estrades disponibles en bois teinté noyer Canaletto ou en MDF dans toutes les couleurs RAL. Etagères inclinables et réglables en hauteur grâce à un système push-pull. L'estrade permet aux éléments rembourrés de se déplacer et pivoter. Complètement démontable.

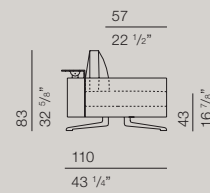

**MM0000**  
sofa 216

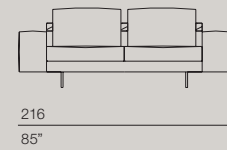

**MM0001**  
sofa 246

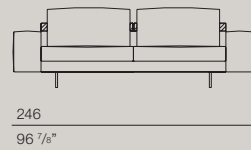

**MM0002**  
sofa 276

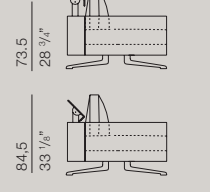
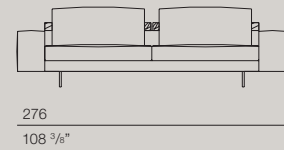

**MM0003**  
central element 110

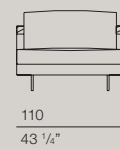

**MM0004**  
central element 160

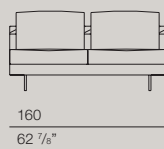

**MM0005**  
central element 190

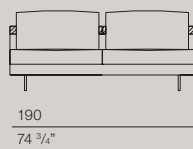

**MM0006**  
central element 220

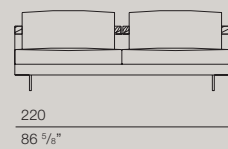

larghezza bracciolo 28 cm  
arm width 11"

**MM0007**  
chaise longue 168 x 80

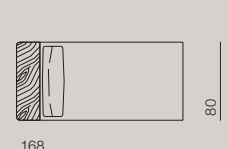

**MM0008**  
chaise longue 168 x 100

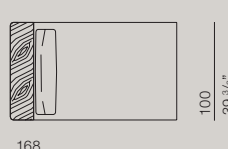

**MM0009**  
squared element dx 168 x 110

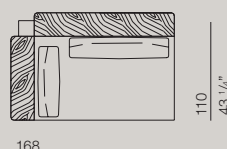

**MM0010**  
squared element sx 168 x 110

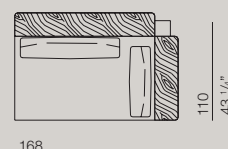

**MM0011**  
ottoman 102 x 102

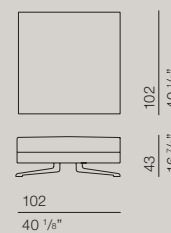

**MM0012**  
upholstered arm



**MM0013**  
platform



**MM0014**  
slim platform



Serie di poltrone e divani lineari. Struttura in legno, rivestita in poliuretano espanso D40 e vellutino 200 gr accoppiato a resinato. Molleggio a cinghia elastica intrecciata. Imbottitura seduta in piuma d'oca etichetta Oro, con inserto Poliuretano D35 e D25 Soft. Imbottitura schienale in piuma d'oca. Piede in legno, disponibile nelle tinte Noce o Wengé.

Armchair and sofas program. Wooden frame and D40 polyurethane foam with 200gr. Light double velvet cover. Springiness made of woven elastic belts. Seat cushions in goose feather with D35 and D25SOFT polyurethane foam. Back cushions in goose feather. Wooden feet available in wenge and walnut stain.

Holzrahmen verkleidet mit D40 Polyurethanschäum und 200gr. Nylonfaser verbunden mit Harz Federung bestehend aus elastischen verwebten Gurten. Sitzpolsterung aus "Gold Label" Gänsedaunen mit Kern aus D35 + D25 soft. Rückenpolsterung aus Gänsedaunen. Holzfüße entweder Nussbaum oder Wengé gebeizt.

Collection de Fauteuils et Canapés Linéaires. Structure en bois revêtue en polyuréthane expansé D40 et toile de coton 200gr doublé avec feuille résine. Suspensions avec ceintures entrelacées. Coussins d'Assise en plume d'oie étiquette d'or avec insert en Polyuréthane D35 et D25 Soft. Coussins Dossier en plume d'oie. Pied en bois, disponibles dans les teintures Noyer ou Wengé.

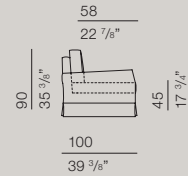

**MUR000**  
armchair 104

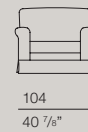

**MUR001**  
sofa 184

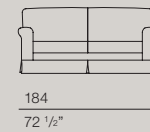

**MUR002**  
sofa 204

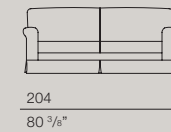

larghezza bracciolo 22 cm  
arm width 8 7/8"

**MUR003**  
sofa 224

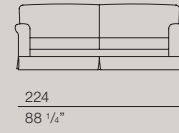

**MUR004**  
sofa 244

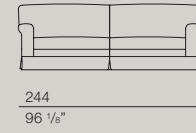

**MUR005**  
sofa 284

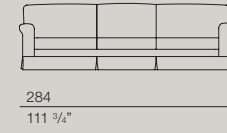

Struttura a pozzetto in legno rivestita in poliuretano espanso a quote differenziate. Seduta con inserto in poliuretano espanso D35 + Piuma. Schienali in Piuma. Piedino in legno disponibile nelle tinte noce o wengé.

Wooden frame with upholstery in polyurethane foam of different space weight. Seat cushions made of D35 polyurethane + goose feather, back cushions in goose feather. Wooden feet in walnut or wenge finish.

Holzrahmen verkleidet mit Polyurethanschäum in angepassten Dichten. Sitz aus Gänsedaunen mit Kern aus D35 PU-Schaum. Rückenkissen aus Gänsedaunen. Holzfüße entweder Nussbaum oder Wengé gebeizt.

Structure en bois revêtue avec polyuréthane expansé avec différente masse volumique. Assise avec insert en polyuréthane expansé D35 + plume. Coussins dossier en plume. Pied en bois teinté noyer ou wenge.

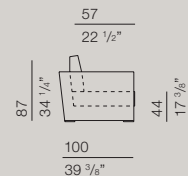

**QUEN000**  
armchair 110



**QUEN001**  
sofa 150

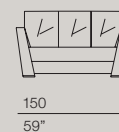

**QUEN002**  
sofa 175

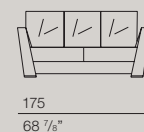

**QUEN003**  
sofa 220

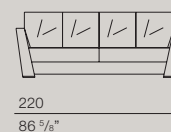

**QUEN004**  
sofa 268

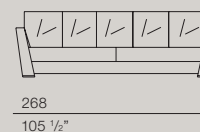

larghezza bracciolo 15 cm  
arm width 5 7/8"

**QUEN005**  
sofa 310

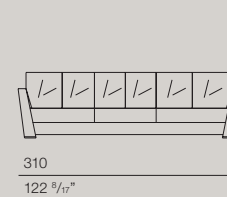

**QUEN012**  
ottoman 100 x 100

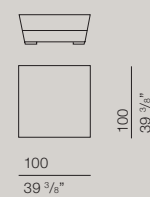

Programma completo di elementi componibili, composto da elementi di seduta, schienali imbottiti, cuscini di schienale e strutture di supporto in ferro e/o rivestite in cuoio da mixare e combinare tra loro. Sedute con struttura in legno, disponibili nelle profondità 100 cm e 120 cm, rivestite in poliuretano espanso D21 con trapuntino superiore in piuma d'oca. Schienale imbottito portante: base in legno e poliuretano espanso D35, con supporto antiscivolo. Cuscino schienale: piuma d'oca. Cuscino bracciolo: poliuretano espanso D21 con anima portante in lamiera di ferro mm 4. Schienale: lamiera di ferro mm 4 verniciata bianca/nera/grigio antracite opaco e/o rivestita in cuoio. Completano la collezione la libreria ed il server.

Upholstery program of modular units consisting of single seat elements, back cushions and free-standing iron back support which are available in leather cover too. Seat with wooden structure available in cm 100 and cm 120 depth, padded Kg21/m<sup>3</sup> polyurethane foam and an upper quilt. Back in anti-slip D35 polyurethane foam. Back cushion in goose feather. Armrest cushion: Kg21/m<sup>3</sup> polyurethane foam with mm 4 iron metal core Iron back support, mm 4 available in white / black / dark grey lacquer or in hard-leather cover. Accessories are a side small library and a metal C-shaped stand.

Komplettes Sofaprogramm bestehend aus Einzelmodulen mit Sitzelementen, Rückenkissen und Metallelementen entweder lackiert oder mit Kernlederbezug. Alles ist miteinander kombinierbar. Sitze (100cm oder 120cm tief) mit Holzrahmen verkleidet mit D21 Polyurethanschaum. Polsterung aus PU-Schaum mit angepassten Dichten und obere Schicht aus Gänsedaunen. Tragende Rückenteil: Holzrahmen und D35 PU-Schaum, mit rutschhemmenden Halterung Rückenkissen: Gänsedaunen Armlehnkissen: aus D21 Polyurethanschaum mit 4,00mm dicker tragender Eisenunterlage. Rückenlehne: 4,00mm dickes Eisenblech entweder matt weiß, schwarz, anthrazit-grau lackiert oder mit Kernlederbezug. Ergänzt wird die Kollektion durch Bücherregal und Ablagetisch.

Programme complet d'éléments composables, composé par assises, dossiers rembourrés, coussins dossier et structures de support en fer ou en bois revêtues en cuir. Assises avec structure en bois, profondeurs 100cm et 120cm, revêtues en poluréthane expansé D21 matelassé avec plumes en surface. Dossier portant rembourré : basement en bois et polyuréthane expansé D35, avec support antidérapant Coussin dossier: Plume d'oie Coussin accoudoir: Polyuréthane expansé D21 avec structure intérieure portante en tôle en fer mm.4 Dossier: tôle en fer mm.4 polis blanc/noir/gris anthracite et/ou revêtue en cuir. Etagère et petite table complètent la collection.

**SH0000**  
element 100 x 100

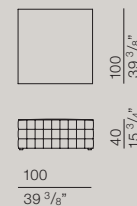

**SH0001**  
element 100 x 130



**SH0018**  
element 100 x 150

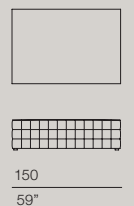

**SH0002**  
element 170

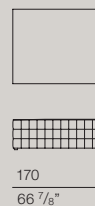

**SH0003**  
element 190

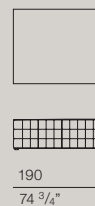

**SH0004**  
element 210

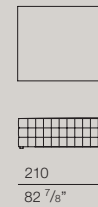

**SH0005**  
element 230

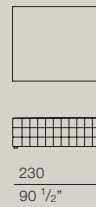

**SH0006**  
element 250

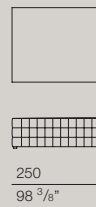

**SH0007**  
element 280

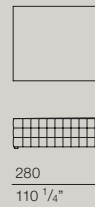

**SH0020**  
element 120 x 120

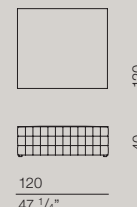

**SH0021**  
element 150 x 120

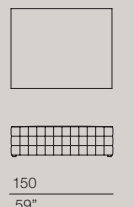

**SH0022**  
element 170 x 120

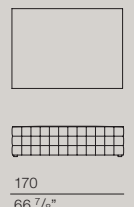

**SH0023**  
element 190 x 120

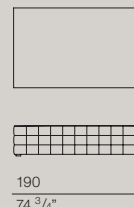

**SH0024**  
element 210 x 120

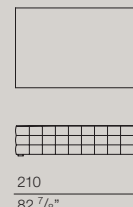

**SH0025**  
element 230 x 120

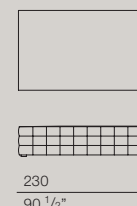

**SH0026**  
element 250 x 120

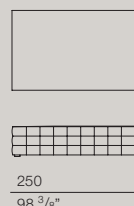

**SH0027**  
element 280 x 120

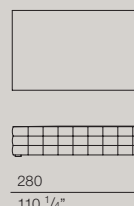

**SH0008**  
back cushion

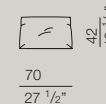

**SH0009**  
back cushion

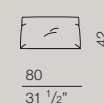

**SH0010**  
back cushion

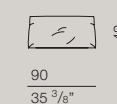

**SH0011**  
two back cushions slim

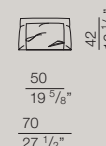

**SH0012**  
two back cushions slim

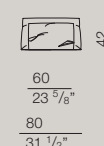

**SH0013**  
two back cushions slim

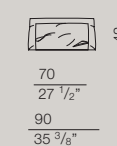

**SH0014**  
iron backrest element



**SH0015**  
server



**SH0016**  
mini library



**SH0017**  
arm cushion



**SH0028**  
self standing backrest 70 cm

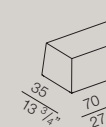

**SH0029**  
self standing backrest 80 cm

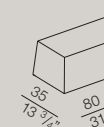

**SH0030**  
self standing backrest 90 cm

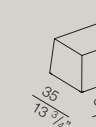

**SH0031**  
cushion 60 cm for self standing backrest



**SH0032**  
cushion 70 cm for self standing backrest

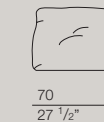

TOKYO DESIGN GIUSEPPE MANZONI

Struttura in legno rivestita in poliuretano espanso indeformabile e vellutino accoppiato. Molleggio a cinghia elastica intrecciata, imbottitura seduta in espanso D40. Schienali in espanso D18. Piedino in legno disponibile nella tinta wengé o in metallo nella finitura Nickel nero.

Wooden frame and non-deformable polyurethane foam with a light double velvet cover. Seat with woven elastic belt and padding in Kg40/m3 polyurethane foam. Back in kg18/m3 polyurethane foam. Wooden feet available in wengé finish, metal feet in black nickel.

Holzrahmen verkleidet mit formbeständigem Polyurethanschaum bezogen mit Polyesterfasergewebe. Unterpösterung aus verwobenen elastischen Gummigurten. Sitzkissen aus D40 Polyurethanschaum. Rückenkissen aus D18 Polyurethanschaum. Wengé gebeizte Standardholzfüße. Auf Wunsch schwarz verchromte Metallfüße.

Structure en bois revêtu en polyuréthane expansé indéformable et toile de coton doublé. Suspension ceintures entrelacées. Assise en polyuréthane expansé D40. Dossier en polyurthane expansé D18. Pieds en bois, teinte wengé ou finissage Nickel noir.

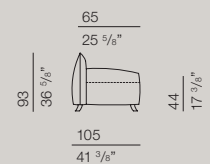

**TOKY00**  
armchair 105

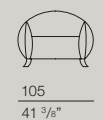

**TOKY01**  
armchair big 115

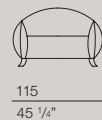

**TOKY02**  
sofa 200

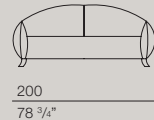

**TOKY03**  
sofa 220

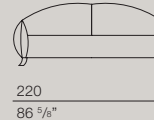

**TOKY04**  
sofa 240

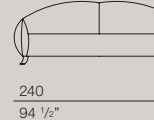

larghezza bracciolo 20 cm  
arm width 7 7/8"

**TOKY05**  
sofa 280

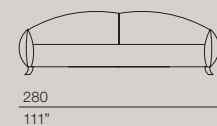

**TOKY12**  
dormeuse 105 x 180 dx

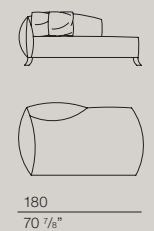

**TOKY15**  
dormeuse 105 x 180 sx

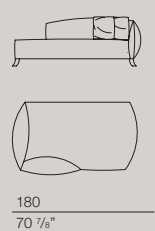

**TOKY14**  
dormeuse 105 x 210 dx

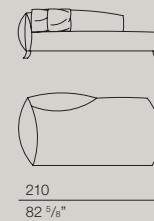

**TOKY16**  
dormeuse 105 x 210 sx

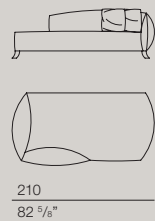

**TOKY13**  
ottoman 90 x 130

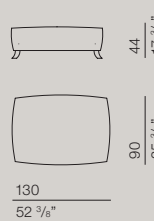

**TOKY17**  
bench 50 x 140

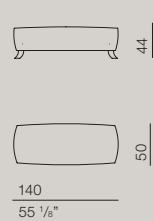

CAROL DESIGN GIUSEPPE MANZONI

Struttura in legno rivestita in poliuretano espanso D40. Schienale in poliuretano espanso D40 rivestito in vellutino accoppiato. Seduta in poliuretano espanso D40 rivestita con foderina cotone 100%. Basamento girevole a 4 razze, in metallo lucidato bronzo.

Wooden frame upholstered with D40 polyurethane foam. Back in D40 polyurethane foam covered with cotton double light velvet fabric. Seat in D40 polyurethane foam with 100% cotton cover. Swivel metal base in bronze finish.

H o l z r a h m e n m i t Polyurethanschaum D40 verkleidet. Rücken aus D40 Polyurethanschaum, mit Baumwollnesel bezogen. Sitze aus D40 Polyurethanschaum, mit 100% Baumwollfutter bezogen. 4-Radius drehbares Gestell, bronze lackiert Metall.

Structure en bois revêtu en polyurethane expansive D40. Dossier en polyuréthane expansé D40 revêtu avec toile de coton doublé. Assise en polyuréthane expansé D40 revêtu avec toile de coton 100%. Base pivotante avec 4 rayons en métal poli bronze.

**CRL000**  
carol armchair H80

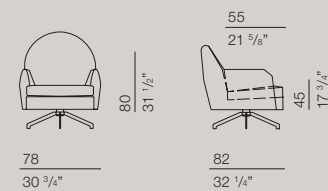

larghezza bracciolo 13 cm  
arm width 5 1/8"

**CRL001**  
carol A armchair H90

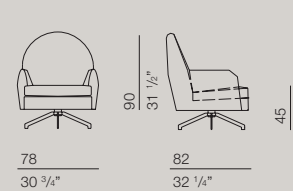

larghezza bracciolo 13 cm  
arm width 5 1/8"

**CRL002**  
ottoman 60x46

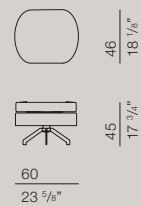

DOVEVUOI DESIGN STUDIO RES

Struttura in ferro rivestita in poliuretano espanso D/35. Cuscino seduta in poliuretano D/30. Gamba cromata lucida, ruote antigraffio. Disponibile nelle versioni Rivestimento Corto e Rivestimento Lungo.

Frame in metal covered in D35 polyurethane. Seat cushion in D30 polyurethane foam. Chromed finish legs with anti-scratch wheels. Available in 2 cover versions: short or to the floor.

Metallrahmen mit Polyurethanschaum D35 verkleidet. Sitzkissen aus Polyurethan D30. Verchromte Beine, auf Rollen. Verfügbar mit beiden langen oder kurzen Hussen.

Structure en fer revêtu en polyurethane expansé D35. Assise en polyuréthane D30. Pieds métal chromé brillant. Roulettes anti-égratiture. Disponible dans la version Revêtement Court et Revêtement Longue.

**DVC000**  
armchair short skirt

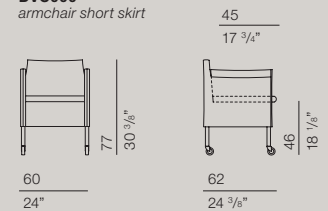

larghezza bracciolo 7 cm  
arm width 2 3/4"

**DVL000**  
armchair long skirt

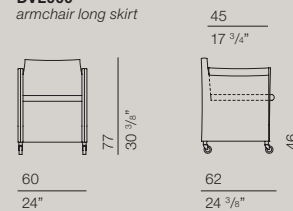

larghezza bracciolo 7 cm  
arm width 2 3/4"

**GRACE** DESIGN GIUSEPPE MANZONI

Struttura in legno rivestita in poliuretano espanso D40. Schienale in poliuretano espanso D25 rivestito in vellutino accoppiato. Seduta in poliuretano espanso D35 rivestita in vellutino accoppiato. Piede anteriore in frassino tinto wengé, piede posteriore rivestito. Prodotto non sfoderabile.

Wooden frame with D/40 polyurethane foam. Back in D/25 polyurethane covered in double light velvet fabric. Seat in D/35 polyurethane foam with cotton lining. Front wengé finished feet, dressed back feet. Unremovable cover.

Holzrahmen mit Polyurethanschaum D40 verkleidet. Rücken aus D25 Polyurethanschaum, mit Baumwollnessel bezogen. Sitze aus D35 Polyurethanschaum, mit Baumwollnessel bezogen. Vorderfüße aus Eschenholz, wengefarbig gebeizt. Hinterfüße mit Stoff bezogen. Nicht abnehmbarer Bezug.

Structure en bois revêtu en polyurethane expansé D40. Dossier en polyuréthane expansé D25 revêtu avec toile de coton doublé. Assise en polyuréthane expansé D35 revêtu avec toile de coton doublé. Pied antérieur en frêne tainté wengé, pied postérieure revêtu. Pas dehoussable.

**GRA000**  
armchair

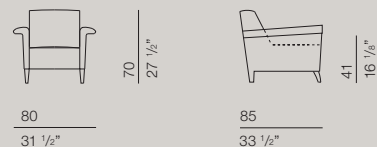

larghezza bracciolo 16 cm  
arm width 6 1/4"

**HAVANA** DESIGN GIUSEPPE MANZONI

Struttura in legno rivestita in poliuretano espanso a quote differenziate. Imbottitura poltrona in espanso D30 e D35 morbido. Piede in legno rivestito in pelle o tessuto, con puntale satinato. Prodotto non sfoderabile.

Wooden frame with polyurethane foam in different space weight. Armchair upholstery in D/30 and soft D/35 foam. Fabric or leather dressed feet in wood with matt metal cap. Covers not removable.

Holzrahmen verkleidet mit Polyurethanschaum mit verschiedenen Dichten. Sesselpolsterung aus Polyurethanschaum D30 und Soft D35 Holzfuß entweder mit Leder oder Stoff bezogen, mit satiniertes Metallspitze. Nicht abnehmbarer Bezug.

Structure en bois revêtu en polyuréthane expansé avec différentes masse volumique. Rembourrage fauteuil en polyuréthane expansé D30 et D35 souple. Pied en bois revêtu en cuir ou tissu, avec pointe brossée. Pas dehoussable.

**HAV001**  
armchair 91

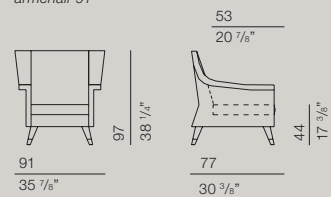

larghezza bracciolo 15 cm  
arm width 5 7/8"

**HAV002**  
ottoman 70 x 50

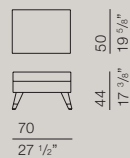

**HAVANA LOUNGE** DESIGN GIUSEPPE MANZONI

Struttura in legno rivestita in poliuretano espanso a quote differenziate. Imbottitura poltrona in espanso D30 e D35 morbido. Piede in legno, disponibile nelle tinte noce, Wengé o tinto al campione. Prodotto non sfoderabile.

Wooden frame with polyurethane foam in different space weight. Armchair upholstery in D/30 and soft D/35 foam. Wooden feet available in walnut and wengé finish. On request finish as per customer's sample is possible. Covers not removable.

Holzrahmen verkleidet mit Polyurethanschaum mit verschiedenen Dichten. Sesselpolsterung aus Polyurethanschaum D30 und Soft D35. Holzfuß, entweder Nussbaum oder Wengé gebeizt. Auf Wunsch auch nach Muster gebeizt. Nicht abnehmbarer Bezug.

Structure en bois revêtu en polyuréthane expansé avec différentes masse volumique. Rembourrage fauteuil en polyuréthane expansé D30 et D35 souple. Pied en bois, disponible dans les teintes noyer, wengé ou customisé. Pas dehoussable.

**HAV005**  
armchair

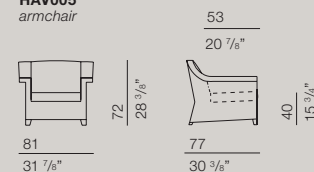

larghezza bracciolo 15 cm  
arm width 5 7/8"

**HAVANA SMALL** DESIGN GIUSEPPE MANZONI

Struttura in legno rivestita in poliuretano espanso a quote differenziate. Imbottitura poltrona in espanso D30 e D35 morbido. Piede in legno, disponibile nelle tinte noce, Wengé o tinto al campione. Prodotto non sfoderabile.

Wooden frame with polyurethane foam in different space weight. Armchair upholstery in D/30 and soft D/35 foam. Wooden feet available in walnut and wengé finish. On request finish as per customer's sample is possible. Covers not removable.

Holzrahmen verkleidet mit Polyurethanschaum mit verschiedenen Dichten. Sesselpolsterung aus Polyurethanschaum D30 und Soft D35. Holzfuß, entweder Nussbaum oder Wengé gebeizt. Auf Wunsch auch nach Muster gebeizt. Nicht abnehmbarer Bezug.

Structure en bois revêtu en polyuréthane expansé avec différentes masse volumique. Rembourrage fauteuil en polyuréthane expansé D30 et D35 souple. Pied en bois, disponible dans les teintes noyer, wengé ou customisé. Pas dehoussable.

**HAV0006**  
armchair

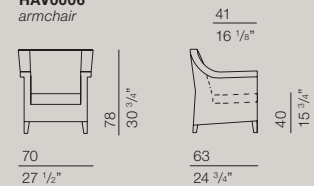

larghezza bracciolo 11 cm  
arm width 4 3/8"

**INGRID** DESIGN GIUSEPPE MANZONI

Struttura in legno rivestita in poliuretano espanso D40. Schienale in poliuretano espanso D40 rivestito in vellutino accoppiato. Seduta in poliuretano espanso D40. Basamento girevole rivestito in lamina metallica, disponibile nelle finiture Cromo nero o Ottone.

Wooden frame upholstered with D/40 polyurethane foam with cotton cover. Seat in D/40 polyurethane foam Metal swivel base in black chrome or brass finish.

Holzrahmen mit Polyurethanschaum D40 verkleidet. Rücken aus D40 Polyurethanschaum, mit Baumwollnessel bezogen. Sitze aus D35 Polyurethanschaum D40. Drehbares Gestell verkleidet mit Metallfolie, schwarz verchromt oder Blech.

Structure en bois revêtu en poliuréthane expansé D40. Dossier en polyuréthane expansé D40 revêtu avec toile de coton doublé. Assise en polyuréthane expansé D40. Base pivotante revêtu en lamifié métallique, disponible aussi en noir chromé ou bronze.

**IGR001**  
armchair H80

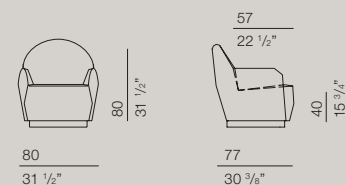

larghezza bracciolo 13 cm  
arm width 5 1/8"

**IGR003**  
armchair H90

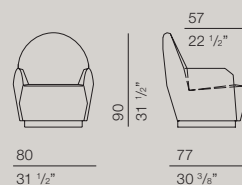

larghezza bracciolo 13 cm  
arm width 5 1/8"

**IGR004**  
ottoman 60 x 46

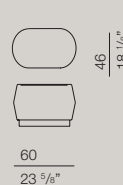

**KIM** DESIGN GIUSEPPE MANZONI

Poltroncina disponibile nelle versioni con e senza bracciolo. Struttura in legno rivestita in poliuretano espanso D35. Schienale in poliuretano espanso D35 rivestito in vellutino accoppiato. Piede in frassino tinto wengé. Prodotto non sfoderabile.

Armchair available in two versions: with and without armrest. Wooden frame padded with D/35 polyurethane foam. Back in D/35 polyurethane foam covered in light velvet double fabric. Beechwood foot, wengé stained. Covers not removable.

Sessel entweder mit oder ohne Armlehnen. Holzrahmen verkleidet mit 35Kg/m³ Polyurethanschaum. Rücken aus 35 Kg/m³ Polyurethanschaum verbunden mit Baumwollnessel. Füße aus Eschenholz, wengé gebeizt. Nicht abnehmbarer Bezug.

Petit fauteuil disponible avec et sans accoudoir. Structure en bois revêtu en poliuréthane expansé D35. Dossier en polyuréthane expansé D35 revêtu avec toile de coton doublé. Pied en frêne teinté wengé. Pas dehoussable.

**KIM000**  
armchair

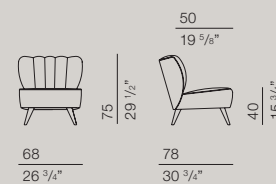

**KIM001**  
armchair

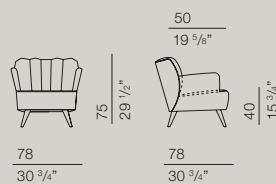

larghezza bracciolo 10 cm  
arm width 3 7/8"

**LÙ** DESIGN GIUSEPPE MANZONI

Struttura in legno rivestita in poliuretano espanso a quote differenziate. Seduta in poliuretano espanso D30 morbido e piuma. Piede in legno, disponibile nelle finiture Wengé o Tinta al campione.

Wooden structure covered with polyurethane foam in different space weight. Seat with D/30 soft polyurethane foam and feather. Wooden feet, finish in Wengé or as per customer's sample

Holzrahmen verkleidet mit PU-Schaum in verschiedenen Dichten. Sitzkissen aus PU-Schaum D30 Soft und Daunen. Holzfuß wengé gebeizt oder nach Muster.

Structure en bois revêtu en polyuréthane expansé avec différente masse volumique. Assise en poliuréthane expansé D30 souple et plumes. Pied en bois, disponible dans les teintes wengé ou customisé.

**LU00000**  
bergere

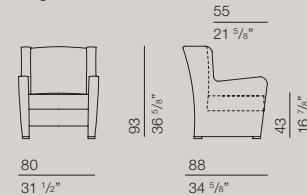

larghezza bracciolo 10 cm  
arm width 3 7/8"

**LU00001**  
ottoman 40 x 84

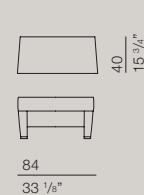

**MARILYN** DESIGN GIUSEPPE MANZONI

Struttura in legno rivestita in poliuretano espanso a quote differenziate. Imbottitura poltrona in espanso. Bracciolo disponibile nelle versioni imbottito, rivestito in cuoio e in noce canaletto. Piede in legno, disponibile nelle finiture Wengé o Tinta al campione. Prodotto non sfoderabile.

Wooden frame covered with polyurethane of different space weight. Upholstery in expanded foam. Armrest in 3 options: upholstered, leather dressed and Canaletto walnut veneer. Cover is fixed.

Holzrahmen verkleidet mit Polyurethanschaum in verschiedenen Dichten. Sesselpolsterung aus Polyurethanschaum. Die Armlehne ist in drei Anfertigungen erhältlich: gepolstert, mit Kernleder bezogen und aus Canaletto Nussbaumholz. Holzfüße, entweder wengé gebeizt oder aus Canaletto Nussbaumholz. Nicht abnehmbarer Bezug.

Structure en bois revêtu en polyuréthane expansé avec différente masse volumique. Rembourrage fauteuil en polyuréthane expansé. Accoudoir disponible en 3 versions : rembourré et revêtu en tissu, revêtu en cuir et en noyer Canaletto. Pied en bois, disponible dans les teintes wengé ou customisé. Pas dehoussable.

**MALY000** armchair upholstered arms  
**MALY001** armchair Canaletto walnut arms  
**MALY002** armchair with arms covered with leather

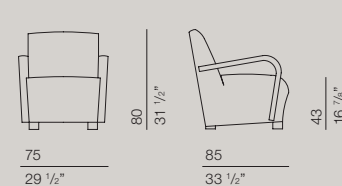

larghezza bracciolo 6 cm  
arm width 2 3/8"

**POUF6050** ottoman 60 x 50

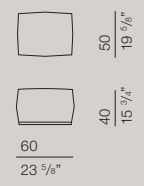

**MARYANNE LOUNGE** DESIGN GIUSEPPE MANZONI

Struttura in legno rivestita in poliuretano espanso a quote differenziate. Imbottitura poltrona in espanso D40, seduta in poliuretano espanso D35 Morbido e piuma. Piede in legno, disponibile nelle finiture Wengé o Rovere sbiancato. Nella confezione in velluto non è prevista la cucitura "con nervetto".

Wooden frame covered with polyurethane foam of different space weight. Armchair upholstery in D/40 polyurethane, seat cushion in D/35 soft polyurethane foam and feather. Wooden feet available in wenge or white-washed oak finish. Pinch stitching not available if in velvet fabric.

Holzrahmen verkleidet mit Polyurethanschäum in verschiedenen Dichten. Sesselpolsterung aus D40 Polyurethanschäum, Sitzkissen aus Soft D35 Polyurethanschäum und Gänsedaunen. Holzfüße, entweder wengé gebeizt oder aus geweißter Eiche. Samtbezüge werden mit Standard-Naht verarbeitet.

Structure en bois revêtue en polyuréthane expansé avec différente masse volumique. Rembourrage fauteuil en polyuréthane expansé D40, assise en poliuréthane expansé D35 souple et plumes. Pied en bois, disponible dans les teintes wengé ou chêne blanchi. En cas de housse en velour c'est possible d'avoir seulement coutures plates.

**MARY006**  
armchair

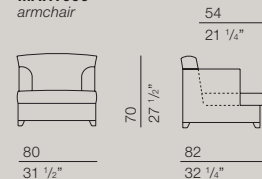

larghezza bracciolo 14 cm  
arm width 5 7/8"

**NICOLE** DESIGN GIUSEPPE MANZONI

Poltroncina disponibile in due diverse altezze. Nicole con schienale H 80 cm e Nicole A con schienale H 93 cm. Struttura in legno rivestita in poliuretano espanso D35 e rivestita in vellutino accoppiato. Cuscino seduta in poliuretano espanso D40 + D35. Schienale con struttura in legno, rivestito in poliuretano espanso D30 + D25. Piede in frassino tinto wengé o noce.

Small armchair available in two different heights: Nicole with Back H. cm 80 cm and Nicole A with Back H. cm 93. Wooden frame upholstered with D/35 polyurethane foam covered with light velvet double fabric. Seat cushion in polyurethane foam Kg 40/m³ + Kg 35/m³. Wooden back upholstered with D/30 + D/25 polyurethane foam. Feet in ashwood, wengé or walnut stained.

Clubsessel verfügbar in zwei verschiedenen Höhen: Nicole mit Rücken 80cm hoch und Nicole A mit Rücken 93cm hoch. Holzrahmen verkleidet mit D35 Polyurethanschäum mit Baumwolle und Polyester Bezug. Sitzkissen aus D40 + D35 Polyurethanschäum. Rücken mit Holzrahmen verkleidet mit D30 + D25 Polyurethanschäum. Eschenholzfüße, entweder Nussbaum oder wengé gebeizt.

Petit fauteuil disponible en 2 hauteurs, Nicole avec dossier H 80cm et Nicole A avec dossier H 93cm. Structure en bois revêtue en poliuréthane expansé D35 et revêtue avec toile de coton doublé. Coussin assise en poliuréthane expansé D40 + D35. Dossier avec structure en bois, revêtu en poliuréthane expansé D30 + D25. Pied en frêne teinte wengé ou noyer.

**NIC000**

nicole armchair H80

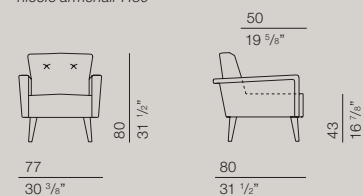

larghezza bracciolo 12 cm  
arm width 4 3/4"

**NIC001**

nicole A armchair H90

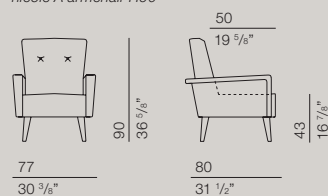

**NINA** DESIGN GIUSEPPE MANZONI

Struttura monoscocca in legno rivestita in poliuretano espanso a quote differenziate D40 e D35. Cuscinetto poggiatesta di serie. Basamento in legno disponibile nelle tinte noce e wengé. Prodotto non sfoderabile.

Wooden frame covered with polyurethane foam of different space weight (D/40 and /35) Backrest small loose cushion included. Wooden base available in walnut and wengé finish. Not removable covers.

Einteiliger Holzrahmen verkleidet mit Polyurethanschäum in D40 bzw. D35 angepassten Dichten. Nierenkissen einschließl. Holzsockel entweder Nussbaum oder wengé gebeizt. Nicht abnehmbarer Bezug.

La Structure est une pièce entière en bois revêtue en polyurethane expansé avec différente masse volumique. Coussin appui rein inclus. Base en bois disponible dans les teintes noyer ou wenge. Pas dehoussable.

**NINA00**

armchair

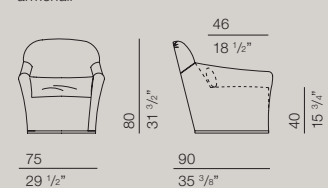

larghezza bracciolo 12 cm  
arm width 4 3/4"

**OLEANDRA** DESIGN GIUSEPPE MANZONI

Struttura in legno rivestita in poliuretano espanso D40. Schienale in poliuretano espanso D40 rivestito in vellutino accoppiato, impreziosito da una trapuntatura con bottoni. Piede in frassino tinto wengé. Prodotto non sfoderabile.

Wooden frame covered with polyurethane foam kg40/m³. Back in polyurethane foam kg40/m³ covered with double light velvet. 2 tufting buttons make it more elegant. Ash wooden feet, wengé stained. Not removable cover.

Holzrahmen mit Polyurethanschäum D40 verkleidet. Rücken aus D40 Polyurethanschäum, mit Baumwollnessel bezogen und durch absteppen wertvoll gemacht. Beine aus Esche gebeizt, wengefarbig. Nicht abnehmbarer Bezug.

Structure en bois revêtue en polyuréthane expansé D40. Dossier en polyuréthane expansé D40 revêtu avec toile de coton doublé, enrichi par une capitonnage avec boutons. Pied en frêne teinte wengé. Pas dehoussable.

**OLR000**

armchair

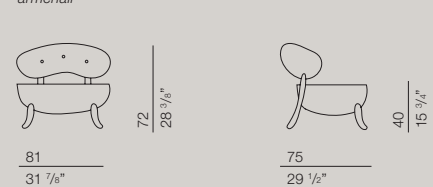



**PROFILE** DESIGN GIUSEPPE MANZONI

Serie di comodini, console e madie caratterizzati da maniglie e basamento in metallo disponibile nelle finiture Cromo nero o Bronzo Spazzolato. Struttura in MDF disponibile nelle finiture impiallacciato noce canaletto o laccato RAL lucido o opaco.

Night-tables, console-tables and cabinets with metal handle and base of design available in black Chrome and sanded Bronze finish. MDF frame in canaletto walnut veneer or in glossy / matt lacquer in any RAL colour tone.

Serie von Nacht-Tischen, Konsole-Tischen und Schränken mit Griffen und Untergestell aus schwarzverchromtem oder bronzegebürstetem Metall. MDF Gestell, Canaletto Nussbaum furniert oder matt/glänzend lackiert in jedem RAL Farbton.

Série de tables de nuit, consoles et armoires avec poignées et socle en métal disponible en chrome noir ou bronze brossé. Structure en MDF disponibles en Noyer canaletto plaqué ou laqué dans toutes colorations RAL soit mat que brillant.

**PFOF007**  
cabinet two doors

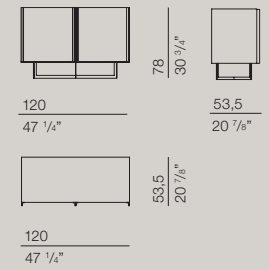

**PFOF008**  
cabinet three doors

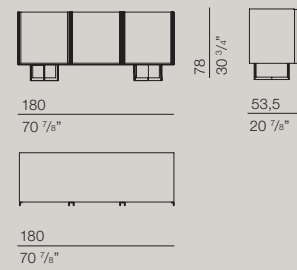

**PFOF009**  
cabinet four doors

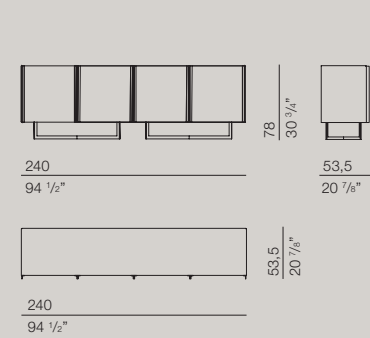

**PFOF010**  
high cabinet four doors

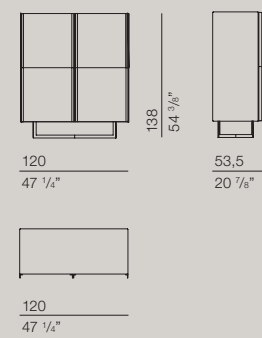

**BLAKE** DESIGN ADRIANO CASTIGLIONI

Serie di tavolini, console e tavoli da pranzo, con basamento in metallo disponibile nelle finiture Nickel nero, Bronzo spazzolato e verniciato opaco peltro. Il piano è disponibile in tutti i colori RAL, oppure in marmo Brown Emperador, Calacatta Oro, Sahara Noir, Saint Laurent, Marron Damasco e Stardust lucido o opaco.

Coffee-tables, console-tables and dining table with metal base available in black nickel, sanded bronze and pewter matt lacquered. Wooden top available in any RAL colour reference lacquer and in Brown Emperador, Calacatta Oro, Sahara Noir, Saint Laurent, Marron Damasco and Stardust marble, in a matt or glossy finish.

Serie von Couchtischen, Konsolen und Eßtische, mit Metallfüße schwarz Nickel, gebürstete Bronze oder Hartzinn mattlackiert. Tischplatte verfügbar entweder aus MDF glänzend oder matt lackiert auf alle RAL Farbe, oder aus Marmor Brown Emperador, Calacatta Oro, Sahara Noir, Saint Laurent, Marron Damasco und Stardust – glänzend oder matt.

Série de petites tables, de consoles et de tables à manger, avec pieds en métal disponible en Nickel noir, bronze brossé ou teint étain mat; top disponible en MDF lacqué brillant ou mat dans toutes couleurs RAL, ou en marbre Brown Emperador, Calacatta Oro, Sahara Noir, Saint Laurent, Marron Damasco et Stardust – brillant ou mat.

**BLA098**  
table 200 x 110 H72

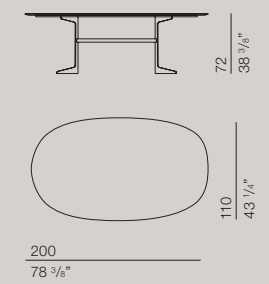

**BLA099**  
table 200 x 110 H72

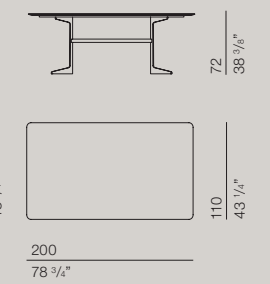

**BLA100**  
table 220 x 110 H72

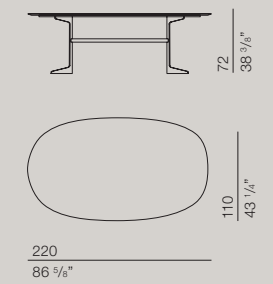

**BLA101**  
table 220 x 110 H72

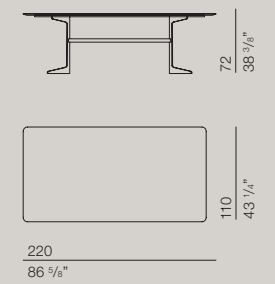

**CI** DESIGN CARLOTTA MANZONI

Serie di tavoli da pranzo, con basamento in metallo verniciato a liquido disponibile nelle finiture Bronzo o Nero Piombo. Il piano bisellato è disponibile in MDF laccato lucido o opaco in tutti i colori RAL, oppure in marmo Brown Emperador, Calacatta Oro, Sahara Noir, Saint Laurent, Marron Damasco e Stardust lucido o opaco.

Dining-tables with metal base available in bronze and lead-grey finish. Bevelled top available in any RAL colour reference lacquer and in Brown Emperador, Calacatta Oro, Sahara Noir, Saint Laurent, Marron Damasco and Stardust marble, in a matt or glossy finish.

Serie von Eßtischen, mit Metallgestell lackiert Bronze oder Blei-schwarz. Tischplatte mit Abschrägen verfügbar entweder aus MDF glänzend oder matt lackiert auf alle RAL Farbe, oder aus Marmor Brown Emperador, Calacatta Oro, Sahara Noir, Saint Laurent, Marron Damasco und Stardust – glänzend oder matt.

Série de tables à manger avec pieds en métal polis bronze ou noir plomb. Top avec biseautage disponible en MDF lacqué brillant ou mat dans toutes couleurs RAL, ou en marbre Brown Emperador, Calacatta Oro, Sahara Noir, Saint Laurent, Marron Damasco et Stardust – brillant ou mat.

**CI006**  
table ø150 H70

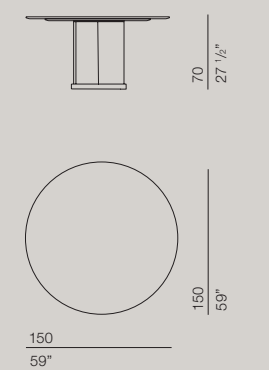

**CI007**  
table ø160 H70

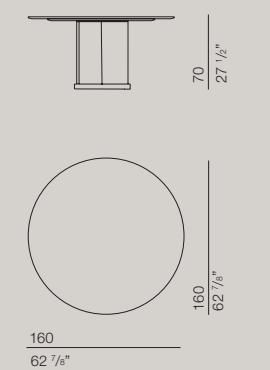

**CI008**  
table ø180 H70

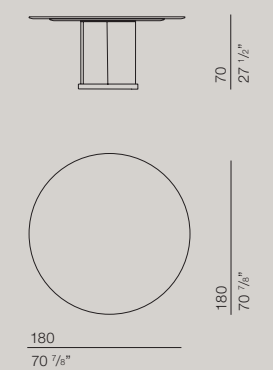

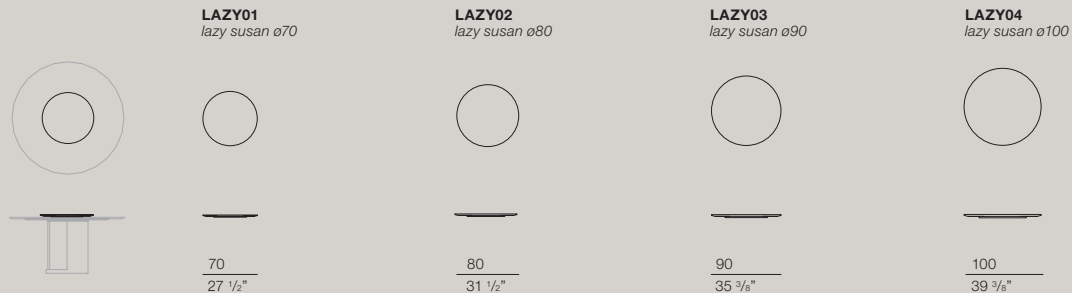

**MONICA** DESIGN GIUSEPPE MANZONI

Sedia con Struttura in legno rivestita in poliuretano espanso D40. Disponibile in due versioni. Basamento in faggio rivestito e basamento in frassino lucidato Wengé. Prodotto non sfoderabile.

Wooden frame upholstered with kg.40/m<sup>3</sup> polyurethane foam. Available in beechwood covered either in leather or in fabric and in ashwood polished in wengé stain. Not removable cover.

Stuhl mit Holzrahmen mit PU-Schaum D40 verkleidet. Verfügbar mit zwei Gestell Finisch: verkleidet Buchenholz oder Eschenholz wengefarbig. Nicht abnehmbare Bezug.

Chaise avec structure en bois revêtue en polyuréthane expansé D40. Disponible dans 2 versions: avec base en hêtre revêtu et avec base en frêne poli wengé. Pas dehoussable.

**MON000**  
base with fabric upholstery  
**MON001**  
polished base



larghezza bracciolo 4 cm  
arm width 1 1/2"

**PEGGY** DESIGN ADRIANO CASTIGLIONI

Sedia con struttura in curvato di compensato di pioppo spessore 15 mm rivestita in poliuretano espanso D40. Struttura portante a crociera in legno laccato nero opaco. Gambe in legno disponibili nella finiture Rovere termocotto o Laccato nero opaco. Prodotto non sfoderabile.

Chair in poplar plywood, 15 mm thick upholstered with D40 polyurethane foam. Wooden load-bearing frame, matt black lacquered. Wooden legs available in smoked oak brown or lacquered. Unremovable cover.

Stuhl mit geformten Pappel-Sperrholzrahmen, mm15, mit PU-Schaum D40 verkleidet. Holzgestell schwarz matt lackiert. Holzfüße auf dunkelbraune Eiche gebeizt oder lackiert.

Chaise avec structure en contreplaqué de peuplier épaisseur mm.15 courbé, revêtu en polyuréthane expansé D40. Structure portante en croix en bois laqué noir mat. Pieds en bois disponibles dans les finitions chêne noirci ou laqué. Pas dehoussable.

**PEG000**  
chair

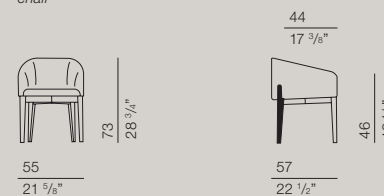

larghezza bracciolo 6 cm  
arm width 2 3/8"

**BIPEDE** DESIGN GIUSEPPE MANZONI

Tavolino con basamento in metallo cromo nero. Piano in legno disponibile in MDF laccato opaco in tutte le tinte RAL, o in MDF impiallacciato noce tinto noce canaletto.

Metal base in black chrome, wooden top available in any RAL colour reference matt lacquer and in walnut veneer, natural stained.

Tisch mit schwarz verchromtem Gestell. Oberfläche in MDF matt in verschiedenen RAL-Tönen erhältlich, oder auch in MDF Nussbaumoptik.

Petite table avec base en métal chromé noir. Top en bois disponible en MDF laqué mat dans toutes les couleurs RAL ou MDF plaqué noyer couleur Canaletto.

**BIPE00**  
low table



**BLAKE** DESIGN ADRIANO CASTIGLIONI

Serie di tavolini e console con basamento in metallo disponibile nelle finiture Nickel nero, Bronzo spazzolato e verniciato opaco petro. Il piano è disponibile in MDF laccato lucido o opaco in tutti i colori RAL, in Rovere termocotto oppure in marmo Brown Emperador, Calacatta Oro, Sahara Noir, Saint Laurent, Marron Damasco e Stardust lucido o opaco.

Coffee-tables, console-tables and dining table with metal base available in black nickel, sanded bronze and pewter matt lacquered. Wooden top available in any RAL colour reference lacquer, in smoked oak brown and in Brown Emperador, Calacatta Oro, Sahara Noir, Saint Laurent, Marron Damasco and Stardust marble, in a matt or glossy finish.

Serie von Couchtischen, Konsolen und Eßtische, mit Metallfüße schwarz Nickel, gebürstete Bronze oder Hartzinn mattlackiert. Tischplatte verfügbar entweder aus MDF glänzend oder matt lackiert auf alle RAL Farbe, auf dunkelbraune Eiche gebeizt oder aus Marmor Brown Emperador, Calacatta Oro, Sahara Noir, Saint Laurent, Marron Damasco und Stardust – glänzend oder matt.

Sérié de petites tables, de consoles et de tables à manger, avec pieds en métal disponible en Nickel noir, bronze brossé ou teint étain mat; top disponible en MDF lacqué brillant ou mat dans toutes couleurs RAL, en bois en chêne noirci ou en marbre Brown Emperador, Calacatta Oro, Sahara Noir, Saint Laurent, Marron Damasco et Stardust – brillant ou mat.

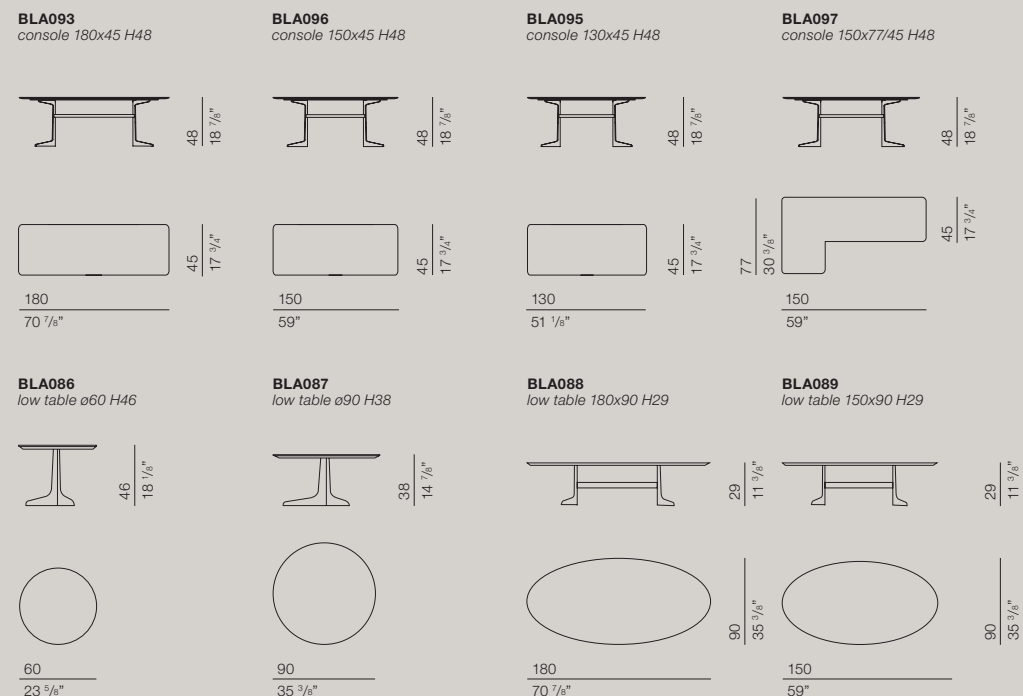

**BLA090**  
low table 180x90 H29

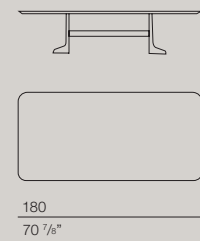

**BLA091**  
low table 150x80 H29

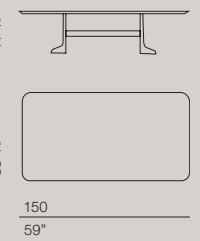

**BLA094**  
low table 130x80 H29

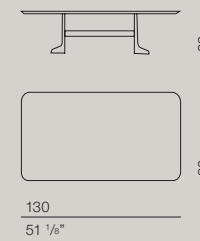

**BLA092**  
low table 90x90 H29

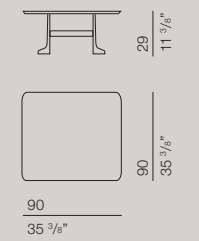

**BLUNT** DESIGN GIUSEPPE MANZONI

Serie di console e tavolini, con basamento in metallo disponibile nelle finiture Nickel nero o Bronzo Spazzolato. Il piano è disponibile in marmo Brown Emperador, Calacatta Oro, Sahara Noir, Saint Laurent, Calacatta Oro, Sahara Noir, Saint Laurent, Marron Damasco and Stardust, in a matt or glossy finish.

Console-table and coffee-tables with metal base in black chrome and sanded bronze finish. Marble top in Brown Emperador, Calacatta Oro, Sahara Noir, Saint Laurent, Marron Damasco and Stardust, in a matt or glossy finish.

Serie von Konsolen und Couchtischen, mit Metallfüße schwarz verchromt oder gebürstete Bronze. Tischplatte verfügbar aus Marmor Brown Emperador, Calacatta Oro, Sahara Noir, Saint Laurent, Marron Damasco und Stardust – glänzend oder matt.

Série de consoles et de petite tables, avec pieds en métal disponible en chrome noir ou bronze brossé. Top disponible en marbre Brown Emperador, Calacatta Oro, Sahara Noir, Saint Laurent, Marron Damasco et Stardust – brillant ou mat.

**BLU000**  
low table 45x45 H40

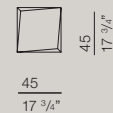

**BLU001**  
low console 40x140 H40

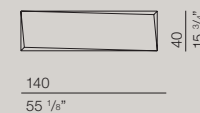

**BLU002**  
high console 40x140 H72

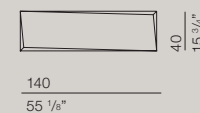

**BUTTON** DESIGN STUDIO RES

Collezione di pouff e panche dalle linee morbide, disponibili in varie forme e misure. Struttura in legno rivestita in poliuretano espanso D30. Piano arricchito da bottoni decorativi. Piedino a scomparsa in plastica nera.

Ottomans and benches of soft-shaped design in different dimensions. Wooden frame covered with D30 polyurethane foam. Top with decorative buttons. Hidden black plastic feet.

Kollektion von Hocker und Bänken mit weichen Linien, verfügbar in verschiedenen Formen und Größen. Holzrahmen verkleidet mit D30 Polyurethanschaum und durch dekorative Knöpfen wertvoll gemacht. Einklappbarer Fuß aus schwarze Kunststoff.

Collection de Poufs et bancs de design doux, disponibles dans différentes formes et tailles. Structure en bois revêtu en polyuréthane expansé D30 et enrichi par des boutons décoratifs. Pied rétractable en plastique noir.

**BOT001**  
ottoman 80 X 80

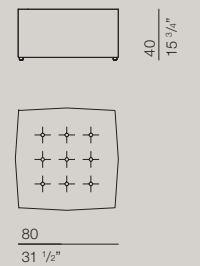

**BOT002**  
ottoman 100 X 100

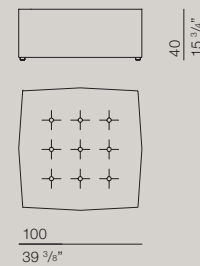

**BOT003**  
ottoman ø80



**BOT004**  
ottoman ø100

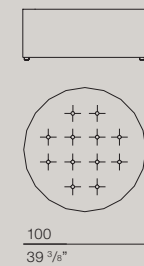

**BOT005**  
bench 140 x 50

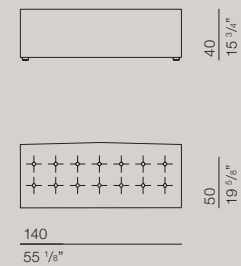

**CHIO** DESIGN GIUSEPPE MANZONI

Tavolino a forma di petalo con piedini in metallo finitura cromo nero il piano bisellato è in marmo Brown Emperador, Calacatta Oro, Sahara Noir, Saint Laurent, Marron Damasco and Stardust lucido o opaco.

Petal-shaped top with metal legs in black chrome finish. Bevelled marble top in Emperador Brown, Calacatta Oro, Sahara Noir, Saint Laurent, Marron Damasco and Stardust in a matt or glossy finish.

Couchtisch in Form eines Blütenblatt mit schwarzverchromten Metallfüße. Tischplatte mit Abschrängen aus Marmor Brown Emperador, Calacatta Oro, Sahara Noir, Saint Laurent, Marron Damasco et Stardust – glänzend oder matt.

Petit table en forme de pétale avec pieds en métal chromé noir. Le top avec biseautage est en marbre Brown Emperador, Calacatta Oro, Sahara Noir, Saint Laurent, Marron Damasco et Stardust – brillant ou mat.

**CHIO00**  
low table 70x45 H40

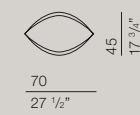

**CI LOW TABLE** DESIGN CARLOTTA MANZONI

Serie di tavolini, con basamento in metallo verniciato a liquido disponibile nelle finiture Bronzo o Nero Piombo. Il piano bisellato è disponibile in MDF laccato lucido o opaco in tutti i colori RAL, oppure in marmo Brown Emperador, Calacatta Oro, Sahara Noir, Saint Laurent, Marron Damasco and Stardust lucido o opaco.

Coffee-tables with metal base available in bronze and lead-grey finish. Bevelled top available in any RAL colour reference lacquer and in MDF lacquered or matt in all RAL colours, or in marble Brown Emperador, Calacatta Oro, Sahara Noir, Saint Laurent, Marron Damasco and Stardust marble, in a matt or glossy finish.

Serie von Couchtischen, mit Metallgestell lackiert Bronze oder Blei-schwarz. Tischplatte mit Abschrängen verfügbar entweder aus MDF glänzend oder matt lackiert auf alle RAL Farbe, oder aus Marmor Brown Emperador, Calacatta Oro, Sahara Noir, Saint Laurent, Marron Damasco und Stardust – glänzend oder matt.

Série de petite tables avec pieds en métal polis bronze ou noir plomb. Top avec biseautage disponible en MDF lacqué brillant ou mat dans toutes couleurs RAL, ou en marbre Brown Emperador, Calacatta Oro, Sahara Noir, Saint Laurent, Marron Damasco et Stardust – brillant ou mat.

**CI000**  
low table 120 x 80

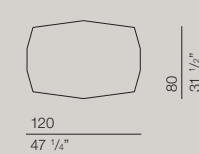

**CI001**  
low table 120 x 80

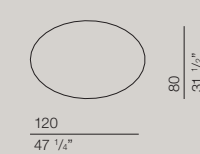

**CI003**  
low table ø80

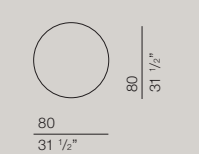

**CI004**  
low table ø50

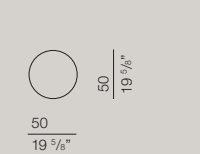

**CINQUANTA** DESIGN GIUSEPPE MANZONI

Serie di tavolini disponibili in varie forme e dimensioni, accostabili tra loro. Piedini in metallo finitura cromo nero. Il piano bisellato è disponibile in MDF laccato lucido o opaco in tutti i colori RAL, oppure in marmo Brown Emperador, Calacatta Oro, Sahara Noir, Saint Laurent, Marron Damasco and Stardust lucido o opaco.

Coffee-tables collection in different shapes and dimension to pull together. Metal legs in black chrome. Bevelled top available in any RAL colour reference lacquer and in Brown Emperador, Calacatta Oro, Sahara Noir, Saint Laurent, Marron Damasco and Stardust marble, in a matt or glossy finish.

Serie von Couchtischen in verschiedenen Formen und Größen, die miteinander verbunden werden können. Schwarzverchromte Metallfüße Tischplatte mit Abschrängen verfügbar entweder aus MDF glänzend oder matt lackiert auf alle RAL Farbe, oder aus Marmor Brown Emperador, Calacatta Oro, Sahara Noir, Saint Laurent, Marron Damasco und Stardust – glänzend oder matt.

Série de petit tables disponibles dans différentes formes et tailles, approchable l'une de l'autre. Pieds en métal chromé noir Top avec biseautage disponible en MDF lacqué brillant ou mat dans toutes couleurs RAL, ou en marbre Brown Emperador, Calacatta Oro, Sahara Noir, Saint Laurent, Marron Damasco et Stardust – brillant ou mat.

**CINQ00**  
low table 120 x 80 H30

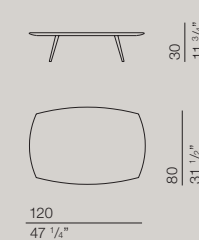

**CINQ01**  
low table 120 x 80 H35

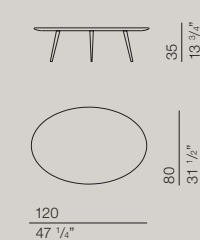

**CINQ02**  
low table ø80 H40

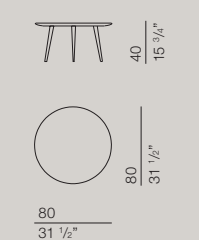

**CINQ03**  
low table 70 x 60 H45

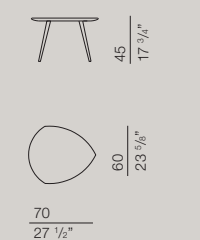

**CINQ04**  
low table ø50 H50

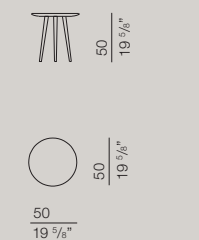

**CLESSIDRA** DESIGN GIUSEPPE MANZONI

Serie di tavolini composta da tre elementi di diverse altezze e diametro, accostabili tra loro. Disponibili in MDF laccato opaco in tutte le tinte RAL, o in MDF impiallacciato frassino tinto anilina; in entrambe le versioni, la colonna portante è in massello di frassino tinta anilina.

Coffee-tables in 3 different height and diameter to pull together. Top available in any RAL colour reference matt lacquer and in ashwood veneer, aniline stained.

Tischserie bestehend aus drei Einzeltischen unterschiedlicher Höhe und unterschiedlicher Durchmesser. Erhältlich in matt lackiertem MDF in allen RAL-Farben oder auch MDF mit Eschenfurnier. Die Tischsäule ist immer Esche massiv anilengebeizt.

Série de tables composée par trois pièces de différentes hauteurs et diamètres, approchable l'une de l'autre. Disponible en MDF laqué mat dans toutes les couleurs RAL ou MDF plaqué bois de frêne couleur aniline. Dans les deux versions la base est en bois de frêne couleur aniline.

**CLE001**  
low table ø 80



80  
31 1/2"

**CLE002**  
low table ø 65



65  
24 5/8"

**CLE003**  
low table ø 50



50  
19 3/4"

**PONTE** DESIGN GIUSEPPE MANZONI

Serie di tavolini composti da 3 elementi abbinabili ed impilabili tra loro. Disponibili nella versione con piano in Mdf laccato opaco in tutte le tinte RAL, o con piano in Mdf impiallacciato frassino e tinto anilina. Basamento in metallo cromo nero.

Coffee-tables collection made of 3 pieces to pull and to stack together. Top available in any RAL colour reference matt lacquer and in ashwood veneer, aniline stained. Metal base in black chrome.

Tischserie aus 3 Einzeltischen, die man teilweise ineinander schieben und so als Gruppe präsentieren kann. Tischplatte matt lackiert in verschiedenen RAL-Tönen oder Tischplatte Eschenfurnier weiß gebeizt mit Anilienfarben. Tischgestell schwarz verchromt.

Série de tables composée par 3 éléments combinables et empilables. Disponible dans la version MDF laqué mat dans toutes les couleurs RAL ou avec base en métal chromé noir.

**PON001**  
low table 130 x 90

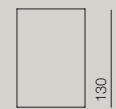

90  
35 3/8"

**PON002**  
low table 130 x 50



50  
19 3/8"

**PON003**  
low table 60 x 60



60  
23 3/8"

**SIEVE** DESIGN NOB ARCHITETTURA

Serie di tavolini circolari, dalle linee pulite ed essenziali. Declinata in tre varianti dimensionali è caratterizzata dalla tipologia a quattro gambe disposte a crociera, dove il telaio è realizzato in piatto di acciaio di grande sezione. Struttura verniciata nella variante di colore bronzo, piano in vetro temperato retro-laccato RAL7044.

Round coffee-tables collection of a simple design. 3 dimensions to match customer's requirement, 4 feet arranged in a cross order, frame with supporting steel top. Base in bronze finish, tempered glass top lacquered in RAL 7044 colour code and available in any other RAL reference on demand.

Serie von runden Beistelltischen im klaren Design mit 3 verschiedenen Größen. Der Stahlrahmen besteht aus 4 kreuzförmig-angeordneten Füßen und ist bronzefarben lackiert. Tischplatte aus vorgespanntem Glas mit RAL-7044 lackierter Rückseite.

Série de petit tables de design très essentielles. Disponibles en 3 dimensions, structure en acier, forme des pieds croisés. Structure verni en coloris bronze, top en verre recuit - laqué à l'arrière en RAL7044.

**SIV000**  
low table S ø 48



48  
18 7/8"



48  
18 7/8"

**SIV001**  
low table M ø 84



84  
33 1/8"



84  
33 1/8"

**SIV002**  
low table L ø 120



120  
47 1/4"



120  
47 1/4"

**SUMO** DESIGN GIUSEPPE MANZONI

Collezione di pouff dalle linee morbide, disponibili in varie forme e misure. Struttura in legno rivestita in poliuretano espanso D30. Basamento in legno tinto wengé.

Ottomans collection of a soft-shaped design available in different dimensions. Wooden frame covered in D30 polyurethane foam. Wooden base in wengé stain.

Hockerkollektion mit weichen Linien, verfügbar in verschiedenen Formen und Größen. Holzrahmen verkleidet mit D30 Polyurethanschaum. Holzsockel wengé gebeizt.

Collection de Poufs de design doux, disponibles dans différentes formes et tailles. Structure en bois revêtu en polyuréthane expansé D30. Basement en bois teinté wengé.

**SUMO000**  
ottoman 60 x 70



70  
27 1/2"



60  
23 3/8"

70  
27 1/2"

**SUMO001**  
ottoman ø60

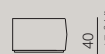

60  
23 3/8"



60  
23 3/8"

60  
23 3/8"

**SUMO002**  
ottoman ø80



80  
31 1/2"



80  
31 1/2"

80  
31 1/2"

**SUMO003**  
ottoman ø100

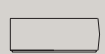

100  
39 3/8"



100  
39 3/8"

100  
39 3/8"

Struttura in legno rivestita in poliuretano espanso. Rete in metallo e doghe di faggio con regolatori di rigidità. Imbottitura in poliuretano rivestito con fodera in vellutino in fibra di nylon. Piedini o giroletto disponibile nelle finiture Wengé, Cromo nero e Bronzo spazzolato. Rivestimento in tessuto completamente sfoderabile. Rivestimento in pelle con possibili cuciture su testiera e/o giroletto. Disponibile anche nelle versioni contenitore e contenitore con doppio rialzo.

Wooden frame with polyurethane foam upholstery. Wooden slats spring. Upholstery in polyurethane covered in nylon light velvet fabric. Feet or bedframe available in wengé stain, black chrome and sanded bronze finish. Removable fabric cover. When in leather cover, optional sewing stitch on the bedframe can be required. Storage unit and double lifting storage unit on request.

Holzrahmen verkleidet mit Polyurethanschaum. Lattenrost mit Metallrahmen und verstellbaren Latten aus Buchenholz. Polsterung aus Polyurethan mit Nylonfaserüberzug. Füße und Bettgestell in wengé gebeizt, schwarzverchromt oder gebürstete Bronze. Komplett abnehmbarer Bezug. Lederbezüge bei Doppelbetten können teilende Nähte an Kopfteil und Rahmen haben. Das Bett kann einen Magazin haben aber auch einen hochstellbaren und hochklappbaren Lattenrost mit Magazin haben.

Structure en bois revêtue en polyuréthane expansé. Sommier en métal avec lattes en hêtre et régulateurs de rigidité. Rembourrage en polyuréthane revêtu de toile de fibre de nylon. Pieds et basement de la tête de lit en finissage wengé, chrome noir ou bronze brossé. Housse complètement amovible. Housse en cuir: dans la version lit matrimonial, il est possible d'avoir des coutures sur la tête et/ou tout autour le lit. Disponible aussi avec coffre et avec coffre système Komodo, ouverture totale.

Struttura in legno rivestita in poliuretano espanso. Rete in metallo e doghe di faggio con regolatori di rigidità. Imbottitura in poliuretano rivestito con fodera in vellutino in fibra di nylon. Piedini e barra di testiera disponibili nelle finiture Wengé, Cromo nero e Bronzo spazzolato. Rivestimento in tessuto completamente sfoderabile. Rivestimento in pelle con possibili cuciture su giroletto. Disponibile anche nelle versioni contenitore e contenitore con doppio rialzo.

Wooden frame padded in polyurethane foam. Wooden slats spring. Upholstery in polyurethane covered in nylon light velvet fabric. Feet and headboard socle in wengé stain, black chrome or sanded bronze finish. Removable fabric cover. When in leather cover, optional sewing stitch on the bedframe can be required. Storage unit and double lifting storage unit available.

Holzrahmen verkleidet mit Polyurethanschaum. Lattenrost mit Metallrahmen und verstellbaren Latten aus Buchenholz. Polsterung aus Polyurethan mit Nylonfaserüberzug. Füße und Kopfteil Gestell wengé gebeizt, schwarzverchromt oder gebürstete Bronze. Komplett abnehmbarer Bezug. Lederbezüge bei Doppelbetten können teilende Nähte an Kopfteil und Rahmen haben. Das Bett kann einen Magazin haben aber auch einen hochstellbaren und hochklappbaren Lattenrost mit Magazin haben.

Structure en bois revêtue en polyuréthane expansé. Sommier en métal avec lattes en hêtre et régulateurs de rigidité. Rembourrage en polyuréthane revêtu de toile de fibre de nylon. Pieds et basement de la tête de lit en finissage wengé, chrome noir ou bronze brossé. Housse complètement amovible. Housse en cuir: dans la version lit matrimonial, il est possible d'avoir des coutures sur la tête et/ou tout autour le lit. Disponible aussi avec coffre et avec coffre système Komodo, ouverture totale.

bed with under frame

**AURO000**  
fixed bed with base 160 x 200  
**AURO100**  
storage bed with base 160 x 200  
**AURO200**  
storage bed with double opening mechanism 160 x 200

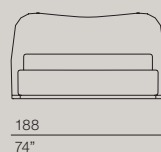
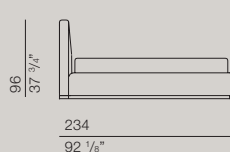

**AURO001**  
fixed bed with base 180 x 200  
**AURO101**  
storage bed with base 180 x 200  
**AURO201**  
storage bed with double opening mechanism 180 x 200

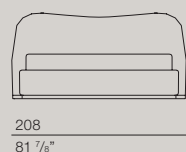

**AURO002**  
fixed bed with base 200 x 200  
**AURO102**  
storage bed with base 200 x 200  
**AURO202**  
storage bed with double opening mechanism 200 x 200

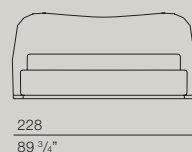

bed with 2 feet

**AURO003**  
fixed bed with base 160x200

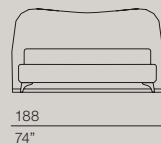
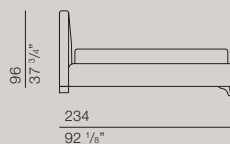

**AURO004**  
fixed bed with base 180x200

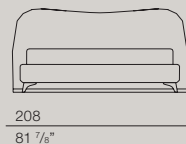

**AURO005**  
fixed bed with base 200x200

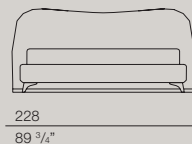

**DALT000**  
fixed bed with base 160 x 200  
**DALT010**  
storage bed with base 160 x 200  
**DALT020**  
storage bed with double opening mechanism 160 x 200

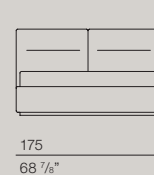
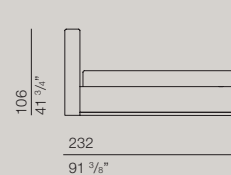

**DALT001**  
fixed bed with base 180 x 200  
**DALT011**  
storage bed with base 180 x 200  
**DALT021**  
storage bed with double opening mechanism 180 x 200

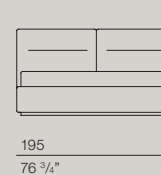

**DALT002**  
fixed bed with base 200 x 200  
**DALT012**  
storage bed with base 200 x 200  
**DALT022**  
storage bed with double opening mechanism 200 x 200

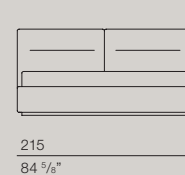

Struttura in legno rivestita in poliuretano espanso. Rete in metallo e doghe di faggio con regolatori di rigidità. Imbottitura in poliuretano rivestito con fodera in vellutino in fibra di nylon. Piedini in metallo nella finitura Manganese. Rivestimento in tessuto completamente sfoderabile. Rivestimento in pelle con possibili cuciture su giroletto. Disponibile con due altezze di testiera, 75 o 97 cm.

Wooden frame with polyurethane foam upholstery. Wooden slats spring. Upholstery in polyurethane covered in nylon light velvet fabric. Metal feet in manganese finish. Removable fabric cover. When in leather cover, optional sewing stitch on the bedframe can be required. 2 headboard H. cm 75 and cm 97 available.

Holzrahmen verkleidet mit Polyurethanschaum. Lattenrost mit Metallrahmen und verstellbaren Latten aus Buchenholz. Polsterung aus Polyurethan mit Nylonfaserüberzug. Metallfüße Mangan-finish. Komplet abnehmbarer Bezug. Lederbezüge bei Doppelbetten können teilende Nähte an Kopfteil und Rahmen haben. Verfügbar in zwei Kopfteilhöhen: cm. 75 oder cm. 97.

Structure en bois revêtue en polyuréthane expansé. Sommier en métal avec lattes en hêtre et régulateurs de rigidité. Rembourrage en polyuréthane revêtu de toile de fibre de nylon. Pieds en métal finissage manganèse. Housse complètement amovible. Housse en cuir: dans la version lit matrimonial, il est possible d'avoir des coutures sur la tête et/ou tout autour le lit. Tête de lit disponible en hauteurs cm 75 ou cm 97.

low headboard H 75

**HAR000**  
fixed bed with base 160 x 200

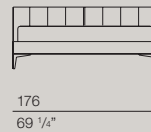
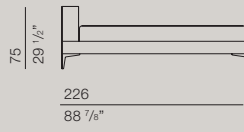

**HAR001**  
fixed bed with base 180 x 200

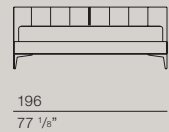

**HAR002**  
fixed bed with base 200 x 200

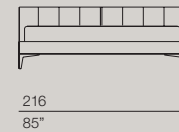

high headboard H 97

**HAR003**  
fixed bed with base 160 x 200

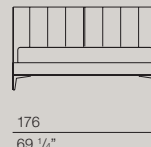
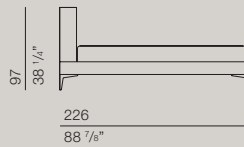

**HAR004**  
fixed bed with base 180 x 200

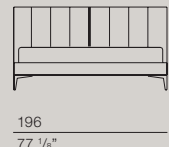

**HAR005**  
fixed bed with base 200 x 200

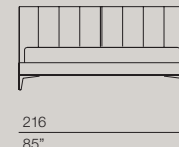

Struttura in legno rivestita in poliuretano espanso. Rete in metallo e doghe di faggio con regolatori di rigidità. Imbottitura in poliuretano rivestito con fodera in vellutino in fibra di nylon. Piedini cilindrici in legno. Rivestimento in tessuto completamente sfoderabile. Rivestimento in pelle con possibili cuciture su giroletto. Disponibile anche nelle versioni contenitore e contenitore con doppio rialzo.

Wooden frame with polyurethane foam upholstery. Wooden slats spring. Upholstery in polyurethane covered in nylon light velvet fabric. Wooden cylindrical feet, stained. Removable fabric cover. When in leather cover, optional sewing stitch on the bedframe can be required. Storage unit and double lifting storage unit available.

Holzrahmen verkleidet mit Polyurethanschaum. Lattenrost mit Metallrahmen und verstellbaren Latten aus Buchenholz. Polsterung aus Polyurethan mit Nylonfaserüberzug. Zylindrische FüÙe aus Holz. Komplet abnehmbarer Bezug. Lederbezüge bei Doppelbetten können teilende Nähte an Kopfteil und Rahmen haben. Das Bett kann einen Magazin haben aber auch einen hochstellbaren oder hochklappbaren Lattenrost mit Magazin haben.

Structure en bois revêtue en polyuréthane expansé. Sommier en métal avec lattes en hêtre et régulateurs de rigidité. Rembourrage en polyuréthane revêtu de toile de fibre de nylon. Pieds cylindriques en bois. Housse complètement amovible. Housse en cuir: dans la version lit matrimonial, il est possible d'avoir des coutures sur la tête et/ou tout autour le lit. Disponible aussi avec coffre et avec coffre système Komodo, ouverture totale.

fixed bed

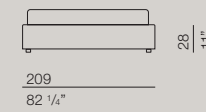

**LULU00**  
fixed bed with base 100 x 200

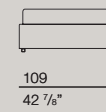

**LULU01**  
fixed bed with base 120 x 200

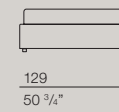

**LULU02**  
fixed bed with base 140 x 200

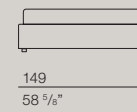

**LULU03**  
fixed bed with base 160 x 200

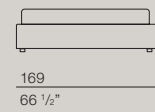

storage bed

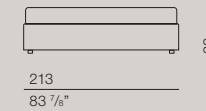

**LULU10**  
storage bed with base 100 x 200  
**LULU20**  
storage bed with double opening mechanism 100 x 200

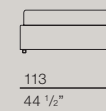

**LULU11**  
storage bed with base 120 x 200  
**LULU21**  
storage bed with double opening mechanism 120 x 200

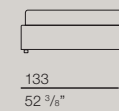

**LULU12**  
storage bed with base 140 x 200  
**LULU22**  
storage bed with double opening mechanism 140 x 200

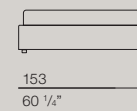

**LULU13**  
storage bed with base 160 x 200  
**LULU23**  
storage bed with double opening mechanism 160 x 200

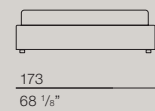

**LULU14**  
storage bed with base 180 x 200  
**LULU24**  
storage bed with double opening mechanism 180 x 200

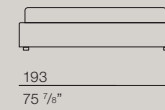

**LULU15**  
storage bed with base 200 x 200  
**LULU25**  
storage bed with double opening mechanism 200 x 200

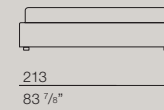

Struttura in legno rivestita in poliuretano espanso. Rete in metallo e doghe di faggio con regolatori di rigidità. Imbottitura in poliuretano rivestito con fodera in vellutino in fibra di nylon. Piedini in metallo nella finitura Manganese. Rivestimento in tessuto completamente sfoderabile. Rivestimento in pelle con possibili cuciture su giroletto. Disponibile nella finitura con testiera liscia e con testiera cordonata.

Wooden frame with polyurethane foam upholstery. Wooden slats spring. Upholstery in polyurethane covered in nylon light velvet fabric. Metal feet in manganese finish. Removable fabric cover. When in leather cover, optional sewing stitch on the bedframe can be required. Headboard available with piping on demand.

Holzrahmen verkleidet mit Polyurethanschaum. Lattenrost mit Metallrahmen und verstellbaren Latten aus Buchenholz. Polsterung aus Polyurethan mit Nylonfaserüberzug. Metallfüße Mangan-finish. Komplet abnehmbarer Bezug. Lederbezüge bei Doppelbetten können teilende Nähte an Kopfteil und Rahmen haben. Der Kopfteil kann einfach oder mit Schnur verarbeitet werden.

Structure en bois revêtue en polyuréthane expansé. Sommier en métal avec lattes en hêtre et régulateurs de rigidité. Rembourrage en polyuréthane revêtu de toile de fibre de nylon. Pieds en métal finissage Manganèse. Housse complètement amovible. Housse en cuir: dans la version lit matrimonial, il est possible d'avoir des coutures sur la tête et/ou tout autour le lit. Tête de lit disponible soit lisse que avec couture-cordon.

Struttura in legno rivestita in poliuretano espanso. Rete in metallo e doghe di faggio con regolatori di rigidità. Imbottitura in poliuretano rivestito con fodera in vellutino in fibra di nylon. Piedini cilindrici in plastica nera. Rivestimento in tessuto completamente sfoderabile. Rivestimento in pelle con possibili cuciture su testiera e/o giroletto. Disponibile anche nelle versioni contenitore e contenitore con doppio rialzo.

Wooden frame with polyurethane foam upholstery. Wooden slats spring. Upholstery in polyurethane covered in nylon light velvet fabric. Black plastic cylindrical feet. Removable fabric cover. When in leather cover, optional sewing stitch on headboard / bedframe can be required. Storage unit and double lifting storage unit on request.

Holzrahmen verkleidet mit Polyurethanschaum. Selbsttragender Lattenrost mit Metallrahmen und verstellbaren Latten aus Buchenholz. Polsterung aus Polyurethan mit Nylonfaserüberzug. Zylindrische Füße aus schwarze Kunststoff. Komplet abnehmbarer Bezug. Lederbezüge bei Doppelbetten können teilende Nähte an Kopfteil und Rahmen haben. Das Bett kann einen Magazin haben aber auch einen hochstellbaren und hochklappbaren Lattenrost mit Magazin haben.

Structure en bois revêtue en polyuréthane expansé. Sommier en métal avec lattes en hêtre et régulateurs de rigidité. Rembourrage en polyuréthane revêtu de toile de fibre de nylon. Pieds cylindriques en plastique noir. Housse complètement amovible. Housse en cuir: dans la version lit matrimonial, il est possible d'avoir des coutures sur la tête et/ou tout autour le lit. Disponible aussi avec coffre et avec coffre système Komodo, ouverture totale.

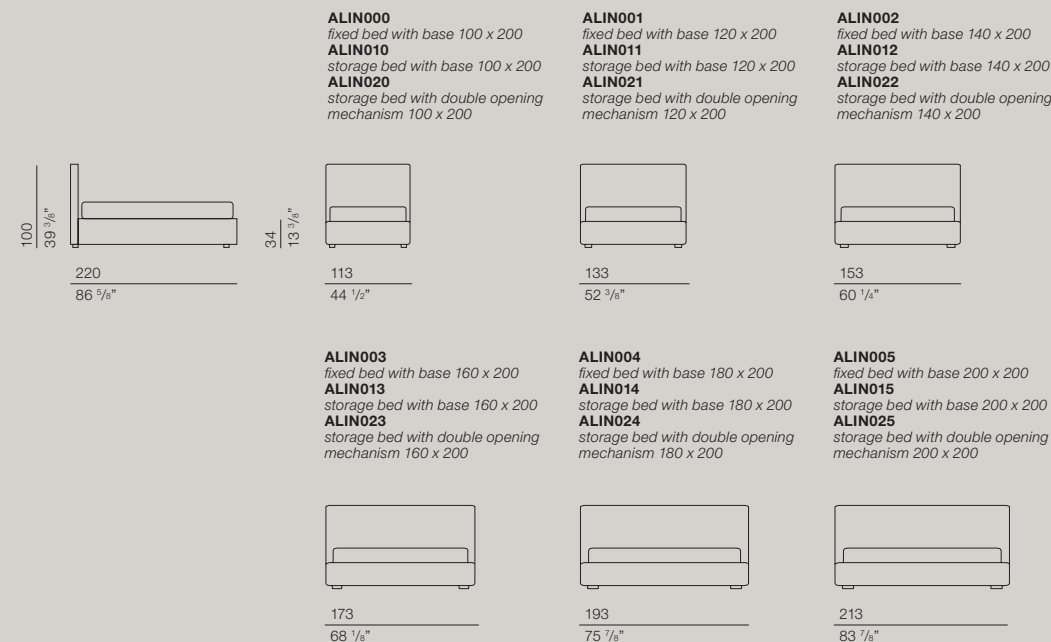
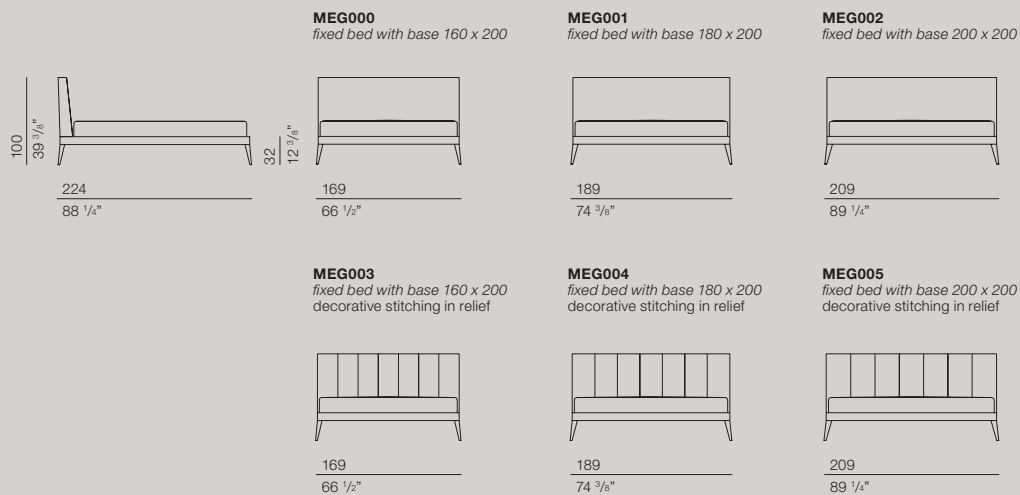

Struttura in legno rivestita in poliuretano espanso. Rete in metallo e doghe di faggio con regolatori di rigidità. Imbottitura in poliuretano rivestito con fodera in vellutino in fibra di nylon. Piedini o giroletto disponibili nelle finiture Wengé, Cromo nero e Bronzo spazzolato. Rivestimento in tessuto completamente sfoderabile. Rivestimento in pelle con possibili cuciture su testiera e/o giroletto. Disponibile anche nelle versioni contenitore e contenitore con doppio rialzo. Disponibile nella finitura con testiera liscia, con taglio o con bottoni.

Wooden frame with polyurethane foam upholstery. Wooden slats spring. Upholstery in polyurethane covered in nylon light velvet fabric. Feet or bedframe available in wengé stain, black chrome and in sanded bronze finish. Removable fabric cover. When in leather cover, optional sewing stitch on the bedframe can be required. Storage unit and double lifting storage unit on request. Headboard available with plain upholstery, with central sewing or buttons on customer's specification.

Holzrahmen verkleidet mit Polyurethanschaum. Lattenrost mit Metallrahmen und verstellbaren Latten aus Buchenholz. Polsterung aus Polyurethan mit Nylonfaserüberzug. Füße oder bettgestell in wengé gebeizt, schwarzverchromt oder gebürstete Bronze. Komplett abnehmbarer Bezug. Lederbezüge bei Doppelbetten können teilende Nähte an Kopfteil und Rahmen haben Das Bett kann einen Magazin haben aber auch einen hochstellbaren und hochklappbaren Lattenrost mit Magazin haben. Der Kopfteil kann einfach, mit Zerlegen-Naht oder mit gesteppten Knöpfen verarbeitet werden.

Structure en bois revêtue en polyuréthane expansé. Sommier en métal avec lattes en hêtre et régulateurs de rigidité. Rembourrage en polyuréthane revêtu de toile de fibre de nylon. Pieds et basement de la tête de lit en finissage wengé, chrome noir ou bronze brossé. Housse complètement amovible. Housse en cuir: dans la version lit matrimonial, il est possible d'avoir des coutures sur la tête et/ou tout autour le lit. Disponible aussi avec coffre et avec coffre système Komodo, ouverture totale. Tête de lit disponible soit lisse que avec couture-découpe ou avec boutons.

headboard with plain upholstery

**SOPH000**  
fixed bed with base 160 x 200  
**SOPH100**  
storage bed with base 160 x 200  
**SOPH200**  
storage bed with double opening mechanism 160 x 200

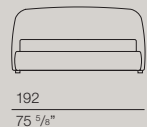

**SOPH001**  
fixed bed with base 180 x 200  
**SOPH101**  
storage bed with base 180 x 200  
**SOPH201**  
storage bed with double opening mechanism 180 x 200

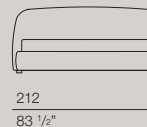

**SOPH002**  
fixed bed with base 200 x 200  
**SOPH102**  
storage bed with base 200 x 200  
**SOPH202**  
storage bed with double opening mechanism 200 x 200

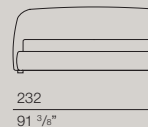

headboard with plain upholstery

**SOPH003**  
fixed bed with base 160 x 200  
**SOPH103**  
storage bed with base 160 x 200  
**SOPH203**  
storage bed with double opening mechanism 160 x 200

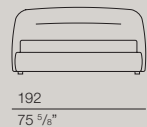

**SOPH004**  
fixed bed with base 180 x 200  
**SOPH104**  
storage bed with base 180 x 200  
**SOPH204**  
storage bed with double opening mechanism 180 x 200

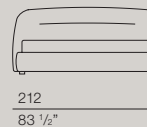

**SOPH005**  
fixed bed with base 200 x 200  
**SOPH105**  
storage bed with base 200 x 200  
**SOPH205**  
storage bed with double opening mechanism 200 x 200

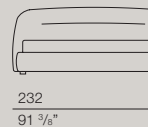

headboard with buttons

**SOPH006**  
fixed bed with base 160 x 200  
**SOPH106**  
storage bed with base 160 x 200  
**SOPH206**  
storage bed with double opening mechanism 160 x 200

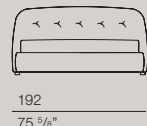

**SOPH007**  
fixed bed with base 180 x 200  
**SOPH107**  
storage bed with base 180 x 200  
**SOPH207**  
storage bed with double opening mechanism 180 x 200

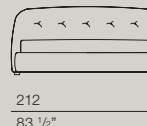

**SOPH008**  
fixed bed with base 200 x 200  
**SOPH108**  
storage bed with base 200 x 200  
**SOPH208**  
storage bed with double opening mechanism 200 x 200



Struttura in legno rivestita in poliuretano espanso. Rete in metallo e doghe di faggio con regolatori di rigidità. Imbottitura in poliuretano rivestito con fodera in vellutino in fibra di nylon. Piedini cilindrici in plastica nera. Rivestimento in tessuto completamente sfoderabile. Rivestimento in pelle con possibili cuciture su testiera e/o giroletto. Disponibile anche nelle versioni contenitore e contenitore con doppio rialzo.

Wooden frame with polyurethane foam upholstery. Wooden slats spring. Upholstery in polyurethane covered in nylon light velvet fabric. Black plastic cylindrical feet. Removable fabric cover. When in leather cover, optional sewing stitch on headboard / bedframe can be required. Storage unit and double lifting storage unit on request.

Holzrahmen verkleidet mit Polyurethanschaum. Selbsttragender Lattenrost mit Metallrahmen und verstellbaren Latten aus Buchenholz. Polsterung aus Polyurethan mit Nylonfaserüberzug. Zylindrische Füße aus schwarze Kunststoff. Komplett abnehmbarer Bezug. Lederbezüge bei Doppelbetten können teilende Nähte an Kopfteil und Rahmen haben Das Bett kann einen Magazin haben aber auch einen hochstellbaren und hochklappbaren Lattenrost mit Magazin haben.

Structure en bois revêtue en polyuréthane expansé. Sommier en métal avec lattes en hêtre et régulateurs de rigidité. Rembourrage en polyuréthane revêtu de toile de fibre de nylon. Pieds cylindriques en plastique noir. Housse complètement amovible. Housse en cuir: dans la version lit matrimonial, il est possible d'avoir des coutures sur la tête et/ou tout autour le lit. Disponible aussi avec coffre et avec coffre système Komodo, ouverture totale.

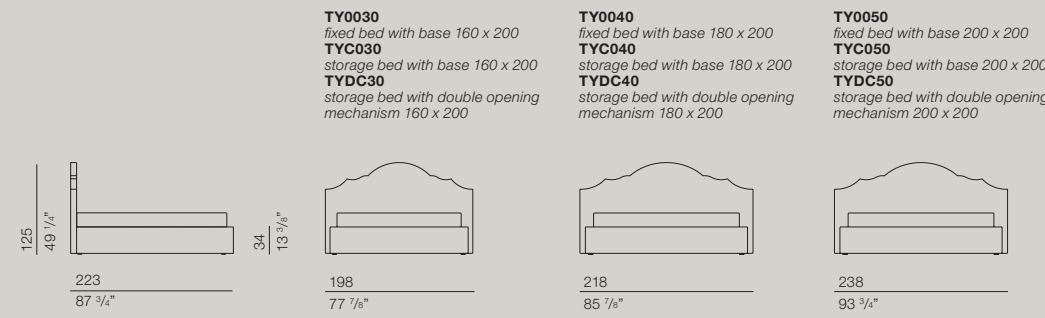

Struttura in legno rivestita in poliuretano espanso. Rete in metallo e doghe di faggio con regolatori di rigidità. Imbottitura in poliuretano rivestito con fodera in vellutino in fibra di nylon. Piedini e barra di testiera disponibili nelle finiture Wengé, Cromo nero e Bronzo spazzolato. Rivestimento in tessuto completamente sfoderabile. Rivestimento in pelle con possibili cuciture su giroletto.

Wooden frame with polyurethane foam upholstery. Wooden slats spring. Upholstery in polyurethane covered in nylon light velvet fabric. Feet and headboard socle available in wengé stain, black chrome and in sanded bronze finish. Removable fabric cover. When in leather cover, optional sewing stitch on bedframe can be required.

Holzrahmen verkleidet mit Polyurethanschaum. Selbsttragender Lattenrost mit Metallrahmen und verstellbaren Latten aus Buchenholz. Polsterung aus Polyurethan mit Nylonfaserüberzug. Füße und Kopfteil Gestell wengé gebeizt, schwarzverchromt oder gebürstete Bronze. Komplett abnehmbarer Bezug. Lederbezüge bei Doppelbetten können teilende Nähte an Kopfteil und Rahmen haben.

Structure en bois revêtue en polyuréthane expansé. Sommier en métal avec lattes en hêtre et régulateurs de rigidité. Rembourrage en polyuréthane revêtu de toile de fibre de nylon. Pieds et basement de la tête de lit en finissage wengé, chrome noir ou bronze brossé. Housse complètement amovible. Housse en cuir: dans la version lit matrimonial, il est possible d'avoir des coutures sur la tête et/ou tout autour le lit.

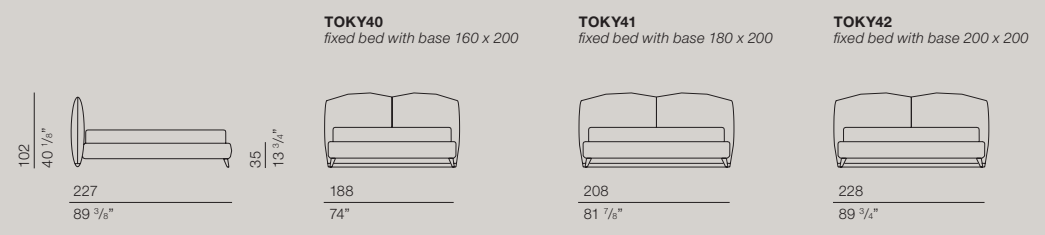



Struttura in legno rivestita in poliuretano espanso. Rete in metallo e doghe di faggio con regolatori di rigidità. Imbottitura in poliuretano rivestito con fodera in vellutino in fibra di nylon. Piedini disponibili nelle finiture Wengé, Cromo nero e Bronzo spazzolato. Rivestimento non sfoderabile. Rivestimento in pelle con possibili cuciture su testiera e/o giroletto. Disponibile anche nelle versioni contenitore e contenitore con doppio rialzo. Testiera lavorata a mano capitonné.

Wooden frame with polyurethane foam upholstery. Wooden slats spring. Upholstery in polyurethane covered in nylon light velvet fabric. Feet available in wengé stain, black chrome and in sanded bronze finish. UNremovable fabric cover. When in leather cover, optional sewing stitch on bedframe can be required. Storage unit and double lifting storage unit on request. Hand-padded headboard in capitonné.

Holzrahmen verkleidet mit Polyurethanschaum. Lattenrost mit Metallrahmen und verstellbaren Latten aus Buchenholz. Polsterung aus Polyurethan mit Nylonfaserüberzug. Füße wengé gebeizt, schwarzverchromt oder gebürstete Bronze. Komplett abnehmbarer Bezug. Lederbezüge bei Doppelbetten können teilende Nähte an Kopfteil und Rahmen haben Das Bett kann einen Magazin haben aber auch einen hochstellbaren und hochklappbaren Lattenrost mit Magazin haben. Der Kopfteil kann einfach, mit Zerlegen-Naht oder mit gesteppten Knöpfen verarbeitet werden.

Structure en bois revêtue en polyuréthane expansé. Sommier en métal avec lattes en hêtre et régulateurs de rigidité. Rembourrage en polyuréthane revêtu de toile de fibre de nylon. Pieds et basement de la tête de lit en finissage wengé, chrome noir ou bronze brossé. Disponible aussi avec coffre et avec coffre système Komodo, ouverture totale. Tête de lit façonné à la main avec décoration capitonné.

**VIOL000**  
fixed bed with base 160 x 200  
**VIOL003**  
storage bed with base 160 x 200  
**VIOL006**  
storage bed with double opening mechanism 160 x 200

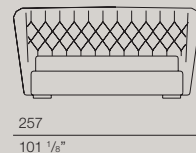
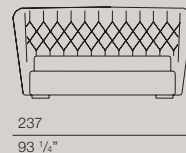
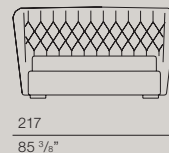
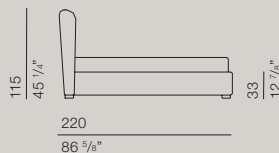

**VIOL001**  
fixed bed with base 180 x 200  
**VIOL004**  
storage bed with base 180 x 200  
**VIOL007**  
storage bed with double opening mechanism 180 x 200

**VIOL002**  
fixed bed with base 200 x 200  
**VIOL005**  
storage bed with base 200 x 200  
**VIOL008**  
storage bed with double opening mechanism 200 x 200

Serie di comodini, console e madie caratterizzati da maniglie e basamento in metallo disponibile nelle finiture Cromo nero o Bronzo Spazzolato. Struttura in MDF disponibile nelle finiture impiallacciato noce canaletto o laccato RAL lucido o opaco.

Night-tables, console-tables and cabinets with metal handle and base of design available in black Chrome and sanded Bronze finish. MDF frame in canaletto walnut veneer or in glossy / matt lacquer in any RAL colour tone.

Serie von Nacht-Tischen, Konsole-Tischen und Schränken mit Griffen und Untergestell aus schwarzverchromtem oder bronzegebürstetem Metall. MDF Gestell, Canaletto Nussbaum furniert oder matt/glänzend lackiert in jedem RAL Farbton.

Série de tables de nuit, consoles et armoires avec poignées et socle en métal disponible en chrome noir ou bronze brossé. Structure en MDF disponibles en Noyer canaletto plaqué ou laqué dans toutes colorations RAL soit mat que brillant.

**PFOF000**  
night table with one drawer

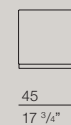
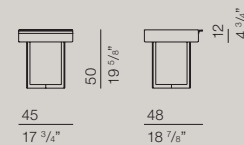

**PFOF001**  
night table with two drawers

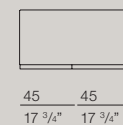
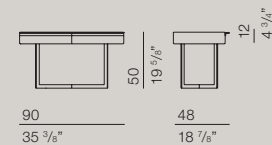

**PFOF002**  
round night table with one drawer

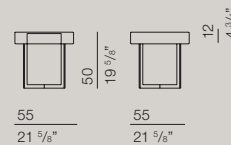

**PFOF003**  
night table with three drawers

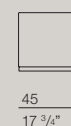
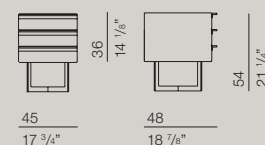

**PFOF004**  
night table with six drawers

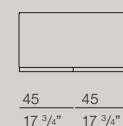
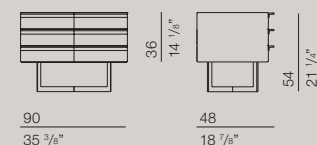

**PFOF005**  
low console

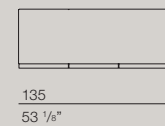
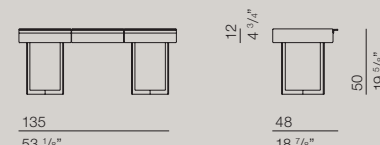

**PFOF006**  
high console

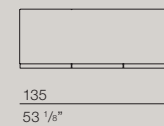
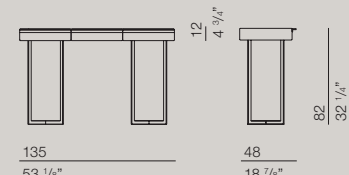

ad—  
byung soo zocchi

graphic design—  
blackspace

photos—  
nicola zocchi

stylist—  
simona cardinetti

thanks to—  
Ladosa Atelier  
Kose  
Book Import  
Molteni Home  
Nolo 150

extra photos—  
p. 21 Debby Hudson  
p. 137 Tina Admin  
p. 171 Alexander Stein  
p. 187 Kari Shea  
p. 197 Debby Hudson  
p. 241 Annie Spratt  
p. 299 Yoann Siloine

printed—  
in italy  
Nava Milano  
First edition 04.2019

# 博德玛

bodema srl—  
via padova 12  
20823 camnago di lentate sul seveso (mb)  
italy  
tel +39 0362 557255 / 60  
fax +39 0362 557271

showroom  
via g. perlasca 2  
20821 meda (mb)  
italy  
tel. +39 0362 557255 / 60

www.bodema.it  
info@bodema.it

