

TABLES AND CHAIRS

FLAI

TABLES AND CHAIRS

FLAI



PLINIO

design stch flai

04 - 09

HECTOR

design andrea lucatello

58 - 65



JONATHAN

design stch flai

10 - 17

DOMITILLA

design andrea lucatello

66 - 71



DUCCIO

design stch flai

18 - 25

KISHA

design andrea lucatello

72 - 75



MILO

design stch flai

26 - 31

CARTISIA

design andrea lucatello

76 - 81



ELVEZIO

design stch flai

32 - 37

DIOMIRA

design andrea lucatello

82 - 85



ETHAN

design studio thesia

38 - 43

NOUVELLE VOGUE

design dm design

86 - 89



CHAD

design stch flai

44 - 49

EMI-EMIMAX

design andrea lucatello

90 - 93



YURI

design andrea lucatello

50 - 57

PETRA

design dm design

96 - 99



ISIDE CHIEF

design dm design

100 - 103

SLEDGE

design andrea lucatello

114 - 115



ISIDE

design dm design

100 - 103

FRIDA

design stch flai

118 - 119



BETTA

design stch flai

104 - 107

FRIDA MAX

design stch flai

120 - 121



DOWNY

design stefano cavazzana

108 - 109

FRIDA STOOL

design stch flai

122 - 123



DOWNY WOOD

design stefano cavazzana

108 - 109

ELOISA

design stch flai

124 - 125



MAGDA

design stch flai

110 - 111

VELIA

design archirivolto

126 - 129



MAILA

design stch flai

112 - 113

MATERIALI

material

130 - 147



SLEDGE MAXI

design andrea lucatello

114 - 115

ABACO TECNICO

abacus technical

148 - 163

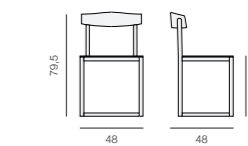







cm 115 (165) x 80 h 76
cm 140 (190 / 240) x 80 h 76
cm 140 (190 / 240) x 90 h 76
cm 160 (210 / 260) x 90 h 76
cm 180 (230 / 280) x 90 h 76

doppia allunga disponibile solo per dimensione maggiore di cm 120
double extension available only for a dimension of more than 120 cm

allunghe alloggiare nel contenitore
extensions inserted in the box



tavolo / table
JONATHAN
design stch flai



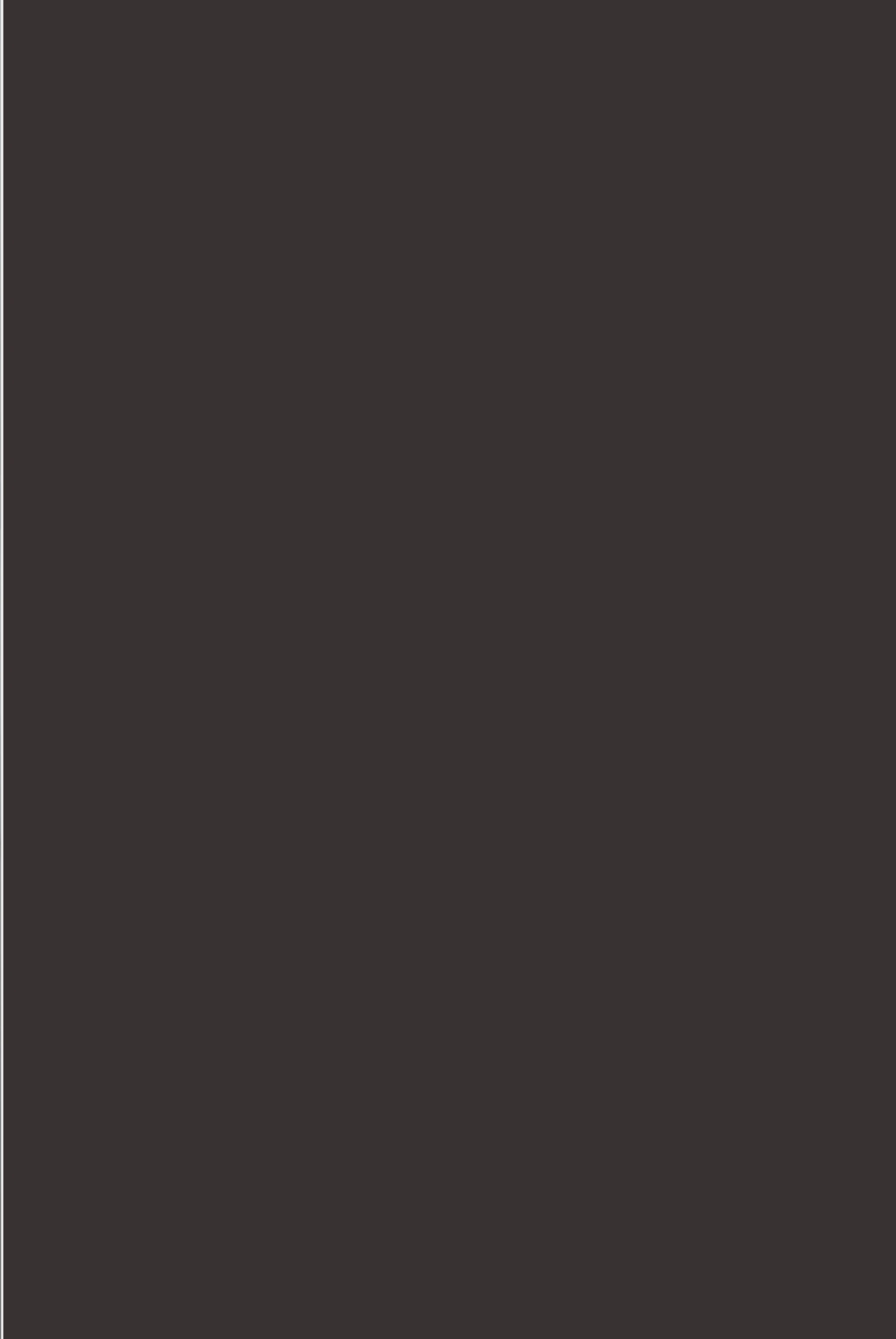



cm 115 (165) x 80 h 77
cm 140 (190) x 80 h 77
cm 140 (200) x 90 h 77
cm 160 (220) x 90 h 77
cm 180 (240) x 90 h 77

per larghezza cm 80, allunga disponibile da cm 50
with a width of 80 cm, stretch is 50 cm

allunga alloggiata nel contenitore
extensions inserted in the box



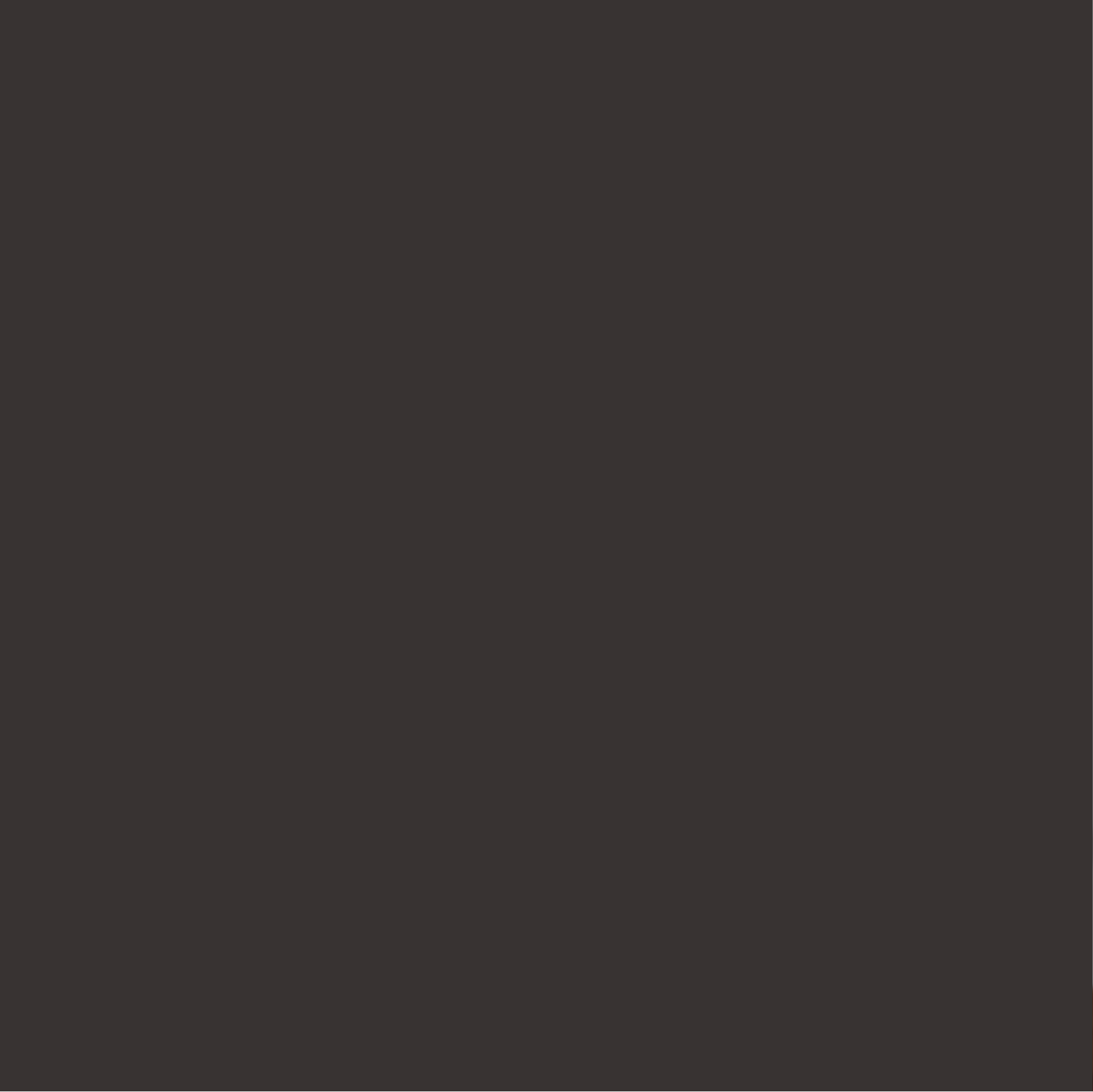





cm 160 (210 / 260) x 90 h 77
cm 180 (230 / 280) x 90 h 77
cm 210 (260 / 310) x 100 h 77
allunghie alloggiare nel contenitore
extensions inserted in the box









cm 131 (181) x 80 h 76
cm 156 (206) x 80 h 76
cm 156 (206 / 256) x 90 h 76
cm 176 (210 / 260) x 90 h 76

doppia allunga disponibile solo per dimensione maggiore di cm 145
double extension available only for a dimension of more than 145 cm

allunghe alloggiare nel contenitore
extensions inserted in the box







cm 115 (165) x 80 h 76
cm 140 (190) x 80 h 76
cm 140 (190) x 90 h 76
cm 160 (210 / 260) x 90 h 76
cm 180 (230 / 280) x 90 h 76

doppia allunga disponibile solo per dimensione maggiore di cm 145
double extension available only for a dimension of more than 145 cm

allunghe alloggiare nel contenitore
extensions inserted in the box















cm 115 (165) x 80 h 77
cm 140 (190 / 240) x 80 h 77
cm 140 (190 / 240) x 90 h 77
cm 160 (210 / 260) x 90 h 77
cm 180 (230 / 280) x 90 h 77

doppia allunga disponibile solo per dimensione maggiore di cm 120
double extension available only for a dimension of more than 120 cm

allunghie alloggiare nel contenitore
extensions inserted in the box



tavolo / table
YURI
design andrea lucatello



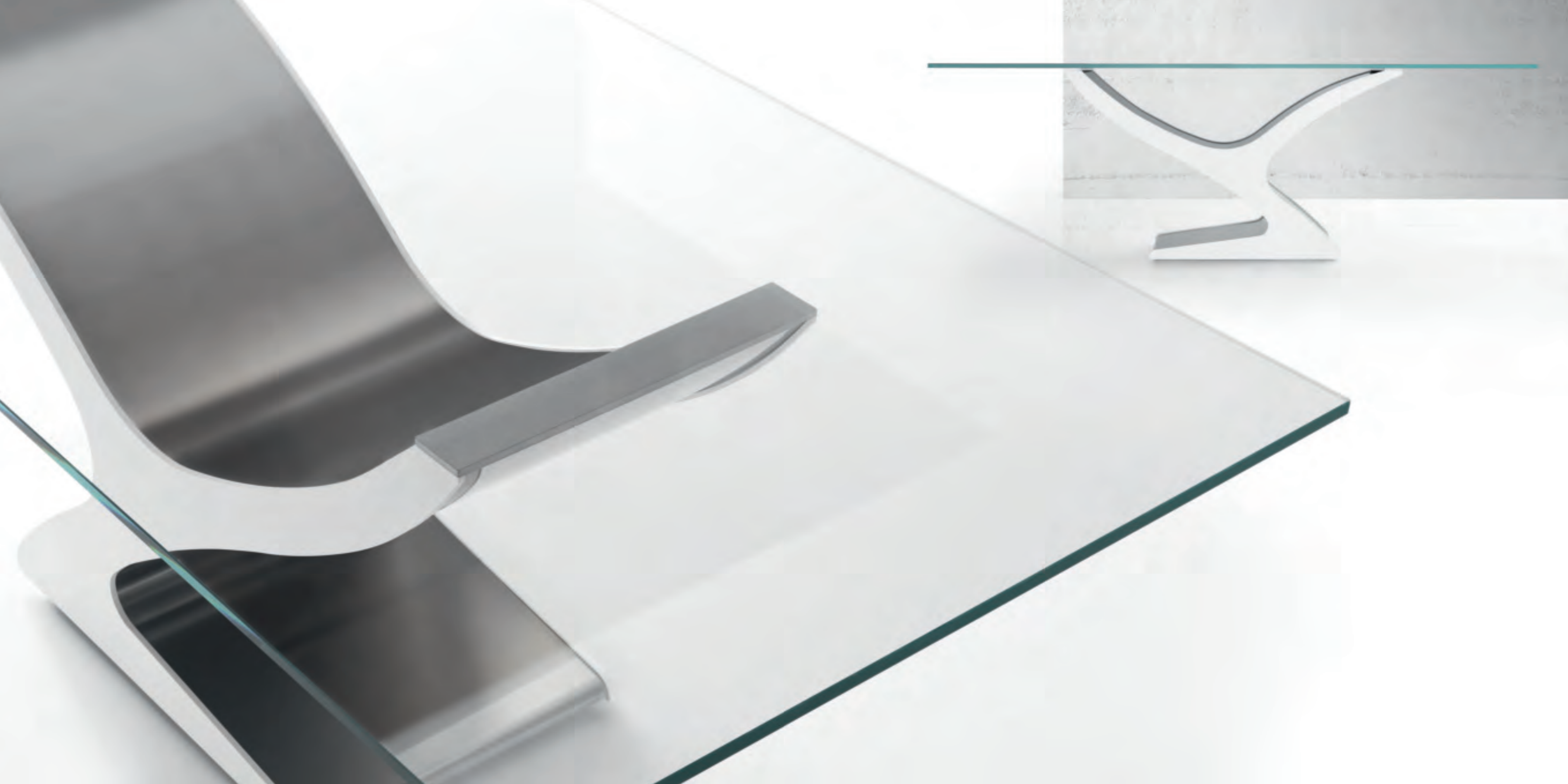

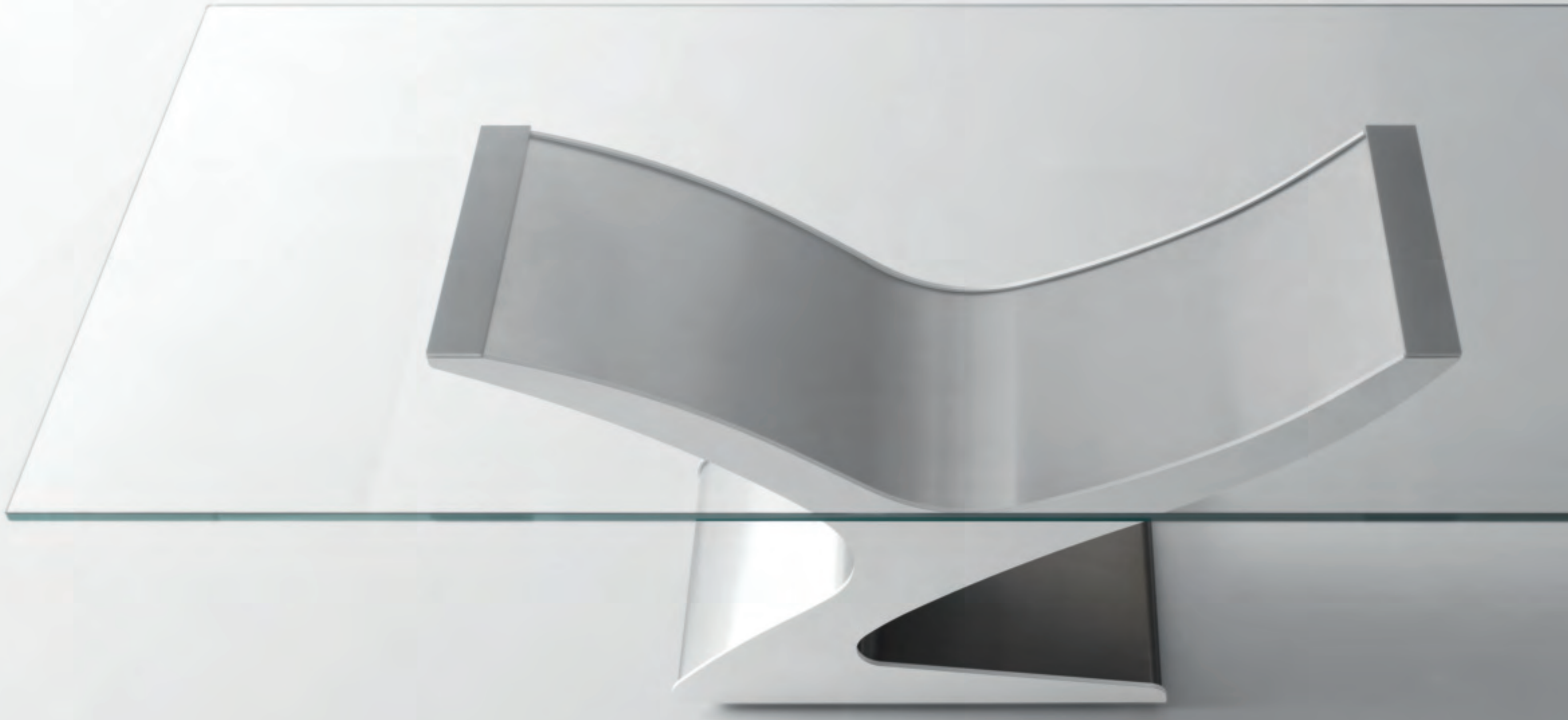





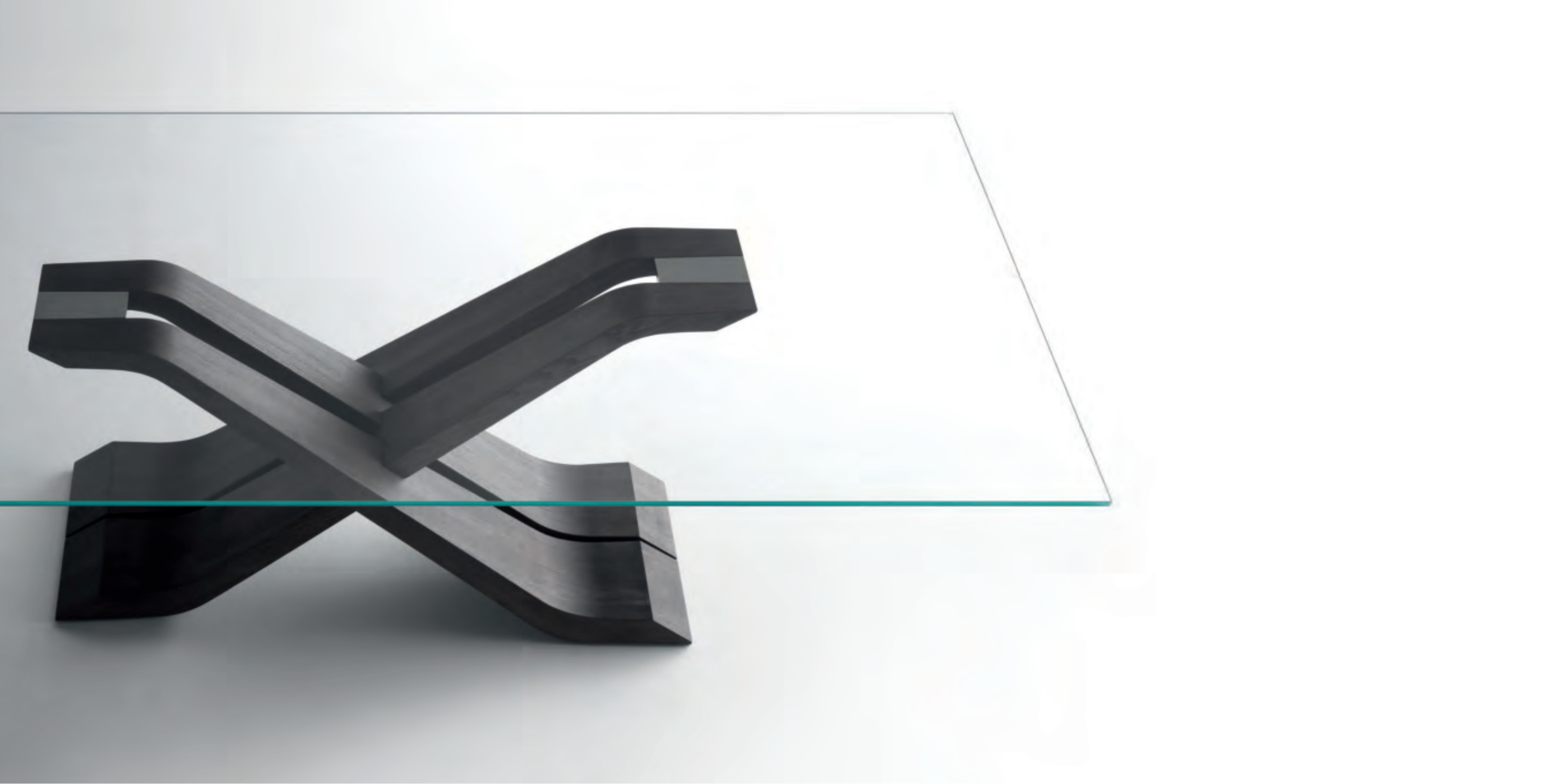





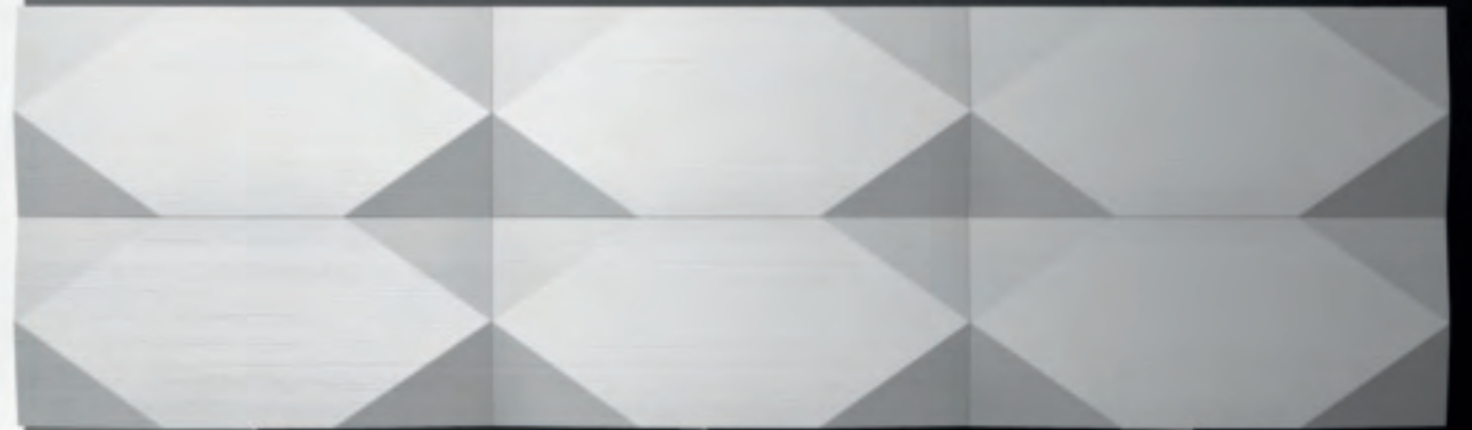

17630.C

17630.B

17630.A

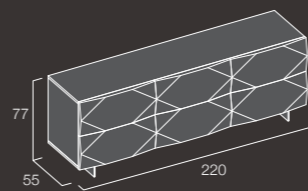
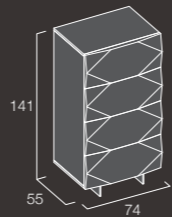
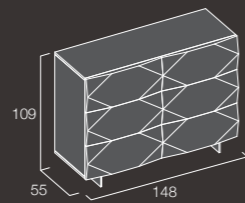









tavolo / table
CARTISIA
design andrea lucatello







madia / cupboard
DIOMIRA
design andrea lucatello





poltrona / armchair
NOUVELLE VAGUE
design dm design

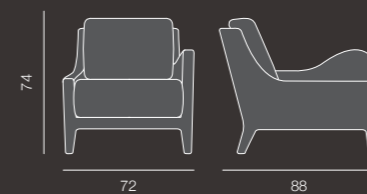





libreria / bookcase
EMIMAX
 design andrea lucatello

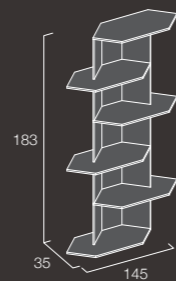

libreria / bookcase
EMI
 design andrea lucatello

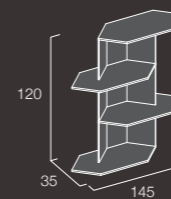





YES
YOU

$20 \times 30 = 600$
 $5 = 5$
 75
 2
 $20 - 5 = 15$
 $99 + 100 = 199$
 187
 $2 \times 20 = 40$
 $10 \times 10 = 100$



sedia / chair
PETRA
design dm design

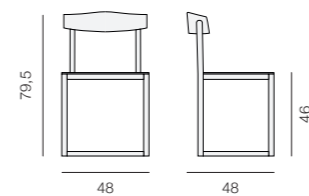





sedia / chair
ISIDE
design dm

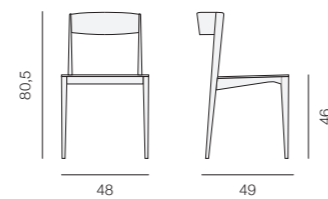

sedia con braccioli / chair with armrests
ISIDE CHIEF
design dm design

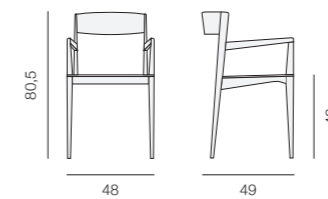





sedia / chair
BETTA
design stch flai

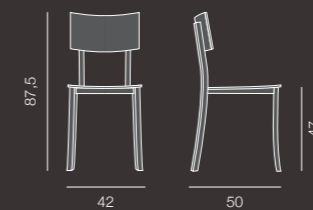





108

sedia / chair
DOWNY
design stefano cavazzana

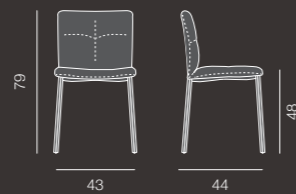

109

sedia / chair
DOWNY WOOD
design stefano cavazzana

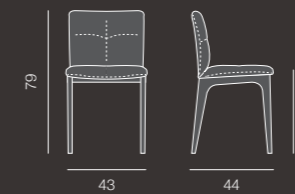



sedia / chair
MAGDA
design stch flai

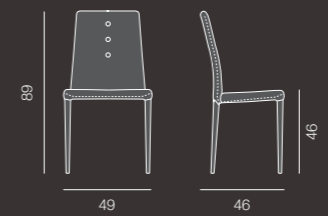



sedia / chair
MAILA
design stch flai

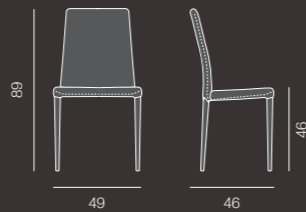



sedia / chair
SLEDGE MAXI
design andrea lucatello

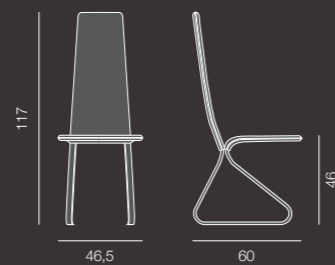

sedia / chair
SLEDGE
design andrea lucatello

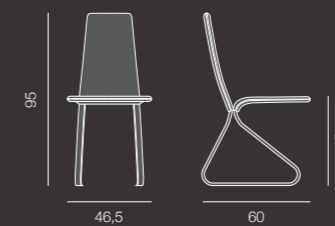





sedia / chair
FRIDA
design stch flai

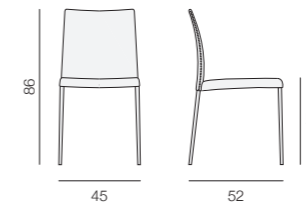



sedia / chair
FRIDA MAX
design stch flai

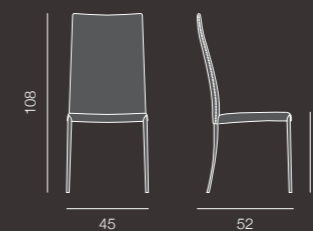



sgabello / stool
FRIDA STOOL
design stch flai

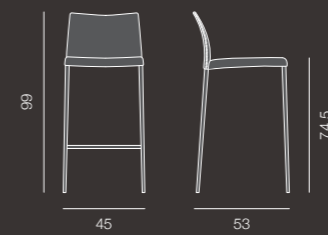



sedia / chair
ELOISA
design stch flai

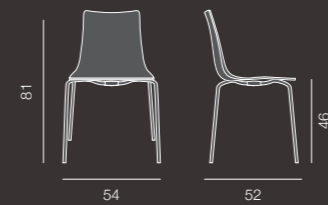



sedia / chair
VELIA
design archirivolto





MATERIALI

ABACUS TECHNICAL
ÁBACO TÉCNICA
ABAKUS TECHNISCHE

LEGNI
WOOD / MADERA / HOLZ



frassino naturale sbiancato / natural oak / natural blanco de ceniza / natural esche weiß FR



frassino tinto tabacco / tobacco oak / tabaco cenizas / Tabak Eiche FT



frassino tinto moro / wengé oak / wengé ceniza / Wenge esche RM

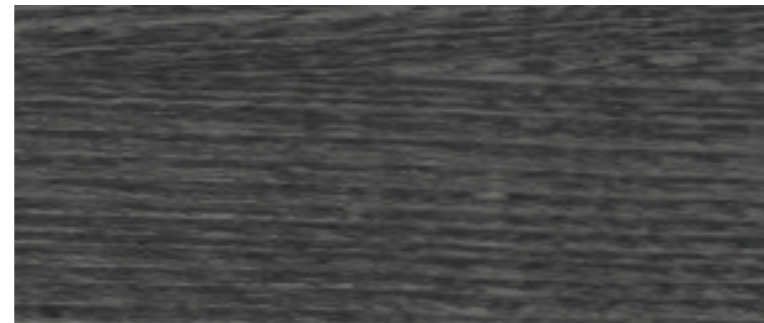

frassino tinto grigio / gray oak / gris ceniza / grau esche FG

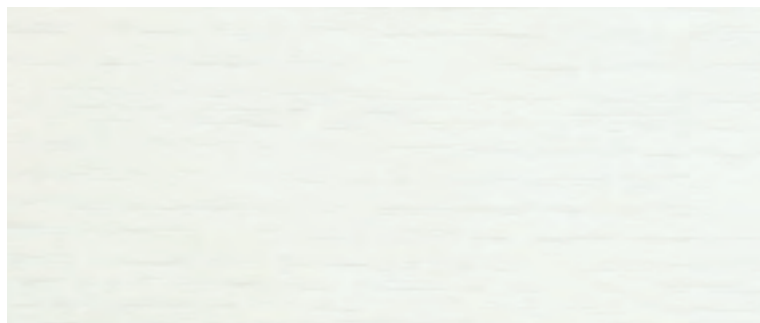

frassino bianco / white oak / blanco ceniza / Weiß esche WH



frassino grigio polvere / dusty oak / gris polvoriento ceniza / staubgrau esche GP

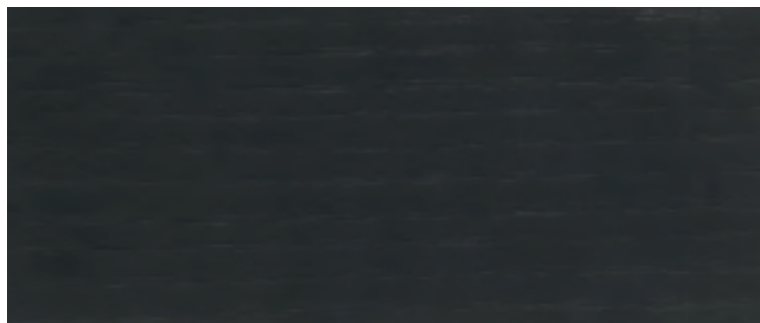

frassino nero / black oak / negro ceniza / schwarz esche NE

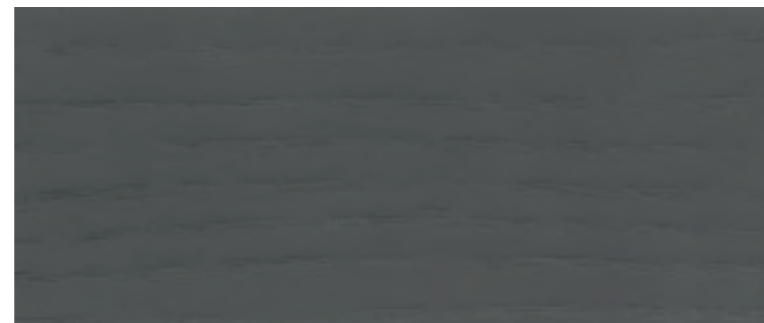

frassino grigio grafite / graphite oak / grafito ceniza / Graphit esche GS

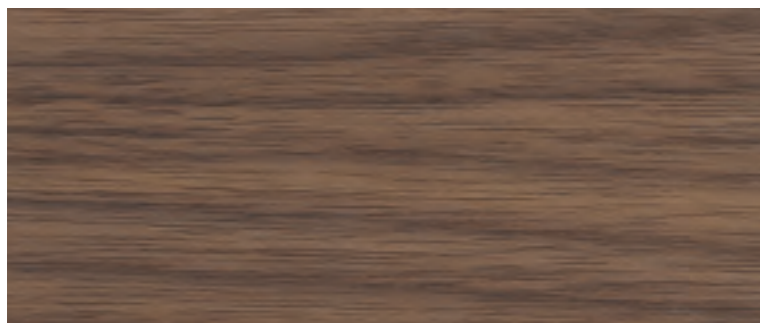

noce canaletto / canaletto walnut / canaletto nuez / canaletto Nussbaum NK

LAMINATI
LAMINATE / LAMINADO / LAMINAT

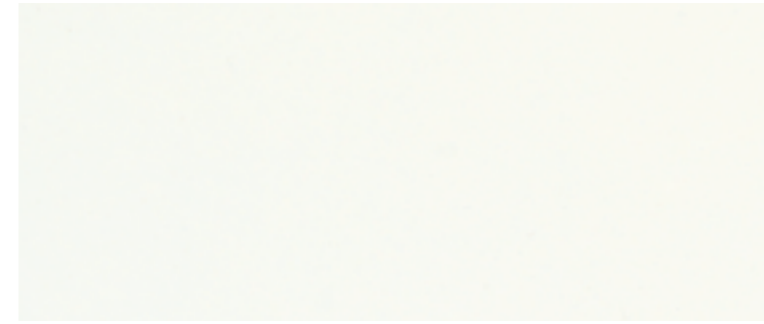

bianco / white / blanco / Weiß WH



grigio polvere / dusty grey / gris polvoriento / staubgrau GP

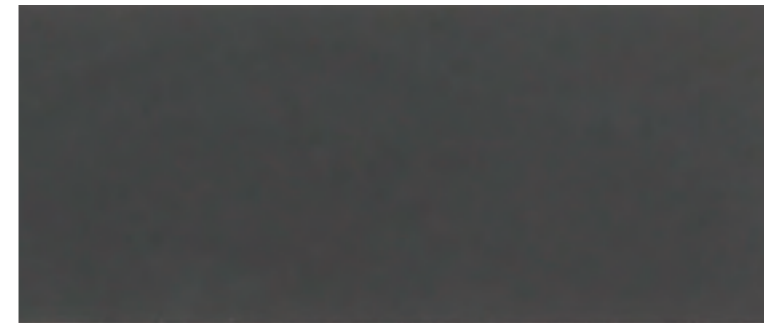

grigio grafite / graphite / grafito / Graphit GS

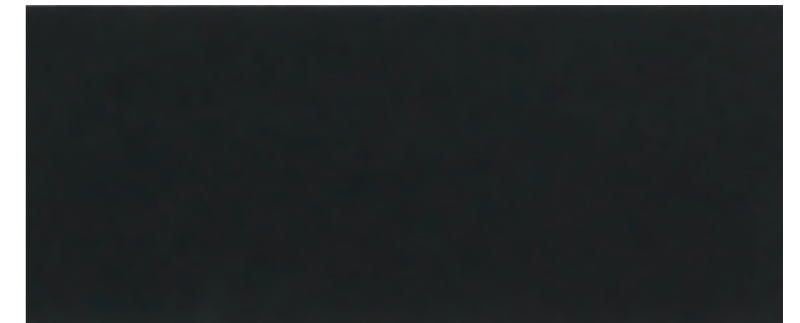

nero / black / negro / schwarz NE

ALUCOMPACT®
ALUCOMPACT®

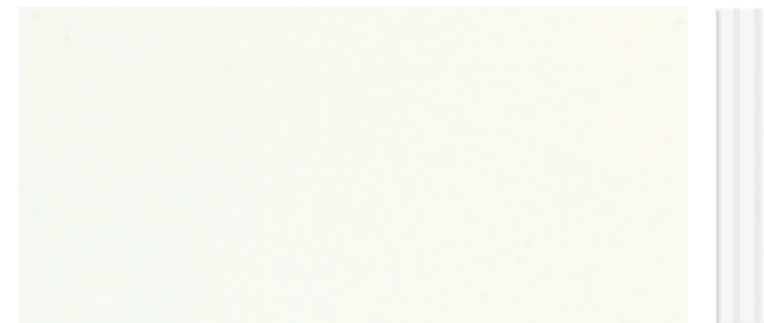

bianco / white / blanco / Weiß WH

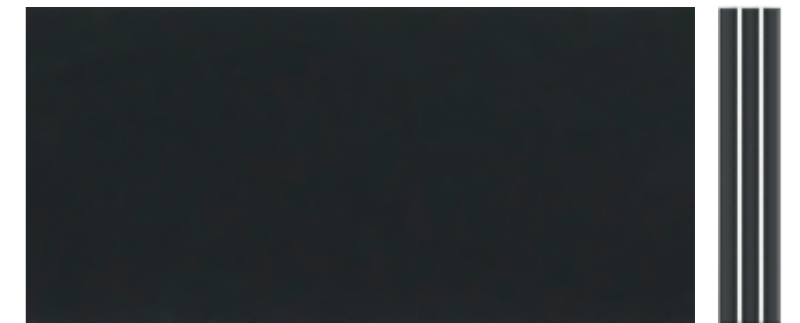

nero / black / negro / schwarz NE

I colori del campionario sono puramente indicativi e sono possibili differenze di tonalità tra una partita di produzione e l'altra.
All sample colours are merely indicative and there may be differences in shade between one production lot and the another.
Los colores del muestrario son meramente indicativos, pueden existir pequeñas diferencias de tonalidad de una partida de producción a otra.
Die Farbmuster sind reine Richtwerte. Die Farbtöne können von einer Produktionsreihe zur nächsten leicht variieren.

METALLI
METAL

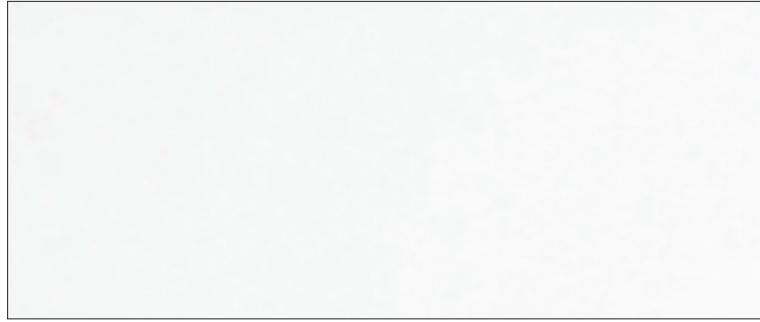

bianco / white / blanco / Weiß

WH



grigio grafite / graphite / grafito / Graphit

GS



cromo satinato / satin chrome / cromo satinado / seidenmatt verchromt

CS



alluminio ox brill / brill aluminium / aluminio brill / brill Aluminium

BR

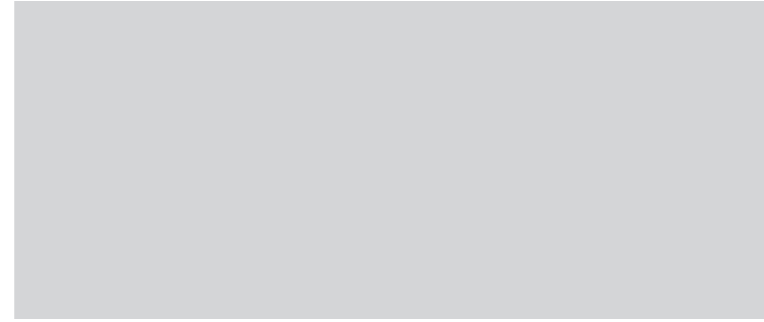

grigio polvere / dusty oak / gris polvoriento / staubgrau

GP



nero / black / negro / schwarz

NE



alluminio ox chimico / anodized aluminium / aluminio anodizado / eloxiertem Aluminium

OX



alluminio ox nero / black aluminium / aluminio negro / schwarz Aluminium

NEX

VETRI
GLASS

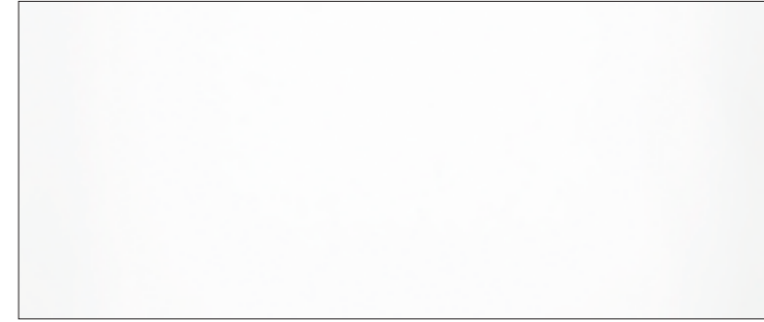

extra chiaro / extra white / blanco adicional / extra weiß

0A



grigio grafite / graphite / grafito / Graphit

95

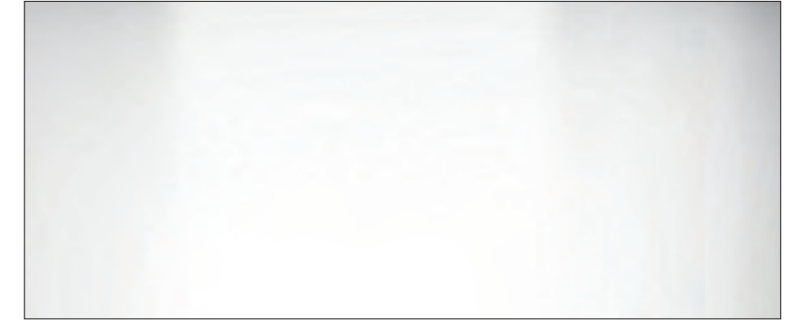

bianco / white / blanco / Weiß

01



grigio polvere / dusty oak / gris polvoriento / staubgrau

97



nero / black / negro / schwarz

02

TESSUTO RUBBER COLLECTION

RUBBER TEXTILE COLLECTION

COLLEZIONE RUBBER		08 / 02 / 2011		F1317	CAT. A	SCHEDA TECNICA			
caratteristiche characteristics	unita' / unit	risultati ottenuti sui campioni / results		rif. norme	caratteristiche characteristics	unita' / unit	risultati ottenuti sui campioni/results		rif. norme
altezza pezza Width	cm	145			Solidità della tinta Fastness	scala 1: 8	Alla luce / to light	4/5	UNI EN ISO 105 - B
Peso tessuto Weight	gr / ml	650				scala 1: 5	Allo Sfreg. secco To Dry Rubbing	4	UNI EN ISO 105 - X
Tintura / Dyeing	tipo / type	pezza				scala 1: 5	Allo Sfreg. umido To Wet Rubbing	4	UNI EN ISO 105 - X
IDROREPELENTE WATER REPELLENT		double				scala 1: 5	All'abrasione To abrasion	4	UNI EN ISO 12947
Tessitura Weaving	tipo / type	maglia				scala 1: 5	Al lavaggio a secco To Dry cleaning	4	UNI EN ISO 105 - D
Composizione Composition	%	80% PA - 20% EA			scala 1: 5	Al lavaggio in acqua To washing	4	UNI EN ISO 105 - C	
Resistenza alla trazione tensile Tensile (breaking) strenght	N (1Kg. =9,8 Newton)	Ordito / Warp	Trama / Weft	UNI EN ISO 13934 - 1	Manutenzione Maintenance	Ritiri al lavaggio in acqua Shrinkage water 30°	Ordito / Warp	Trama / Weft	
Resistenza alla lacerazione Tear strenght	N (1Kg. =9,8 Newton)	Ordito / Warp	Trama / Weft	UNI EN ISO 13937 - 3			1,0 %	1,0 %	
Resistenza allo slittamento dei fili-6 mm Seam slippage-6 mm.	N (1Kg. =9,8 Newton)	Ordito / Warp	Trama / Weft	UNI EN ISO 13936 - 2		Ritiri al lavaggio a secco / Shrinkage dry	Ordito / Warp	Trama / Weft	
Usura Martindale Abrasion	n° cicli / n°	20.000		UNI EN ISO 12947 - 2			1,0 %	1,0 %	
Pilling al Martindale	n° cicli / n°	5		UNI EN ISO 12945 - 2					



NOTA TECNICA:

Tessuto double-face. Gli abbinamenti colore proposti sono obbligatori; Il codice di riferimento utilizzato identifica il colore dominante del prodotto

es: codice tessuto 01
rivestimento parte anteriore con tessuto DOUBLE ghiaccio e posteriore polvere

es: codice tessuto 11
rivestimento parte anteriore con tessuto DOUBLE polvere e posteriore ghiaccio

Per utilizzare un solo colore aggiungere la dicitura MONO

es: codice tessuto 01 GHIACCIO
rivestimento parte anteriore e posteriore con tessuto DOUBLE ghiaccio

TECHNICAL INFORMATION:

Double-face fabric. The combination of the colours can be only as proposed. The code identifies the dominant colour

Ex. fabric code 01
Front covered with Double Fabric Ice-like colour; back covered with fabric dust-like colour.

Ex. fabric code 11
Front covered with Double Fabric dust-like colour; back covered with fabric Ice-like colour.

If you intend to choose a single colour, please add to the code the words MONO

Ex. fabric code 01 ICE-LIKE COLOUR

NOTA TÉCNICA:

Tejido 'double-face'. Hay que elegir dentro de las combinaciones de colores propuestas. El código de referencia utilizado identifica la color dominante del producto.

Por ejemplo si la parte anterior está tapizada con tejido DOUBLE color hielo y la trasera con tejido color polvo el código correspondiente es: tejido 01. Si por otro lado la parte anterior está tapizada con tejido DOUBLE color polvo y la trasera con tejido color hielo el código correspondiente es: tejido 11.

Para utilizar una sola color añadir la expresión 'MONO'.

Por ejemplo si ambas la parte anterior y la de atrás están tapizadas con tejido DOUBLE color hielo el código de utilizar es : tejido 01 HIELO.

TECHNISCHE ANMERKUNG:

Umgewendet Gewebe. Die gedachte Kombinationen der Farben sind obligatorische. Die Code der Beziehung, die benützt wird, die dominante Farbe des Artikels identifiziert.

Zum Beispiel, die Code 'Gewebe 01' identifiziert die Askleidung des voriges Teil mit DOUBLE Gewebe in der Eis Farbe und des Rück-Teil mit DOUBLE Gewebe in der Staub Farbe. Die Code 'Gewebe 11' identifiziert die Askleidung des voriges Teil mit DOUBLE Gewebe in der Staub Farbe und des Rück-Teil mit DOUBLE Gewebe in der Eis Farbe.

Eine einzige Farbe zu benützen, die Wort 'MONO' anfügen.

Zum Beispiel, die Code 'Gewebe 01 EIS' zeigt die Askleidung des beides voriges Teil und Rück-Teil mit DOUBLE Gewebe in der Eis Farbe an.

I colori del campionario sono puramente indicativi e sono possibili differenze di tonalità tra una partita di produzione e l'altra.

All sample colours are merely indicative and there may be differences in shade between one production lot and the another.

Los colores del muestrario son meramente indicativos, pueden existir pequeñas diferencias de tonalidad de una partida de producción a otra.

Die Farbmuster sind reine Richtwerte. Die Farbtöne können von einer Produktionsreihe zur nächsten leicht variieren.



09 bianco / white / blanco / Weiß

nero / black / negro / schwarz 19



02 viola / purple / púrpura / lila

sabbia / sand / arena / Sand 12



01 magenta / magenta / magenta / Magenta

blu / blue / azul / blau 11



08 rosso / red / rojo / rot

indaco / indigo / añil / Indigo 18

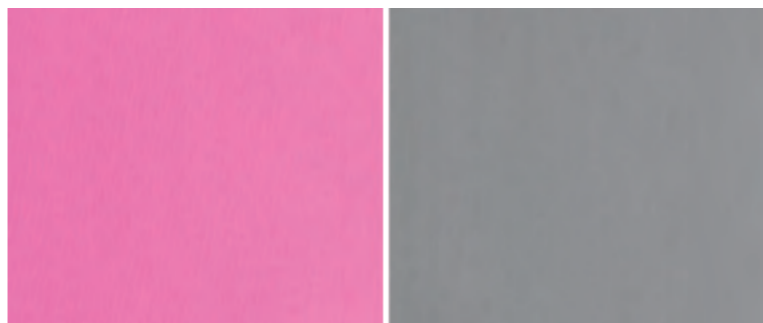

10 fucsia / fuchsia / fucsia / Fuchsia

creta / clay / arcilla / Lehm 20

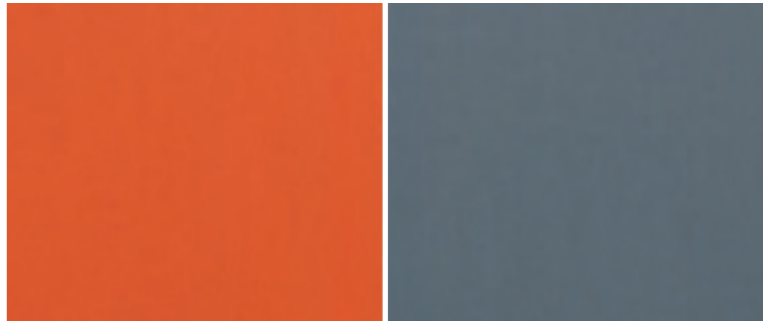

06 arancio / orange / naranja / orange

ardesia / slate / pizarra / Schiefer 16

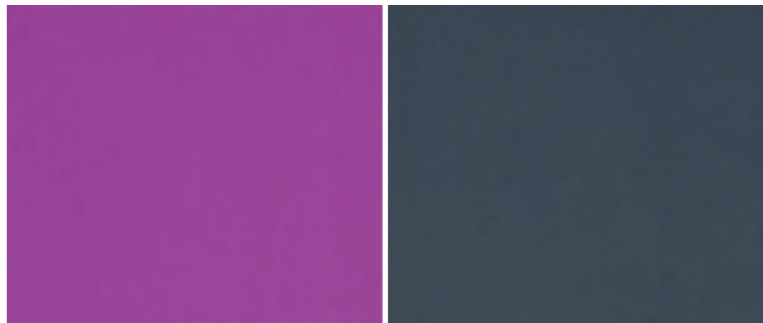

03 glicine / wisteria / glicina / Glyzinien

grafite / graphite / grafito / Graphit 13



04 azzurro / light blu / luz azul / hellblau

marrone / brown / marrón / braun 14



07 giallo / yellow / amarillo / Gelb

lilla / lilac / lila / Flieder 17



05 lime / lime / cal / Kalk

kaki / khaki / kaki / kaki 15

TESSUTO FLIGHT COLLECTION

FLIGHT TEXTILE COLLECTION

COLLEZIONE FLIGHT		16 / 02 / 2011				F1285	CAT. B	SCHEMA TECNICA				
caratteristiche characteristics	unita' / unit	risultati ottenuti sui campioni / results				rif. norme	caratteristiche characteristics	unita' / unit	risultati ottenuti sui campioni/results		rif. norme	
altezza pezza Width	cm	140					Solidità della tinta Fastness	scala 1: 8	Alla luce / to light	4 / 5	UNI EN ISO 105 - B02	
Peso tessuto Weight	gr / ml	580						scala 1: 5	Allo Sfreg. secco To Dry Rubbing	4	UNI EN ISO 105 - X12	
Tintura / Dyeing	tipo / type	tinto in filo						scala 1: 5	Allo Sfreg. umido To Wet Rubbing	4	UNI EN ISO 105 - X12	
IDROREPELENTE - ANTIMACCHIA - TRASPIRANTE												
Tessitura Weaving	tipo / type	jaquard						scala 1: 5	All'abrasione To abrasion	4 / 5	UNI EN ISO 12947 - 2	
Composizione Composition	%	81% PL - 12% CO - 7% PC					scala 1: 5	Al lavaggio a secco To Dry cleaning	4	UNI EN ISO 105 - D01		
Resistenza alla trazione tessile Tensile (breaking) strenght	N (1Kg. =9,8 Newton)	Ordito Warp	2500	Trama Weft	590	UNI EN ISO 13934 - 1	Manutenzione Maintenance	Ritiri al lavaggio in acqua Shrinkage water 30°	Ordito / Warp	Trama / Weft		
Resistenza alla lacerazione Tear strenght	N (1Kg. =9,8 Newton)	Ordito Warp	80	Trama Weft	200	UNI EN ISO 13937 - 3			1,0 %	1,0 %		
Resistenza allo slittamento dei fili-6 mm Seam slippage-6 mm.	N (1Kg. =9,8 Newton)	Ordito Warp	180	Trama Weft	180	UNI EN ISO 13936 - 2		Ritiri al lavaggio a secco / Shrinkage dry	Ordito / Warp	Trama / Weft		
Usura Martindale Abrasion	n° cicli n° cycles	> 20.000				UNI EN ISO 12947 - 2			0,0 %	0,5 %		
Pilling al Martindale	n° cicli n° cycles	4 / 5				UNI EN ISO 12945 - 2	Resistenza al fuoco Flame resistance	si può ignifugare			BS 5852:1979 PART 1	



I colori del campionario sono puramente indicativi e sono possibili differenze di tonalità tra una partita di produzione e l'altra.

All sample colours are merely indicative and there may be differences in shade between one production lot and the another.

Los colores del muestrario son meramente indicativos, pueden existir pequeñas diferencias de tonalidad de una partida de producción a otra.

Die Farbmuster sind reine Richtwerte. Die Farbtöne können von einer Produktionsreihe zur nächsten leicht variieren.



06



13



32



28



15



27

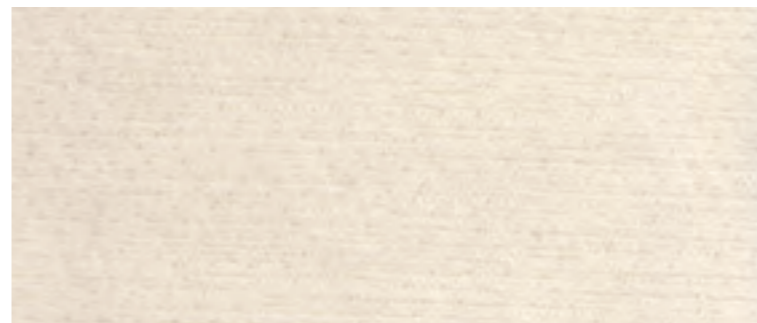

35



18

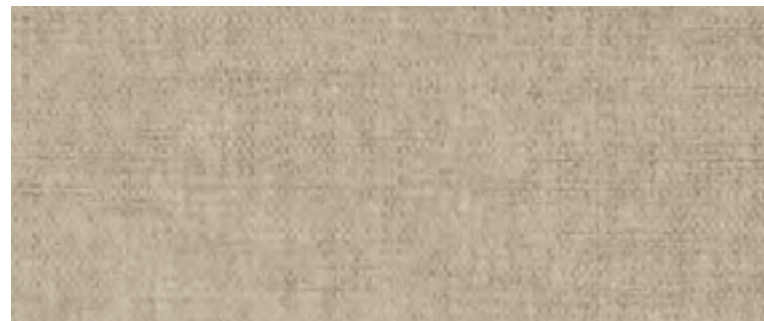

03



08



01

TESSUTO BONGO

BONGO TEXTILE COLLECTION

COLLEZIONE BONGO		12 / 01 / 2011				F1311	CAT. C	SCHEDA TECNICA				
caratteristiche characteristics	unita' / unit	risultati ottenuti sui campioni / results				ref. norme	caratteristiche characteristics	unita' / unit	risultati ottenuti sui campioni/results		ref. norme	
altezza pezza Width	cm	138 / 140					Solidità della tinta Fastness	scala 1: 8	Alla luce / to light	3 / 4	UNI EN ISO 105 - B02	
Peso tessuto Weight	gr / ml	800						scala 1: 5	Allo Sfreg. secco To Dry Rubbing	3 / 4	UNI EN ISO 105 - X12	
Tintura / Dyeing	tipo / type	tinto in filo						scala 1: 5	Allo Sfreg. umido To Wet Rubbing	3 / 4	UNI EN ISO 105 - X12	
Tessitura Weaving	tipo / type							scala 1: 5	All'abrasione To abrasion	3 / 4	UNI EN ISO 12947 - 2	
Composizione Composition	%	90% PL - 3 % CO - 7% LI						scala 1: 5	Al lavaggio a secco To Dry cleaning	3 / 4	UNI EN ISO 105 - D01	
Resistenza alla trazione tessile Tensile (breaking) strenght	N (1Kg. =9,8 Newton)	Ordito Warp	2000	Trama Weft	1400	UNI EN ISO 13934 - 1	Manutenzione Maintenance	Ritiri al lavaggio in acqua Shrinkage water 30°	Ordito / Warp	Trama / Weft		
Resistenza alla lacerazione Tear strenght	N (1Kg. =9,8 Newton)	Ordito Warp	300	Trama Weft	300	UNI EN ISO 13937 - 3				1,0 %	1,0 %	
Resistenza allo slittamento dei fili-6 mm Seam slippage-6 mm.	N (1Kg. =9,8 Newton)	Ordito Warp	2,5	Trama Weft	2,5	UNI EN ISO 13936 - 2			Ritiri al lavaggio a secco / Shrinkage dry	Ordito / Warp	Trama / Weft	
Usura Martindale Abrasion	n° cicli n° cycles	> 20.000				UNI EN ISO 12947 - 2				0,5 %	0,5 %	
Pilling al Martindale	n° cicli n° cycles	4 / 5				UNI EN ISO 12945 - 2						



01

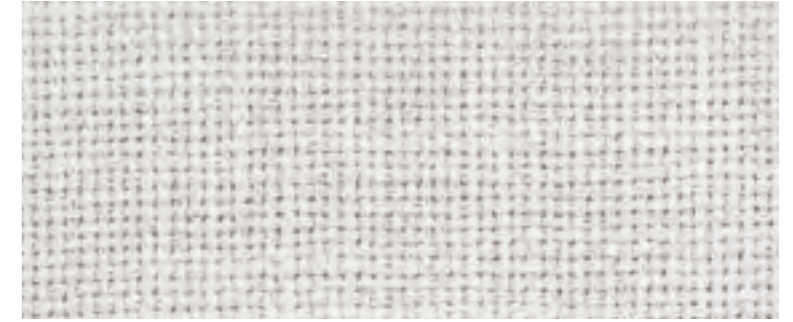

02



03

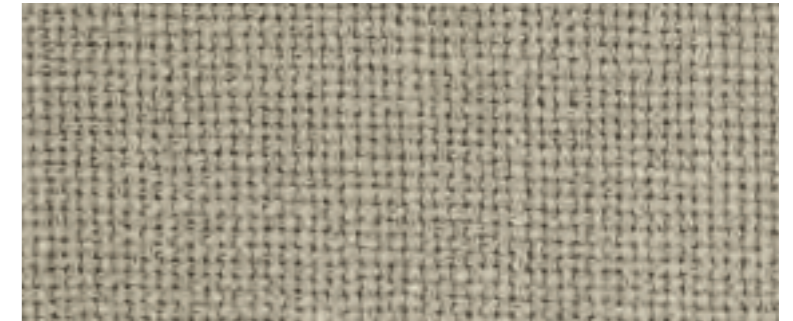

10

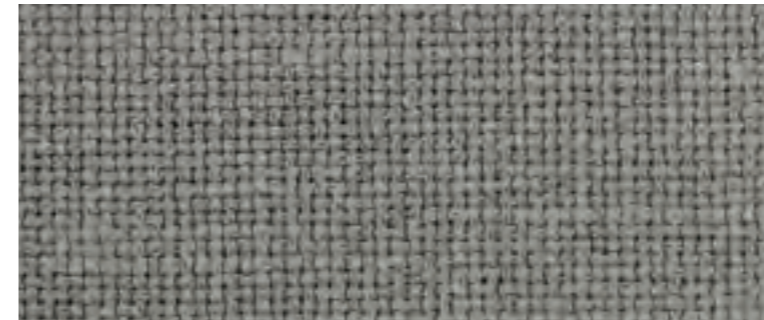

12

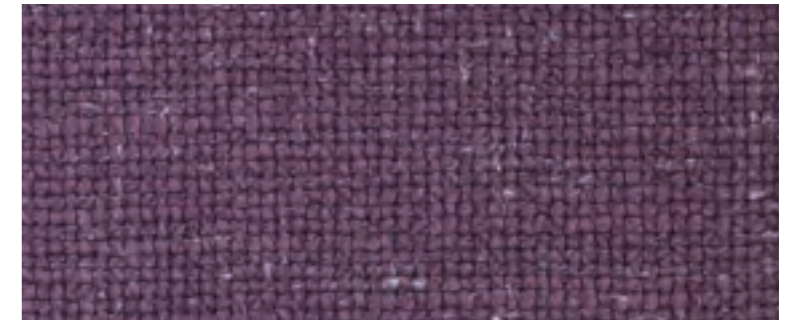

08



13

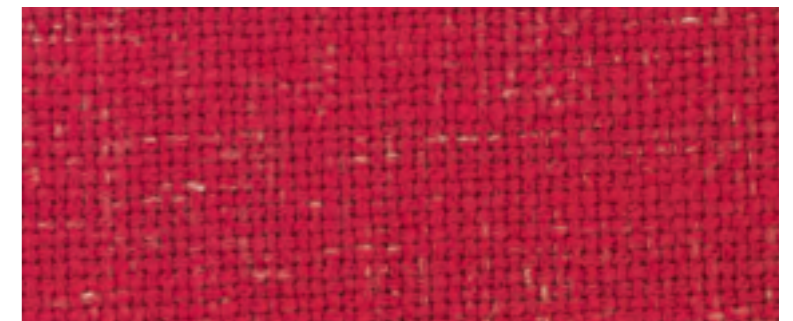

07

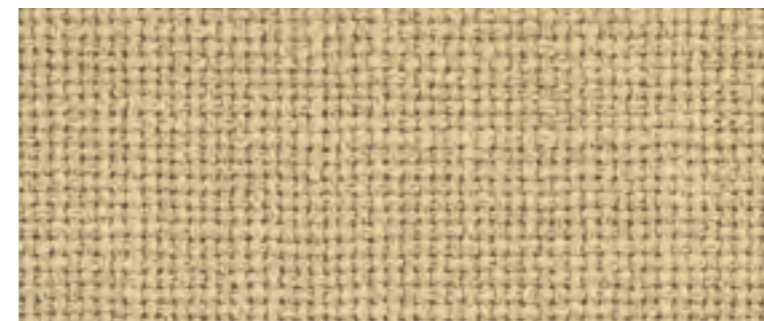

04

I colori del campionario sono puramente indicativi e sono possibili differenze di tonalità tra una partita di produzione e l'altra.

All sample colours are merely indicative and there may be differences in shade between one production lot and the another.

Los colores del muestrario son meramente indicativos, pueden existir pequeñas diferencias de tonalidad de una partida de producción a otra.

Die Farbmuster sind reine Richtwerte. Die Farbtöne können von einer Produktionsreihe zur nächsten leicht variieren.

TESSUTO DOUBLE

DOUBLE TEXTILE COLLECTION

COLLEZIONE BONGO		14 / 01 / 2011				F1306	CAT. D	SCHEDA TECNICA			
caratteristiche characteristics	unita' / unit	risultati ottenuti sui campioni / results				rif. norme	caratteristiche characteristics	unita' / unit	risultati ottenuti sui campioni/results		rif. norme
altezza pezza Width	cm	138 / 140					Solidità della tinta Fastness	scala 1: 8	Alla luce / to light	> 4	UNI EN ISO 105 - B02
Peso tessuto Weight	gr / ml	650						scala 1: 5	Allo Sfreg. secco To Dry Rubbing	> 4	UNI EN ISO 105 - X12
Tintura / Dyeing	tipo / type	tinto in pezza						scala 1: 5	Allo Sfreg. umido To Wet Rubbing	3 / 4	UNI EN ISO 105 - X12
								scala 1: 5	All'abrasione To abrasion	3 / 4	UNI EN ISO 12947 - 2
								scala 1: 5	Al lavaggio a secco To Dry cleaning	> 4	UNI EN ISO 105 - D01
Tessitura Weaving	tipo / type	piana					Manutenzione Maintenance	scala 1: 5	Al lavaggio in acqua To washing	3 / 4	UNI EN ISO 105 - C06
Composizione Composition	%	80% PA - 20% EA						Pitri al lavaggio in acqua Shrinkage water 30°	Ordito / Warp	Trama / Weft	
Resistenza alla trazione tessile Tensile (breaking) strenght	N (1Kg. =9,8 Newton)	Ordito Warp	1400	Trama Weft	1400	UNI EN ISO 13934 - 1				1,0 %	1,0 %
Resistenza alla lacerazione Tear strenght	N (1Kg. =9,8 Newton)	Ordito Warp	200	Trama Weft	220	UNI EN ISO 13937 - 3		Ritiri al lavaggio a secco / Shrinkage dry	Ordito / Warp	Trama / Weft	
Resistenza allo slittamento dei fili-6 mm Seam slippage-6 mm.	N (1Kg. =9,8 Newton)	Ordito Warp	>180	Trama Weft	>180	UNI EN ISO 13936 - 2				0,0 %	0,0 %
Usura Martindale Abrasion	n° cicli n° cycles	> 20.000				UNI EN ISO 12947 - 2	Resistenza al fuoco Flame resistance				BS 5852:1979 PART 1
Pilling al Martindale	n° cicli n° cycles	4 / 5				UNI EN ISO 12945 - 2					



NOTA TECNICA:

Tessuto double-face. Gli abbinamenti colore proposti sono obbligatori; Il codice di riferimento utilizzato identifica il colore dominante del prodotto

es: codice tessuto 01 rivestimento parte anteriore con tessuto DOUBLE ghiaccio e posteriore polvere

es: codice tessuto 11 rivestimento parte anteriore con tessuto DOUBLE polvere e posteriore ghiaccio

Per utilizzare un solo colore aggiungere la dicitura MONO

es: codice tessuto 01 GHIACCIO rivestimento parte anteriore e posteriore con tessuto DOUBLE ghiaccio



01 ghiaccio / ice / hielo / Eis

polvere / dust / polvo / Staub 11

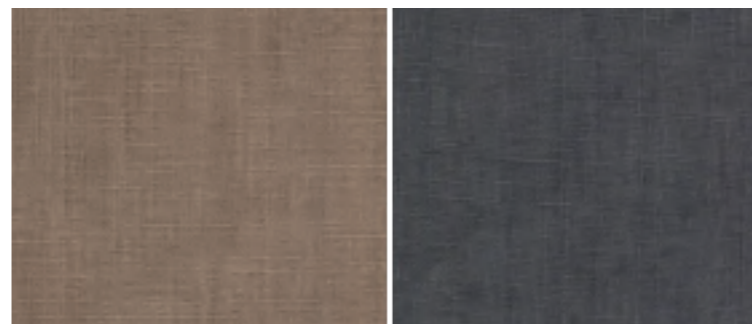

05 castagna / chestnut / castaño / Kastanie

grafite / graphite / grafito / Graphit 15



03 ekrü / ekru / crudo / ekrü

ocra / ocher / ocre / Ocker 13

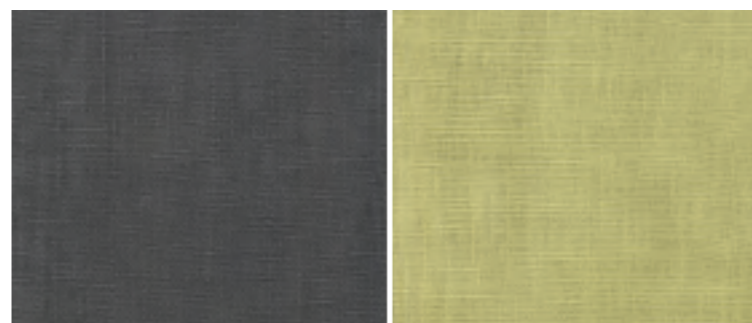

06 seppia / cuttlefish / sepia / Tintenfisch

lime / lime / cal / Kalk 16

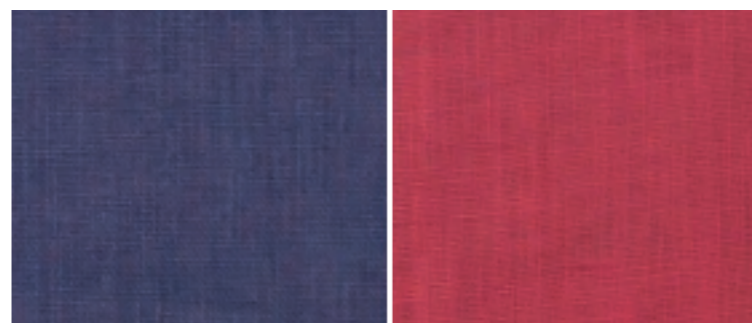

08 viola / purple / púrpura / lila

rosso scuro / dark red / rojo oscuro / dunkelrote 18

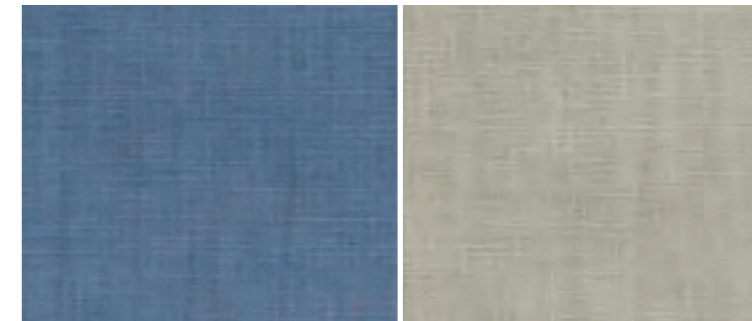

09 denim / denim / drill / Denim

avorio / ivory / marfil / Elfenbein 19

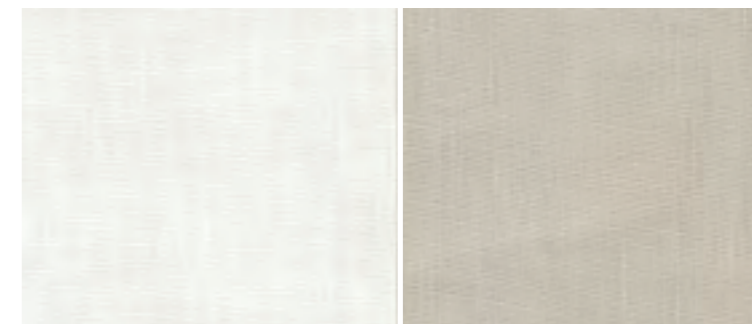

02 bianco / white / blanco / Weiß

beige / beige / beige / beige 12

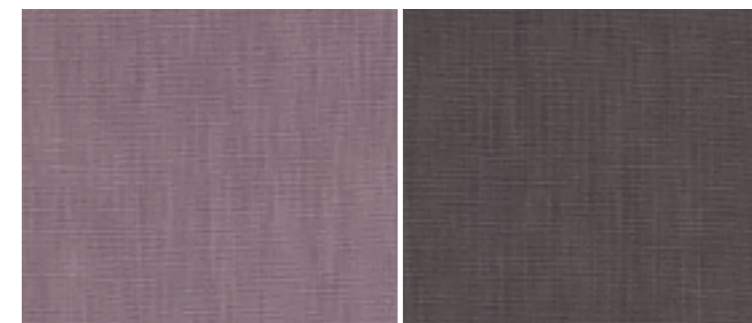

07 violetto / violet / violeta / Violett

fango / mud / barro / Schlamm 17



04 basalto / basalt / basalto / Basalt

rubino / ruby / rubi / Rubin 14

I colori del campionario sono puramente indicativi e sono possibili differenze di tonalità tra una partita di produzione e l'altra.

All sample colours are merely indicative and there may be differences in shade between one production lot and the another.

Los colores del muestrario son meramente indicativos, pueden existir pequeñas diferencias de tonalidad de una partida de producción a otra.

Die Farbmuster sind reine Richtwerte. Die Farbtöne können von einer Produktionsreihe zur nächsten leicht variieren.

PELLE
LEATHER

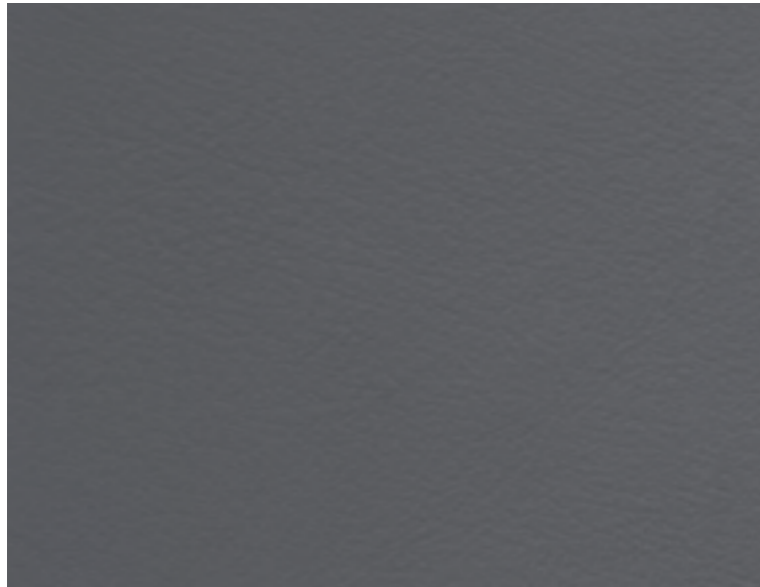

grigio metallo / iron grey / hierro gris/ eisengrau L04

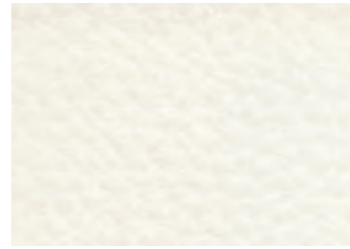

bianco / white / blanco / Weiß L01

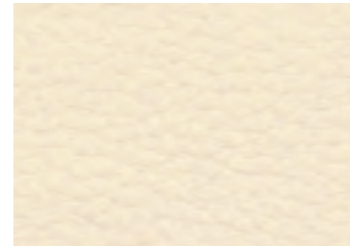

bianco caldo / warm white / blanco cálido / warmweiß L00



mururoa / mururoa / mururoa / mururoa L68



turchese / turquoise / turquesa / Türkis L69



abisso / abyss / abismo / Abgrund L75



lavanda / lavender / lavanda / Lavendel L82

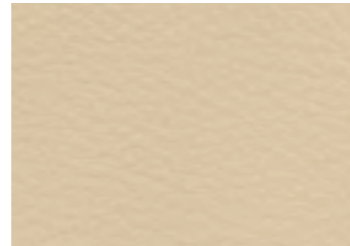

sabbia / sand / arena / Sand L19

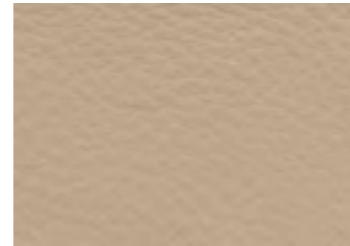

zanna / zanna / zanna / zanna

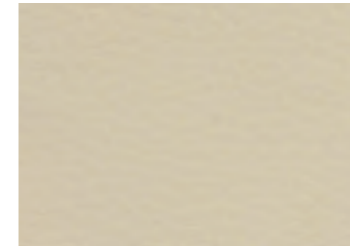

polvere / dust / polvo / Staub L08

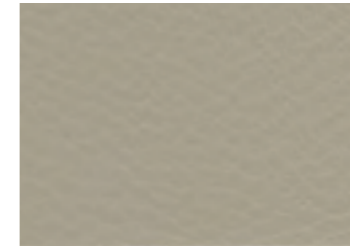

tartaruga / turtle / tortuga / Schildkröte L09

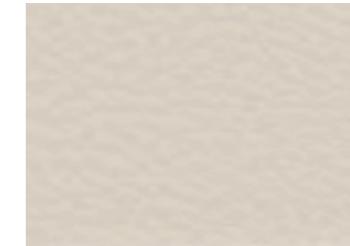

pietra / stone / piedra / Stein L10

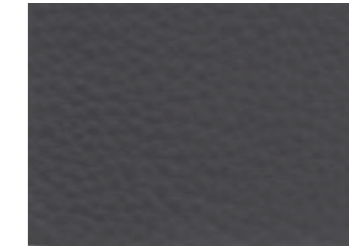

grafite / graphite / grafito / Graphit L11



cervo / deer / ciervos / Hirsch L16

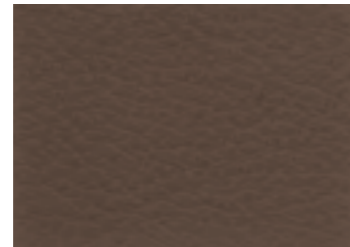

torba / peat / turba / Torf L17

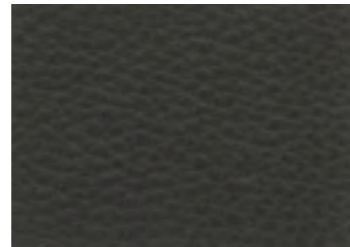

moro / moor / páramo / Moor L98



beccocca / spout / caño / Ausguss L46

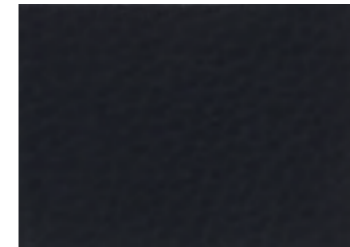

nero / black / negro / schwarz L07



pappagallo / parrot / loro / Papagei L47



fuoco / fire / fuego / Feuer L48

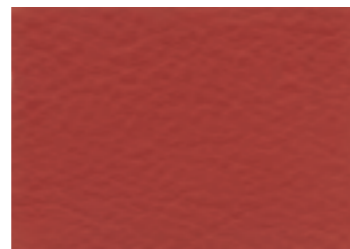

begonia / begonia / begonia / Begonie L40



porpora / purpura / púrpura / lila L83

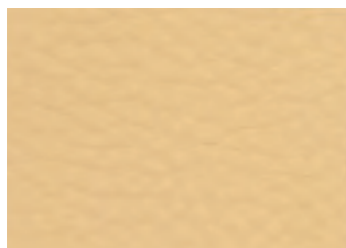

banana / banana / banana / Banane L49



ulivo / olive / oliva / Olivenöl L55

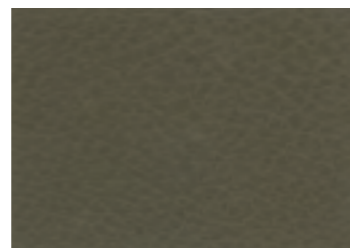

soldato / soldier / soldado / Soldat L57



lime / lime / cal / Kalk L94

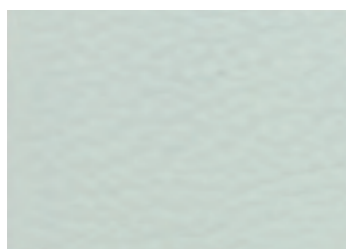

aqua / aqua / aqua / aqua L64

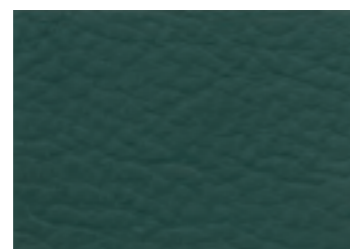

ottanio / teal / cerceta / Krickente L66

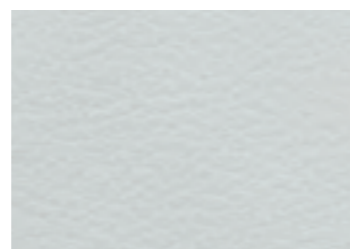

ghiaccio / ice / hielo / Eis L76

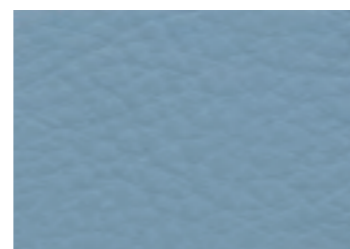

artico / arctic / ártico / Arktis L77

I colori del campionario sono puramente indicativi e sono possibili differenze di tonalità tra una partita di produzione e l'altra.
All sample colours are merely indicative and there may be differences in shade between one production lot and the another.
Los colores del muestrario son meramente indicativos, pueden existir pequeñas diferencias de tonalidad de una partida de producción a otra.
Die Farbmuster sind reine Richtwerte. Die Farbtöne können von einer Produktionsreihe zur nächsten leicht variieren.

TOP PELLE
TOP LEATHER



bianco classico / classic white P4
blanco clásico / klassischem Weiß



baobab / baobab / baobab / baobab P3



fango / mud / barro / Schlamm P1



pull up / pull up / pull up / pull up P2

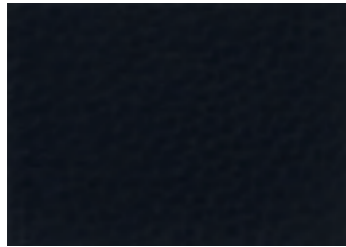

nero classico / classic black P5
negro clásico / klassischem schwarz

CUOIO
HIDE



naturale / natural / naturales / natürliche

18

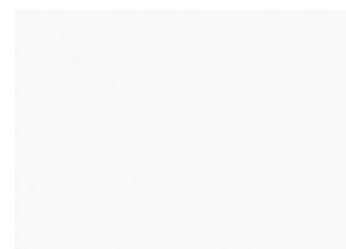

bianco / white / blanco / Weiß 14

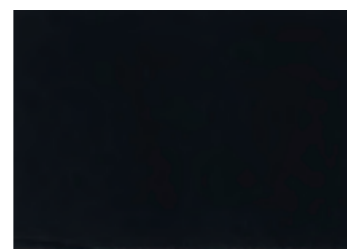

nero / black / negro / schwarz 12

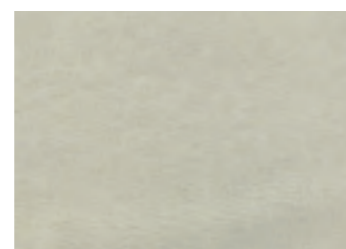

ghiaccio / ice / hielo / Eis 17



castagna / chestnut L19
castaño / Kastanie

ECO - PELLE
ECO - LEATHER



testa moro / dark brown / marrón oscuro / dunkelbraun E45

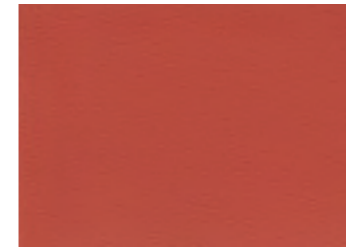

arancio / orange / naranja / orange E37

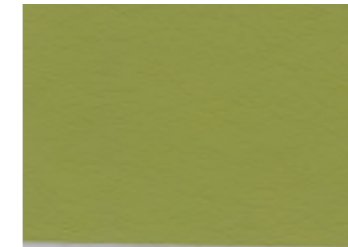

verde acido / light green E80
luz verde / hellgrün



blu / blue / azul / blau E75



grigio / gray / gris / grau E60



bianco / white / blanco / Weiß E11

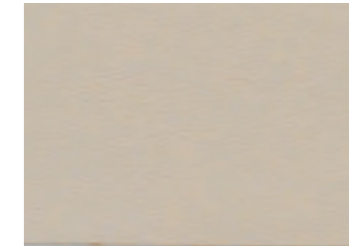

beige / beige / beige / beige E43

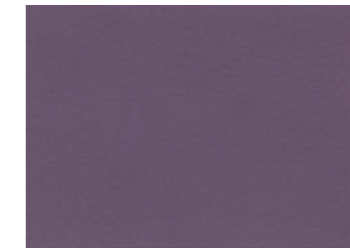

glicine / wisteria / glicina / Glyzinien E03



rosso / red / rojo / rot E30

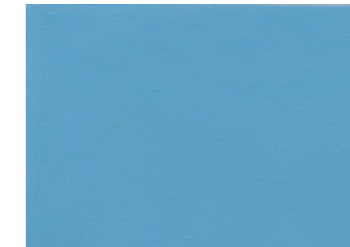

celeste / air / aire / Luft E70



azzurro / light blu / luz azul / hellblau E79

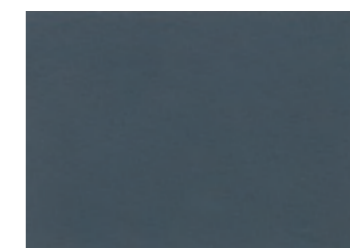

grafite / graphite / grafito / Graphit E61

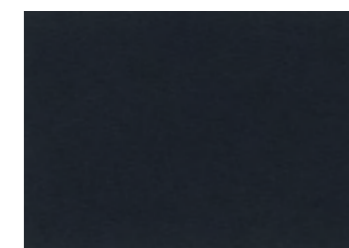

nero / black / negro / schwarz E20

I colori del campionario sono puramente indicativi e sono possibili differenze di tonalità tra una partita di produzione e l'altra.
All sample colours are merely indicative and there may be differences in shade between one production lot and the another.
Los colores del muestrario son meramente indicativos, pueden existir pequeñas diferencias de tonalidad de una partida de producción a otra.
Die Farbmuster sind reine Richtwerte. Die Farbtöne können von einer Produktionsreihe zur nächsten leicht variieren.

ABACO TECNICO

ABACUS TECHNICAL
ÁBACO TÉCNICA
ABAKUS TECHNISCHE

Chiuso_Closed_Cerrado_Geschlossen / Aperto_Open_abierto_offen

cm 115 X 80 H 77 / cm 165 X 80 H 77
 cm 140 X 80 H 77 / cm 190 X 80 H 77 / cm 240 X 80 H 77
 cm 140 X 90 H 77 / cm 190 X 90 H 77 / cm 240 X 90 H 77
 cm 160 X 90 H 77 / cm 210 X 90 H 77 - cm 260 X 90 H 77
 cm 180 X 90 H 77 / cm 230 X 90 H 77 - cm 280 X 90 H 77

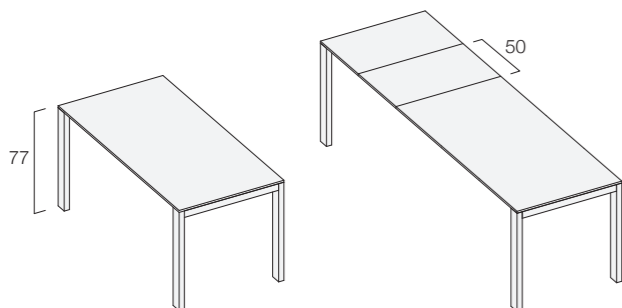

Tavolo allungabile con struttura in metallo laccato o cromo satinato, piano laminato, vetro, MDF impiallacciato frassino o Alucompact®

FINITURA BASAMENTO:

metallo laccato bianco, nero, grigio grafite, grigio polvere o cromo-satinato.

FINITURA PIANO:

laminato (varianti come da campionario material), / vetro extra chiaro laccato bianco, nero, grigio grafite e grigio polvere / MDF impiallacciato frassino sbiancato naturale, tinto grigio, tinto tabacco, tinto moro o laccata poro aperto bianco, nero, grigio grafite, grigio polvere / Alucompact® bianco o nero.

Ausziehtisch mit Metall oder lackierten Aluminium Aufbau, Walztischplatte, Glas, furnierten Esche MDF oder Alucompact.

AUFBAU:

weiß, schwarz, graphitgrau, staubgrau lackierter Metall.

TISCHPLATTE:

Walztischplatte (Varianten als im Werkstoffmusterbuch), Extrahell weiß, schwarz, graphitgrau und staubgrau lackiertes Glas / Naturgebleichte, graufarbige, tabakfarbene, schwarzfarbige furnierter Esche MDF oder weiß, schwarz, graphitgrau, staubgrau lackierte offene Pore Tischplatte / weißer oder schwarzer Alucompact.

Mesa extensible con estructura en metal y aluminio lacado. Tapa en laminado, cristal, MDF contrachapado en fresno o Alucompact.

ESTRUCTURA:

metal lacado blanco, negro, gris grafito o gris polvo.

TAPA:

laminado (en los variantes del muestrario) /cristal extra claro lacado color blanco, negro, gris grafito, gris polvo / MDF contrachapado en fresno blanqueado natural, gris, tabaco, marrón o lacado poro abierto color blanco, negro, gris grafito, gris polvo / Alucompact blanco o negro.

Extensible table with structure in metal and aluminium lacquered. Top available in laminated, glass, MDF ash veneered, Alucompact

STRUCTURE FINISHINGS:

metal lacquered in the colours white, black , graphite-like grey and dust-like grey.

TOP FINISHINGS:

laminated (in the finishings as sample book), extra clear glass lacquered in the colours white, black, graphite-like grey and dust-like grey / MDF ash veneered in the colours bleached natural ash, grey, tobacco, dark brown / open pore lacquered in the colours white, black, graphite-like grey, dust-like grey / Alucompact white or black.

Chiuso_Closed_Cerrado_Geschlossen / Aperto_Open_abierto_offen

cm 115 X 80 H 76 / cm 165 X 80 H 76
 cm 140 X 80 H 76 / cm 190 X 80 H 76
 cm 140 X 90 H 76 / cm 190 X 90 H 76
 cm 160 X 90 H 77 / cm 210 X 90 H 76 - cm 260 X 90 H 76
 cm 180 X 90 H 77 / cm 230 X 90 H 76 - cm 280 X 90 H 76

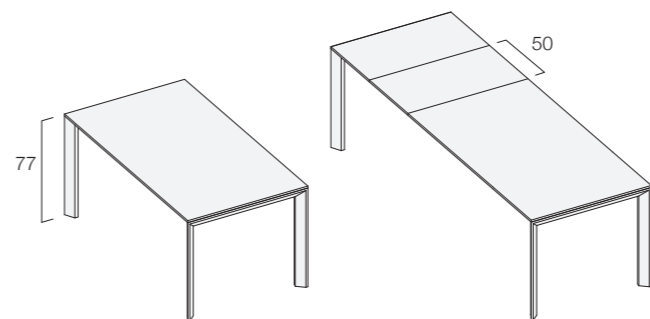

Tavolo con struttura in metallo laccato o cromo satinato, particolare in metallo laccato o cromosatinato o in frassino (varianti come da campionario material), piano in vetro o MDF impiallacciato frassino

FINITURA BASAMENTO:

Metallo laccato bianco, nero, grigio grafite, cromo satinato con particolare in tinta o particolare in frassino sbiancato naturale, tinto grigio, tinto tabacco, tinto moro o laccato poro aperto bianco, nero ,grigio grafite, grigio polvere.

FINITURA PIANO:

laminato (varianti come da campionario material), / vetro extra chiaro laccato bianco, nero, grigio grafite e grigio polvere / MDF impiallacciato frassino sbiancato naturale, tinto grigio, tinto tabacco, tinto moro o laccata poro aperto bianco, nero, grigio grafite, grigio polvere / Alucompact® bianco o nero

Ausziehtisch mit lackierten Aluminium Aufbau, Walztischplatte, Glas, furnierter Esche MDF oder Alucompact.

STRUCTURE FINISHINGS:

weiß, schwarz, graphitgrau, staubgrau lackierter oder elaxierter Aluminium.

TOP FINISHINGS:

Walztischplatte (Varianten als im Werkstoffmusterbuch), Extrahell weiß, schwarz, graphitgrau, staubgrau lackiertes Glas / Naturgebleichte, graufarbige, tabakfarbene, schwarzfarbige furnierte Esche MDF oder weiß, shwarz, graphitgrau, staubgrau lackierte offene Pore Tischplatte / weißer oder schwarzer Alucompact.

Mesa extensible con estructura en aluminio lacado o bien anodizado. Tapa en laminado, cristal, MDF contrachapado en fresno o Alucompact.

ESTRUCTURA:

aluminio lacado colores blanco, negro, gris grafito, gris polvo.

TAPA:

laminado (en los variantes del muestrario)/ cristal extra claro lacado color blanco, negro, gris grafito, gris polvo/ MDF contrachapado en fresno blanqueado natural, gris, tabaco, marrón o lacado poro abierto color blanco, negro, gris grafito, gris polvo/Alucompact blanco o negro

Extensible table with aluminium lacquered structure. Top available in laminated, glass, MDF ash veneered, Alucompact

STRUCTURE FINISHINGS:

aluminium in the colours white, black, graphite-like grey, dust-like grey lacquered.

TOP FINISHINGS:

laminated (in the finishings as sample book), extra clear glass lacquered in the colours white, black, graphite-like grey and dust-like grey/ MDF ash veneered in the colours bleached natural ash, grey, tobacco, dark brown/ open pore lacquered in the colours white, black, graphite-like grey, dust-like grey/ Alucompact white or black.

Chiuso_Closed_Cerrado_Geschlossen / Aperto_Open_abierto_offen

cm 160 X 90 H 77 / cm 210 X 90 H 77 - cm 260 X 90 H 77
 cm 180 X 90 H 77 / cm 230 X 90 H 77 - cm 280 X 90 H 77
 cm 210 X 100 H 77 / cm 260 X 100 H 77 - cm 310 X 100 H 77

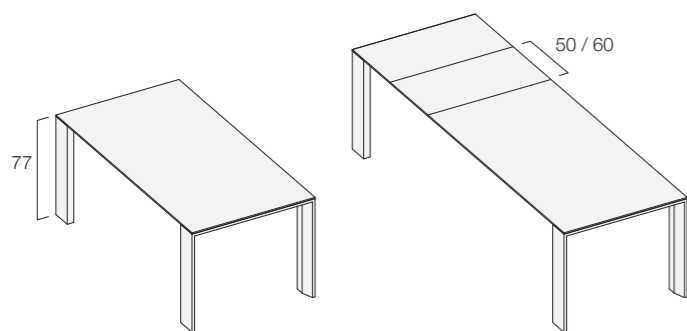

Tavolo allungabile con base in frassino, struttura tecnica in alluminio, piano in vetro, MDF impiallacciato frassino o Alucompact®

FINITURA BASAMENTO:

frassino sbiancato naturale, tinto grigio, tinto tabacco, tinto moro o laccato poro aperto bianco, nero, grigio grafite, grigio polvere.

FINITURA PIANO:

vetro extra chiaro laccato bianco, nero, grigio grafite e grigio polvere / MDF impiallacciato frassino sbiancato naturale, tinto grigio, tinto tabacco, tinto moro o laccato poro aperto bianco, nero, grigio grafite, grigio polvere / Alucompact® bianco o nero

Ausziehtisch mit Esche Beine, Öffnungmechanismus in Aluminium, Glas Tischplatte, furnierter Esche MDF oder Alucompact.

BASIS:

Naturgebleichte, graufarbige, tabakfarbene, schwarzfarbige Esche oder weiß, schwarz, graphitgrau, staubgrau lackierte offene Pore.

TISCHPLATTE:

Extrahell weiß, schwarz, graphitgrau, staubgrau lackiertes Glas / Naturgebleichte, graufarbige, tabakfarbene, schwarzfarbige furnierte Esche MDF oder weiß, schwarz, graphitgrau, staubgrau lackierte offene Pore Basis / weißer oder schwarzer Alucompact.

Mesa extensible con base en fresno, estructura tecnica en aluminio. Tapa en cristal, MDF contrachapado en fresno o Alucompact.

ESTRUCTURA:

fresno blanqueado natural, gris grafito, tabaco, marron o lacado poro abierto color blanco, negro, gris grafito, gris polvo.

TAPA:

cristal extra claro lacado color blanco, negro, gris grafito, gris polvo / MDF contrachapado en fresno blanqueado natural, gris, tabaco, marrón o lacado poro abierto color blanco, negro, gris grafito, gris polvo / Alucompact blanco o negro

Extensible table with base in ash wood, technical structure in aluminium. Top available in glass, MDF ash veneered, Alucompact.

STRUCTURE FINISHINGS:

bleached natural ash, grey, tobacco, dark brown or open pore lacquered in the colours white, black, graphite-like grey and dust-like grey.

TOP FINISHINGS:

extra clear glass lacquered in the colours white, black, graphite-like grey and dust-like grey / MDF ash veneered in the colours bleached natural ash, grey, tobacco, dark brown / open pore lacquered in the colours white, black, graphite-like grey, dust-like grey / Alucompact white or black.

cm 160 x 90 h 77
 cm 180 x 90 h 77
 cm 210 x 100 h 77
 cm 140 x 140 h 77

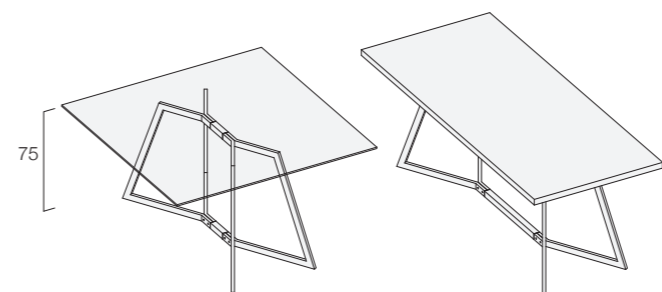

Tavolo con struttura in metallo laccato o cromo - satinato, piano in vetro o MDF impiallacciato frassino

FINITURA BASAMENTO:

metallo laccato bianco, nero, grigio grafite, cromo satinato.

FINITURA PIANO:

vetro extra chiaro temperato neutro / MDF impiallacciato frassino sbiancato naturale, tinto grigio, tinto tabacco, tinto moro o laccata poro aperto bianco, nero, grigio grafite, grigio polvere

Tisch mit lackierten oder satinierten-Chrom Metall Aufbau, und mit Glas oder furnierten Esche MDF Tischplatte.

STRUCTURE FINISHINGS:

weiß, schwarz, graphitgrau, lackierter Metall.

TOP FINISHINGS:

Extrahell weiß Glas / Naturgebleichte, graufarbige, tabakfarbene, schwarzfarbige furnierter Esche MDF oder weiß, schwarz, graphitgrau, staubgrau lackierte offene Pore Tischplatte.

Mesa con estructura en metal lacado o cromo satinado. Tapa en cristal o MDF contrachapado en fresno

ESTRUCTURA:

metal lacado colores blanco, negro, gris grafito.

TAPA:

cristal extra claro, MDF contrachapado en fresno blanqueado natural, gris, tabaco, marrón o lacado poro abierto color blanco, negro, gris grafito, gris polvo

Table with metal structure, lacquered or satin chrome. Top available in glass or MDF ash veneered.

STRUCTURE FINISHINGS:

metal lacquered in the colours white, black , graphite-like grey.

TOP FINISHINGS:

extra clear glass, MDF ash veneered in the colours bleached natural ash, grey, tobacco, dark brown / open pore lacquered in the colours white, black, graphite-like grey, dust-like grey

art. 12922 design Andrea Lucatello

HECTOR

cm 190 x 90 h 76
cm 220 x 100 h 76

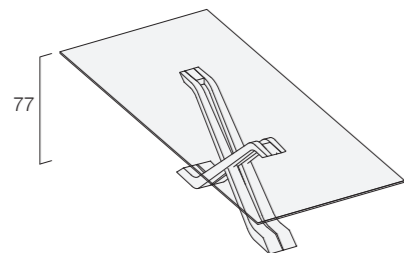

Tavolo con basamento in massello di frassino - piano in vetro

FINITURA BASAMENTO:

frassino sbiancato naturale, tinto grigio, tinto tabacco, tinto moro o laccato poro aperto bianco, nero, grigio grafite, grigio polvere.

FINITURA PIANO:

vetro neutro temperato extra chiaro

Tisch mit Kernholzesche Basis - Glas Tischplatte.

STRUCTURE FINISHINGS:

Naturgebleichte, graufarbige, tabakfarbene, schwarzfarbig Esche oder weiß, schwarz, graphitgrau, staubgrau lackierter offene Pore Aufbau.

TOP FINISHINGS:

neutral Extrahell Glas.

Mesa con base en madera de fresno. Tapa en cristal.

ESTRUCTURA:

fresno blanqueado natural, gris, tabaco, marron o lacado poro abierto color blanco, negro, gris grafito, gris polvo.

TAPA:

Tapa en cristal transparente extra claro

Table with solid ash wood; glass top

STRUCTURE FINISHINGS:

bleached natural ash, colours grey, tobacco, dark brown/ open pore lacquered in the colours white, black, graphite-like grey, dust-like grey

TOP FINISHINGS:

extra clear glass

art. 12915 design Stch Flai

MILO

Chiuso_Closed_Cerrado_Geschlossen / Aperto_Open_abierto_offen

cm 131 X 80 H 76 / cm 181 X 90 H 76
cm 156 X 80 H 76 / cm 206 X 80 H 76
cm 156 X 90 H 76 / cm 206 X 90 H 76 - cm 256 X 90 H 76
cm 176 X 90 H 76 / cm 226 X 90 H 76 - cm 276 X 90 H 76

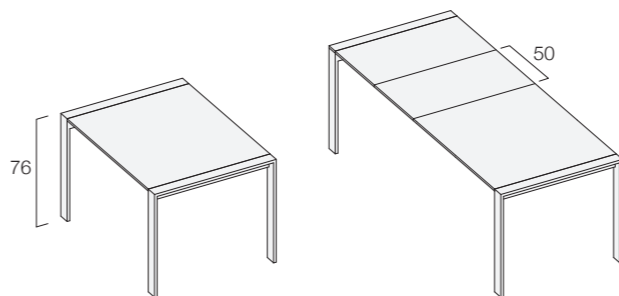

Tavolo allungabile con struttura in metallo e alluminio laccato, piano laminato, vetro, MDF impiallacciato frassino o Alucompact®

FINITURA BASAMENTO:

metallo laccato bianco, nero, grigio grafite, o grigio polvere.

FINITURA PIANO:

laminato (varianti come da campionario materiali), / vetro extra chiaro laccato bianco, nero, grigio grafite e grigio polvere / Alucompact® bianco o nero

Ausziehtisch mit Metall oder lackierten Aluminium Aufbau, Walztischplatte, Glas, furnierten Esche MDF oder Alucompact.

STRUCTURE FINISHINGS:

weiß, schwarz, graphitgrau, staubgrau lackierter Metall.

TOP FINISHINGS:

Walztischplatte (Varianten als im Werkstoffmusterbuch), Extrahell weiß, schwarz, graphitgrau und staubgrau Glas / weißer oder schwarzer Alucompact.

Mesa extensible con estructura en metal y aluminio lacado. Tapa en laminado, cristal, MDF contrachapado en fresno o Alucompact.

ESTRUCTURA:

metal lacado blanco, negro, gris grafito o gris polvo.

TAPA:

Tapa en laminado (en los variantes del muestrario)/ cristal extra claro lacado color blanco, negro, gris grafito, gris polvo/ Alucompact blanco o negro

Extensible table with structure in metal and aluminium lacquered. Top available in laminated, glass, MDF ash veneered, Alucompact

STRUCTURE FINISHINGS:

metal lacquered in the colours white, black, graphite-like grey and dust-like grey.

TOP FINISHINGS:

laminated (in the finishings as sample book), extra clear glass lacquered in the colours white, black, graphite-like grey and dust-like grey/ Alucompact white or black.

art. 12925 design Stch Flai

JONATHAN

Chiuso_Closed_Cerrado_Geschlossen / Aperto_Open_abierto_offen

cm 115 X 80 H 77 / cm 165 X 80 H 77
cm 140 X 80 H 77 / cm 190 X 80 H 77
cm 140 X 90 H 77 / cm 200 X 90 H 77
cm 160 X 90 H 77 / cm 220 X 90 H 77
cm 180 X 90 H 77 / cm 240 X 90 H 77

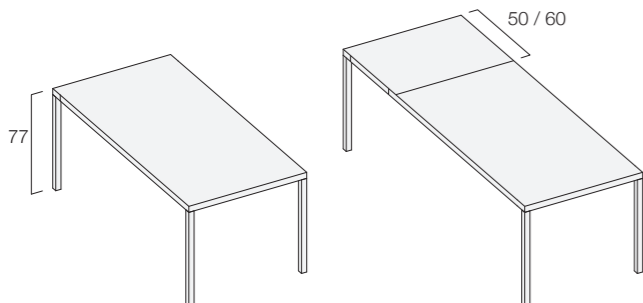

Tavolo allungabile con struttura in alluminio laccato o anodizzato, piano laminato, vetro, MDF impiallacciato frassino o Alucompact®

FINITURA BASAMENTO:

alluminio laccato bianco, nero, grigio grafite, grigio polvere o anodizzato.

FINITURA PIANO:

laminato (varianti come da campionario materiali), / vetro extra chiaro laccato bianco, nero, grigio grafite e grigio polvere / MDF impiallacciato frassino sbiancato naturale, tinto grigio, tinto tabacco, tinto moro o laccato poro aperto bianco, nero, grigio grafite, grigio polvere / Alucompact® bianco o nero

Ausziehtisch mit lackierten oder elaxierten Aluminium Aufbau, gewalzen Tischplatte, Glas furnierter Esche MDF oder Alucompact

BASIS:

weiß, schwarz, graphitgrau, staubgrau lackierter oder elaxierter Aluminium.

TISCHPLATTE:

Walztischplatte (Varianten als im Werkstoffmusterbuch), Extrahell weiß, schwarz, graphitgrau und staubgrau lackiertes Glas, Naturgebleichte, graufarbige, tabakfarbene, schwarzfarbige furnierte Esche MDF oder weiß, schwarz, graphitgrau, staubgrau lackierte offene Pore Tischplatte / weißer oder schwarzer Alucompact.

Mesa extensible con estructura en aluminio lacado o bien anodizado. Tapa en laminado, cristal, MDF contrachapado en fresno o Alucompact.

ESTRUCTURA:

aluminio lacado colores blanco, negro, gris grafito, gris polvo o anodizado.

TAPA:

laminado (en los variantes del muestrario) / cristal extra claro lacado color blanco, negro, gris grafito, gris polvo / MDF contrachapado en fresno blanqueado natural, gris, tabaco, marrón o lacado poro abierto color blanco, negro, gris grafito, gris polvo / Alucompact blanco o negro

Extensible table with aluminium or anodized lacquered structure. Top available in laminated, glass, MDF ash veneered, Alucompact

STRUCTURE FINISHINGS:

aluminium in the colours white, black, graphite-like grey, dust-like grey lacquered or anodized.

TOP FINISHINGS:

laminated (in the finishings as sample book)/ extra clear glass lacquered in the colours white, black, graphite-like grey and dust-like grey/ MDF ash veneered in the colours bleached natural ash, grey, tobacco, dark brown/ open pore lacquered in the colours white, black, graphite-like grey, dust-like grey/ Alucompact white or black.

art. 12919 design Stch Flai

PLINIO

Chiuso_Closed_Cerrado_Geschlossen / Aperto_Open_abierto_offen

cm 115 X 80 H 76 / cm 165 X 80 H 76
cm 140 X 80 H 76 / cm 190 X 80 H 76 - cm 240 X 80 H 76
cm 140 X 90 H 76 / cm 190 X 90 H 76 - cm 240 X 90 H 76
cm 160 X 90 H 76 / cm 210 X 90 H 76 - cm 260 X 90 H 76
cm 180 X 90 H 76 / cm 230 X 90 H 76 - cm 280 X 90 H 76

Ausziehtisch mit lackierten Aluminium Aufbau, Walztischplatte, Glas, furnierten Esche MDF oder Alucompact.

BASIS:

weiß, schwarz, graphitgrau, staubgrau lackierter oder elaxierter Aluminium.

TISCHPLATTE:

Walztischplatte (Varianten als im Werkstoffmusterbuch), Extrahell weiß, schwarz, graphitgrau und staubgrau lackiertes Glas / Naturgebleichte, graufarbige, tabakfarbene, schwarzfarbige furnierter Esche MDF oder weiß, schwarz, graphitgrau, staubgrau lackierte offene Pore Tischplatte / weißer oder schwarzer Alucompact.

Mesa extensible con estructura en aluminio lacado. Tapa en laminado, cristal, MDF contrachapado en fresno o Alucompact.

ESTRUCTURA:

aluminio lacado colores blanco, negro, gris grafito, gris polvo.

TAPA:

laminado (en los variantes del muestrario)/cristal extra claro lacado color blanco, negro, gris grafito, gris polvo / MDF contrachapado en fresno blanqueado natural, gris, tabaco, marrón o lacado poro abierto color blanco, negro, gris grafito, gris polvo / Alucompact blanco o negro

Extensible table with aluminium lacquered structure. Top available in laminated, glass, MDF ash veneered, Alucompact

STRUCTURE FINISHINGS:

aluminium in the colours white, black, graphite-like grey, dust-like grey lacquered or anodized.

TOP FINISHINGS:

laminated (in the finishings as sample book), extra clear glass lacquered in the colours white, black, graphite-like grey and dust-like grey/ MDF ash veneered in the colours bleached natural ash, grey, tobacco, dark brown/ open pore lacquered in the colours white, black, graphite-like grey, dust-like grey/ Alucompact white or black.

cm 220 x 100 h 76

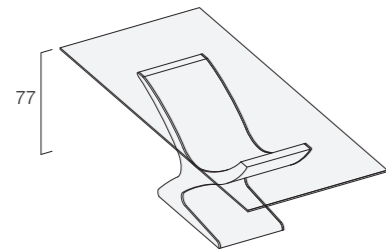

Tisch mit satinierten Stahl Basis oder mit Seiteneinheiten in lackierten Metall, Glas Tischplatte.

STRUCTURE FINISHINGS:

satiniertes Stahl oder mit Seiteneinheiten in weiß lackierten Metall.

TOP FINISHINGS:

neutral Extrahell Glas.

Mesa con base en acero satinado o con detalles laterales en metal lacado.
Tapa en cristal.

ESTRUCTURA:

acero satinado o con detalles laterales en metal lacado blanco.

TAPA:

Tapa en cristal transparente extra claro.

Table with base in steel, satin finishing or with lateral details in lacquered metal. Glass top.

STRUCTURE FINISHINGS:

satin steel or with lateral details in white lacquered metal.

TOP FINISHINGS:

extra clear glass.

Tavolo con basamento in acciaio satinato o con particolari laterali in metallo laccato, piano in vetro.

FINITURA BASAMENTO:

acciaio satinato o con particolari laterali in metallo laccato bianco.

FINITURA PIANO:

vetro neutro temperato extra chiaro

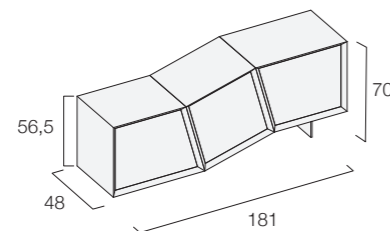
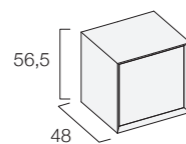

Anbaubacktrog mit matt lackierten MDF Aufbau und Türen in offene Pore furnierten Esche MDF, oder in glänzenden lackierten MDF.

AUFBAU:

matt weiß, matt schwarz, graphitgrau, beige lackierte.

TÜREN UND BRETTE:

Türen: glänzende lackierte in weiß, schwarz graphitgrau Farben, oder in schwarzfarbige, tabak, weiß, grau und schwarz offene Pore Esche. Brette: in neutral Extrahell Glas.

Estanteria componible con estructura en MDF lacado opaco y puertas contrachapadas en fresno poro abierto o mdf lacado brillante.

ESTRUCTURA:

lacada opaco en los colores blanco, negro, gris grafito.

PUERTAS Y ESTANTES:

Puertas: lacadas colores blanco, negro y gris grafito brillante o fresno poro abierto en los colores maron, tabacco, gris, blanco o negro. Estantes: cristal extra claro.

Cupboard system with MDF structure, matt colour lacquered. Doors in MDF ash veneered open pore or MDF glossy lacquered.

STRUCTURE FINISHINGS:

matt lacquered in the colours white, black, graphite-like grey.

DOORS AND SHELVES:

Doors: glossy lacquered in the colours white, black and graphite-like grey or ash wood open pore lacquered in the colours dark brown, tobacco, grey, black and white. Shelves: Extra clear glass.

Madia componibile con struttura in MDF laccato opaco e ante in MDF impiallacciate frassino poro aperto o in MDF laccato lucido.

FINITURA STRUTTURA:

Laccata bianco opaco, nero opaco, grigio grafito.

FINITURA ANTE E RIPIANI:

Ante: laccate lucido nei colori bianco, nero, grigio grafito oppure in frassino poro aperto tinto moro, tabacco, grigio, bianco e nero. Ripiani: Vetro neutro temperato extrachiaro.

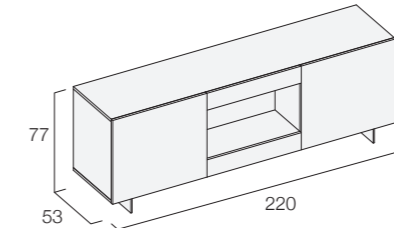

Madia con struttura in agglomerato di legno laccato. Ante impiallacciate frassino. Ante laterali a battente, parte centrale a cassetto con luce led per illuminare il vano a giorno. Basamento in metallo laccato.

FINITURA STRUTTURA:

Laccata bianco opaco, nero opaco, grigio grafito.

FINITURA ANTE E RIPIANI:

Ante: frassino poro aperto tinto moro, grigio, tabacco, bianco, nero, grigio grafito.
Ripiani: Vetro neutro temperato extrachairo

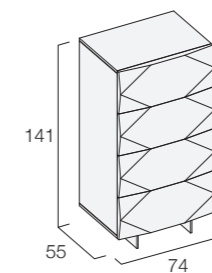
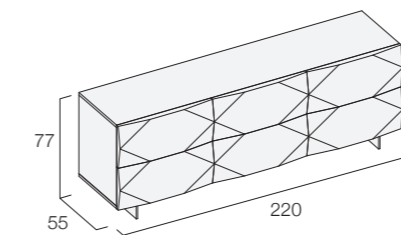
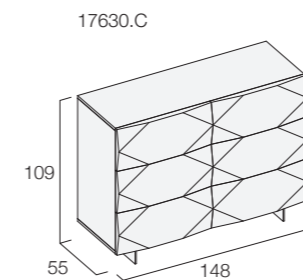

Backtrog mit lackierten Anhäufungholz Aufbau. Furnierte Esche Türen. Seitenflügeltüren, Mittelteil mit einer Schublade und mit Leuchtdiode Licht den Raum taghell zu erleuchten. Basis in lackierten Metall.

AUFBAU:

lackierte matt weiß, matt schwarz, graphitgrau.

TÜREN UND BRETTE:

Türen: schwarzfarbige, tabak, weiß, schwarz, graphitgrau offene Pore Esche. Brette: in neutral Extrahell Glas.

Aparador con estructura en aglomerado de madera lacado. Puertas contrachapadas en fresno. Puertas laterales batientes. Cajon central con sistema de luz LED. Base en metal lacado.

ESTRUCTURA:

lacada opaco en los colores blanco, negro, gris grafito.

PUERTAS E ESTANTES:

Puertas: fresno poro abierto colores marron, tabacco, blanco, negro, gris grafito. Estantes: cristal extra claro.

Cupboard with structure in agglomerated lacquered wood. Ash veneered doors. Lateral flap doors. Central drawer with LED lights system to light up the open space. Lacquered metal plinth.

STRUCTURE FINISHINGS:

matt lacquered in the colours white, black, graphite-like grey.

DOORS AND SHELVES:

Doors: ash wood, open pore lacquered in the colours dark brown, tobacco, white, black, graphite-like grey. Shelves: Extra clear glass.

Backtrog mit lackierten Anhäufungholz Aufbau. Furnierte Esche Türen. Seitenflügeltüren, Kassettemittelteil mit innerer Schublade. Basis in lackierten Metall.

AUFBAU:

lackierte matt weiß, matt schwarz, graphitgrau.

TÜREN UND BRETTE:

Türen: schwarzfarbige, tabak, weiß, schwarz, graphitgrau offene Pore Esche. Brette: in neutral Extrahell Glas.

Aparador con estructura en aglomerado de madera lacado. Puertas contrachapadas en fresno. Puertas laterales batientes. Cajon central con otro cajon al interior. Base en metal lacado.

ESTRUCTURA:

lacada opaco en los colores blanco, negro, gris grafito.

PUERTAS E ESTANTES:

Puertas: fresno poro abierto colores marron, tabacco, blanco, negro, gris grafito. Estantes: cristal extra claro.

Cupboard with structure in agglomerated lacquered wood. Ash veneered doors. Lateral flap doors. Central chest with a drawer inside. Lacquered metal plinth.

STRUCTURE FINISHINGS:

matt lacquered in the colours white, black, graphite-like grey.

DOORS AND SHELVES:

Doors: ash wood, open pore lacquered in the colours dark brown, tobacco, white, black, graphite-like grey. Shelves: Extra clear glass.

Madia con struttura in agglomerato di legno laccato. Ante impiallacciate frassino.

Ante laterali a battente, parte centrale a cassetto interno. Basamento in metallo laccato.

FINITURA STRUTTURA:

Laccata bianco opaco, nero opaco, grigio grafito.

FINITURA ANTE E RIPIANI:

Ante: frassino poro aperto tinto moro, grigio, tabacco, bianco, nero, grigio grafito.
Ripiani: Vetro neutro temperato extrachairo.

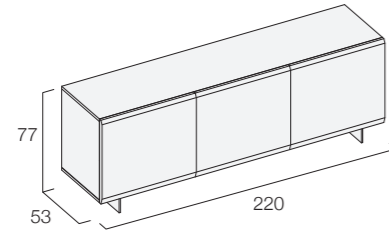

Madia con struttura in agglomerato di legno laccato opaco goffrato. Ante laccate lucido. Basamento in metallo laccato.

FINITURA STRUTTURA:

Laccata bianco opaco, nero opaco, grigio grafite.

FINITURA ANTE E RIPIANI:

Ante: laccate lucido nei colori bianco, nero, grigio grafite.
Ripiani: Vetro neutro extrachairo.

Backtrog mit gaufrierten matt lackierten Anhängenholz Aufbau. Glänzende lackierte Türen. Basis in lackierten Metall.

AUFBAU:

lackierte matt weiß, matt schwarz, graphitgrau, beige.

TÜREN UND BRETTE:

Türen: glänzende lackierte in weiß, schwarz, graphitgrau Farben.
Brette: in neutral Extrahell Glas.

Aparador con estructura en aglomerado de madera impresa, lacada color opaco. Puertas lacadas en color brillante. Base en metal lacado.

ESTRUCTURA:

lacada opaco en los colores blanco, negro, gris grafito.

PUERTAS E ESTANTES:

Puertas: lacadas colores blanco, negro, gris grafito brillante.
Estantes: cristal extra claro.

Cupboard with structure in agglomerated wood, matt colour lacquered, embossed. Glossy lacquered doors. Lacquered metal plinth.

STRUCTURE FINISHINGS:

matt lacquered in the colours white, black, graphite-like grey.

DOORS AND SHELVES:

Doors: glossy lacquered in the colours white, black, graphite-like grey.
Shelves: Extra clear glass

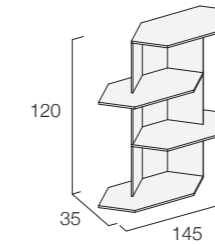

Bücherschränke in lackierten MDF.

AUFBAU:

matt rot, seilbeige, blau, schwarz, weiß, graphitgrau, oder staubgrau lackierter.

Estanteria en MDF lacado

ESTRUCTURA:

lacada opaca en los colores rojo, beige cuerda, azul, negro, blanco, gris grafito, gris polvo.

Bookcase MDF lacquered.

STRUCTURE FINISHINGS:

matt lacquered in the colours red, rope-like beige, blue, black, white, graphite-like grey, dust-like grey.

Elemento libreria in MDF laccato.

FINITURA STRUTTURA:

Laccata opaco rosso, beige corda, blu, nero, bianco, grigio grafite, grigio polvere.

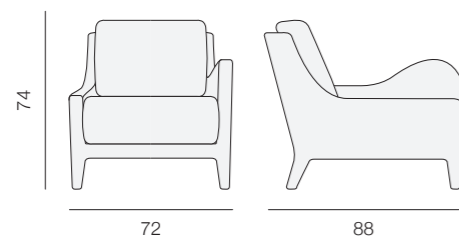

Sessel im Vollnarbenleder mit einem Arm positionierten am Recht oder am Links wie Anfrage des Kunden oder am beiden Seiten.

VARIANTEN AUFBAU:

Vollnarbenleder in den Farben als im Werkstoffmusterbuch.

Butaca tapizada en plena flor de piel con un apoyabrazos solo posicionable por la derecha o por la izquierda según la preferencia del cliente o de todas formas por ambos lados.

ACABADOS ESTRUCTURA:

Plena flor de piel en las variantes del muestrario

Armchair completely covered in full grain leather, with amrest which can be double or positioned only on the right or on the left side.

STRUCTURE FINISHINGS:

Full grain leather, in the colours proposed in the sample book.

Poltroncina rivestita in pelle pieno fiore con bracciolo singolo posizionabile a destra o sinistra secondo richiesta da ambo il lati.

FINITURA STRUTTURA:

Pelle - pieno fiore nei colori come da campionario materiali.

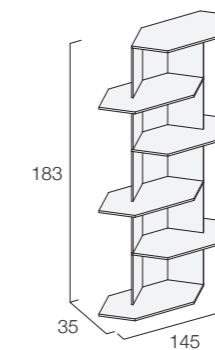

Bücherschränke in lackierten MDF.

AUFBAU:

matt rot, seilbeige, blau, schwarz, weiß, graphitgrau, oder staubgrau lackierter.

Estanteria en MDF lacado

ESTRUCTURA:

lacada opaca en los colores rojo, beige cuerda, azul, negro, blanco, gris grafito, gris polvo.

Bookcase MDF lacquered.

STRUCTURE FINISHINGS:

matt lacquered in the colours red, rope-like beige, blue, black, white, graphite-like grey, dust-like grey.

Elemento libreria in MDF laccato.

FINITURA STRUTTURA:

Laccata opaco rosso, beige corda, blu, nero, bianco, grigio grafite, grigio polvere.

art. 11153 design Stch Flai **BETTA**

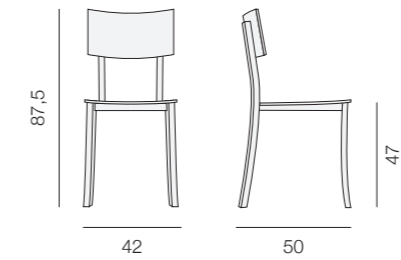

Sedia con struttura in metallo laccato, seduta e schienale in multistrati di legno essenza di frassino o laminato.

FINITURA STRUTTURA:
metallo laccato bianco, nero, grigio grafite o grigio polvere.

FINITURA RIVESTIMENTO:
frassino sbiancato naturale, tinto grigio, tinto tabacco, tinto moro o laccato poro aperto bianco, nero, grigio grafite, grigio polvere o laminato nei colori come da campionario

Stuhl mit lackierten Metall Aufbau, Sitzung und Rückenlehne im vielschichtigen Esche Holzweesen oder Walzstücke.

AUFBAU:
weiß, schwarz, graphitgrau oder staubgrau lackierter Metall.

SITZUNG UND RÜCKENLEHNE:
Sitzung und Rückenlehne: in Naturgebleichte, graufarbige, tabakfarbene, schwarzfarbige Esche oder weiß, schwarz, graphitgrau, staubgrau lackierte offene Pore, oder in Walzstücke als in den Farben im Werkstoffmusterbuch.

Silla con estructura en metal lacado, asiento y respaldo en multicapas de madera de fresno o laminado

ESTRUCTURA:
metal lacado blanco, negro, gris grafito o gris polvo.

ASIENTO:
Asiento y respaldo: fresno blanqueado natural, gris, tabaco, marrón o lacado poro abierto color blanco, negro, gris grafito, gris polvo o laminado en los colores del muestrario.

Chair with lacquered metal structure, with multilayer ash wood seat and back, or laminated

STRUCTURE FINISHINGS:
metal lacquered in the colours white, black, graphite-like grey or dust-like grey.

COVERING FINISHINGS:
Seat and back: bleached natural ash, colours grey, tobacco, dark brown or open pore lacquered in the colours white, black, graphite-like grey, dust-like grey or laminated in the colours as sample book.

art. 11122 design Stefano Cavazzana **DOWNY**

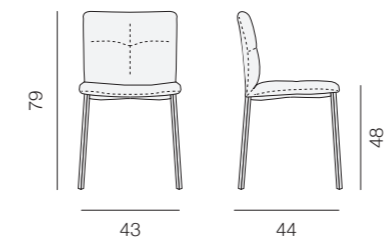

Sedia con struttura in metallo laccato, seduta in tecnopolimero rivestita in pelle - ecopelle - tessuto

FINITURA STRUTTURA:
metallo laccato bianco, nero, grigio grafite o grigio polvere

FINITURA RIVESTIMENTO:
rivestimento in pelle, eco-pelle o tessuto come da campionario materiali

Stuhl mit lackierten Metall, Technopolymere Sitzung verkleidete mit Leder - Ökoleder - Stoff.

AUFBAU:
weiß, schwarz, graphitgrau oder staubgrau lackierter Metall.

SITZUNG:
Verkleidung als im Werkstoffmusterbuch.

silla con estructura en metal lacado, asiento en tecnopolimero tapizado en piel, ecopiel, tejido

ESTRUCTURA:
metal lacado blanco, negro, gris grafito o gris polvo.

ASIENTO:
tapizado en los variantes del muestrario

Chair with lacquered metal structure, propylene seat covered in leather, eco-leather or fabric.

STRUCTURE FINISHINGS:
metal lacquered in the colours white, black, graphite-like grey or dust-like grey.

COVERING FINISHINGS:
Seat covered with materials as sample book.

art. 11123 design Stefano Cavazzana **DOWNY WOOD**

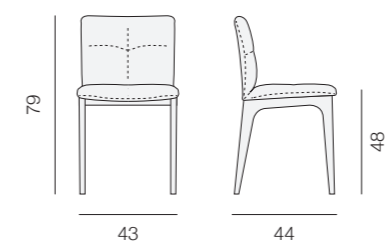

Sedia con struttura in frassino, seduta in tecnopolimero rivestita in pelle - ecopelle - tessuto

FINITURA STRUTTURA:
frassino sbiancato naturale, tinto grigio, tinto tabacco, tinto moro o laccato poro aperto bianco, nero, grigio grafite, grigio polvere.

FINITURA RIVESTIMENTO:
rivestimento in pelle, eco-pelle o tessuto come da campionario materiali

Stuhl mit Esche Aufbau, Technopolymere Sitzung verkleidete mit Leder Ökoleder - Stoff.

AUFBAU:
Naturgebleichte, graufarbige, tabakfarbene, schwarzfarbige Esche oder weiß, schwarz, graphitgrau, staubgrau lackierter offene Pore Aufbau.

SITZUNG UND RÜCKENLEHNE:
Verkleidung als im Werkstoffmusterbuch.

Silla con estructura en fresno, asiento en tecnopolimero tapizado en piel, eco-piel, tejido.

ESTRUCTURA:
fresno blanqueado natural, gris, tabaco, marrón o lacado poro abierto color blanco, negro, gris grafito, gris polvo.

ASIENTO:
tapizado en los variantes del muestrario.

Chair with ash wood structure, propylene seat covered in leather, eco-leather or fabric.

STRUCTURE FINISHINGS:
bleached natural ash, grey, tobacco, dark brown or open pore lacquered in the colours white, black, graphite-like grey, dust-like grey.

COVERING FINISHINGS:
covered with materials as sample book.

art. 11161 design Stch Flai **ELOISA**

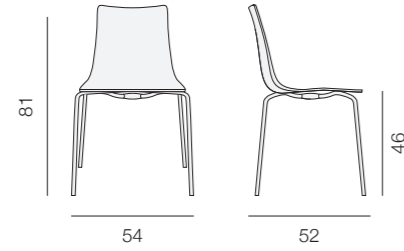

Sedia con struttura in metallo laccato, seduta in policarbonato

FINITURA STRUTTURA:
metallo laccato bianco, nero, grigio grafite o grigio polvere.

FINITURA SEDUTA:
policarbonato rosso, bianco o nero.

Stuhl mit lackierten Metall Aufbau, Sitzung in Polykarbonat.

AUFBAU:
weiß, schwarz graphitgrau oder staubgrau lackierter Metall.

SITZUNG:
in rot, weiß oder schwarz Polykarbonate.

Silla con estructura en metal lacado, asiento en policarbonato.

ESTRUCTURA:
metal lacado blanco, negro, gris grafito o gris polvo.

ASIENTO:
policarbonato rojo, blanco o negro.

Chair with lacquered metal structure, polycarbonate seat.

STRUCTURE FINISHINGS:
metal lacquered in the colours white, black, graphite-like grey, dust-like grey.

SEAT FINISHINGS:
polycarbonate in the colours red, white or black.

art. 11155 design Stch Flai **FRIDA STOOL**

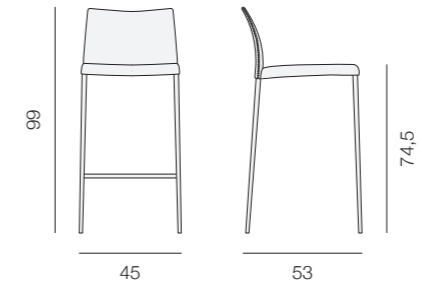

Sgabello con struttura in metallo laccato o cromo-satinato, seduta e schienale rivestiti in pelle - ecopelle - tessuto

FINITURA STRUTTURA:
metallo laccato bianco, nero, grigio grafite, grigio polvere o cromo-satinato.

FINITURA SEDUTA:
rivestimento come da campionario materiali.

art. 11145 design dm design **ISIDE**

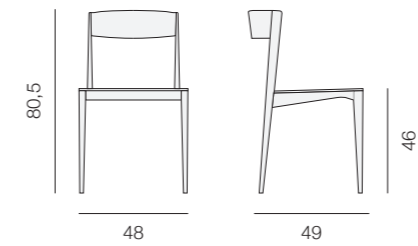

Sedia con struttura in frassino, seduta in multistrati di legno essenza di frassino o rivestita in pelle - ecopelle - tessuto o impagliata.

FINITURA STRUTTURA:
frassino sbiancato naturale, tinto grigio, tinto tabacco, tinto moro o laccata poro aperto bianco, nero, grigio grafite, grigio polvere.

FINITURA SEDUTA:
frassino o impagliata o rivestita con materiali come da campionario

art. 11146 design dm design **ISIDE CHIEF**

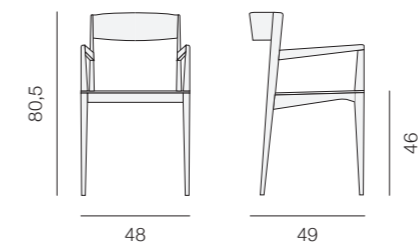

Sedia con struttura in frassino, seduta in multistrati di legno essenza di frassino o rivestita in pelle - ecopelle - tessuto o impagliata.

FINITURA STRUTTURA:
frassino sbiancato naturale, tinto grigio, tinto tabacco, tinto moro o laccata poro aperto bianco, nero, grigio grafite, grigio polvere.

FINITURA SEDUTA:
frassino o impagliata o rivestita con materiali come da campionario

Hocker mit lackierten oder satinierten-Chrom Metall Aufbau, Sitzung und Rückenlehne verkleidete mit Leder - Ökoleder - Stoff.

AUFBAU:
weiß, schwarz, graphitgrau, staubgrau lackierter oder satiniertes-Chrom Metall.

SITZUNG:
Verkleidung als im Werkstoffmusterbuch.

taburete con estructura en metal lacado o cromo satinado. Asiento y respaldo tapizados en piel, ecopiel, tejido

ESTRUCTURA:
metal lacado blanco, negro, gris grafito, gris polvo o cromo satinado.

ASIENTO:
tapizado en los variantes del muestrario.

Stool with lacquered metal or satin chrome structure, seat and back covered with leather, eco-leather or fabric.

STRUCTURE FINISHINGS:
metal lacquered in the colours white, black, graphite-like grey, dust-like grey or satin chrome.

SEAT FINISHINGS:
covered with materials as sample book.

art. 11150 design Stch Flai **FRIDA**

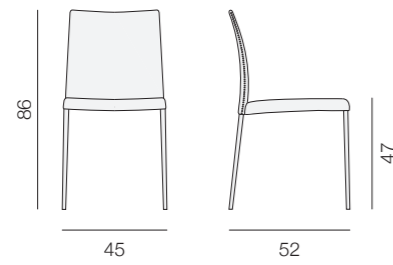

Stuhl mit lackierten oder satinierten-Chrom Metall Aufbau, Sitzung und Rückenlehne verkleidete mit Leder - Ökoleder - Stoff.

AUFBAU:
weiß, schwarz, graphitgrau, staubgrau lackierter oder satiniertes-Chrom Metall.

SITZUNG:
Verkleidung als im Werkstoffmusterbuch.

Silla con estructura en metal lacado o cromo satinado. Asiento y respaldo tapizados en piel, ecopiel, tejido.

ESTRUCTURA:
metal lacado blanco, negro, gris grafito, gris polvo o cromo satinado.

ASIENTO:
tapizado en los variantes del muestrario.

Chair with lacquered metal or satin chrome structure, seat and back covered with leather, eco-leather of fabric.

STRUCTURE FINISHINGS:
metal lacquered in the colours white, black, graphite-like grey, dust-like grey or satin chrome.

SEAT FINISHINGS:
Seat covered with materials as sample book.

Stuhl mit Esche Aufbau, Sitzung im vielschichtigen Esche Holzwesen oder verkleidete mit Leder - Ökoleder - Stoff; also geflochtener Stuhl.

AUFBAU:
Naturgebleichte, graufarbige, tabakfarbene, schwarzfarbige Esche oder weiß, schwarz, graphitgrau, staubgrau lackierte offene Pore.

SITZUNG:
in Esche, mit Stroh umwickelt oder verkleidete mit Werkstoffe als im Musterbuch.

Silla con estructura en fresno, asiento en multicapas de madera de fresno o tapizado en piel, ecopiel, tejido o empajado

ESTRUCTURA:
fresno blanqueado natural, gris, tabaco, marrón o lacado poro abierto color blanco, negro, gris grafito, gris polvo.

ASIENTO:
fresno o empajado o en los variantes del muestrario.

Chair with ash wood structure, multilayer ash wood seat or covered with leather, eco-leather, fabric or straw

STRUCTURE FINISHINGS:
bleached natural ash wood, grey, tobacco, dark brown or open pore lacquered in the colours white, black, graphite-like grey, dust-like grey.

SEAT FINISHINGS:
ash wood, or covered with straw, or with materials as sample book.

art. 11149 design Stch Flai **FRIDA MAX**

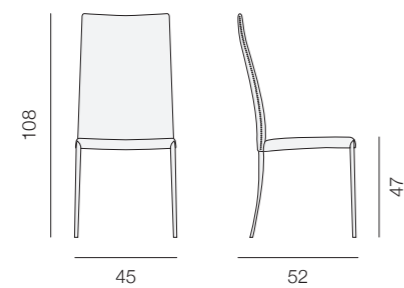

Sedia con struttura in metallo laccato o cromo-satinato, seduta e schienale rivestiti in pelle - ecopelle - tessuto.

FINITURA STRUTTURA:
metallo laccato bianco, nero, grigio grafite, grigio polvere o cromo-satinato.

FINITURA SEDUTA:
rivestimento come da campionario materiali.

Stuhl mit lackierten oder satinierten-Chrom Metall Aufbau, Sitzung und Rückenlehne verkleidete mit Leder - Ökoleder - Stoff.

AUFBAU:
weiß, schwarz, graphitgrau, staubgrau lackierter oder satiniertes-Chrom Metall.

SITZUNG:
Verkleidung als im Werkstoffmusterbuch.

Silla con estructura en metal lacado o cromo satinado. Asiento y respaldo tapizados en piel, ecopiel, tejido

ESTRUCTURA:
metal lacado blanco, negro, gris grafito, gris polvo o cromo satinado.

ASIENTO:
tapizado en los variantes del muestrario.

Chair with lacquered metal or satin chrome structure, seat and back covered with leather, eco-leather of fabric.

STRUCTURE FINISHINGS:
metal lacquered in the colours white, black, graphite-like grey, dust-like grey or satin chrome.

SEAT FINISHINGS:
covered with materials as sample book.

Stuhl mit Esche Aufbau, Sitzung im vielschichtigen Esche Holzwesen oder verkleidete mit Leder - Ökoleder - Stoff; also geflochtener Stuhl.

AUFBAU:
Naturgebleichte, graufarbige, tabakfarbene, schwarzfarbige Esche oder weiß, schwarz, graphitgrau, staubgrau lackierte offene Pore.

SITZUNG:
in Esche, mit Stroh umwickelt oder verkleidete mit Werkstoffe als im Musterbuch.

Silla con estructura en fresno, asiento en multicapas de madera de fresno o tapizado en piel, ecopiel, tejido o empajado

ESTRUCTURA:
fresno blanqueado natural, gris, tabaco, marrón o lacado poro abierto color blanco, negro, gris grafito, gris polvo.

ASIENTO:
fresno o empajado o en los variantes del muestrario.

Chair with ash wood structure, multilayer ash wood seat or covered with leather, eco-leather, fabric or straw

STRUCTURE FINISHINGS:
bleached natural ash wood, grey, tobacco, dark brown or open pore lacquered in the colours white, black, graphite-like grey, dust-like grey.

SEAT FINISHINGS:
ash wood, or covered with straw, or with materials as sample book.

art. 11137 design Stch Flai **MAGDA**

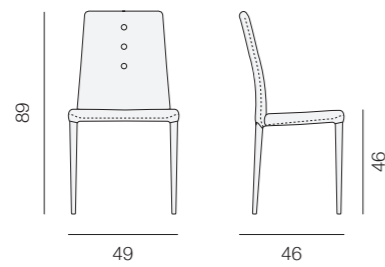

Sedia con struttura in metallo completamente rivestita in pelle o ecopelle.
RIVESTIMENTO:
pelle o ecopelle come da campionario materiali.

Stuhl mit Metall Aufbau völlig verkleidete mit Leder oder Ökoleder.
VERKLEIDUNG:
Leder oder Ökoleder als im Werkstoffmusterbuch.

Silla con estructura en metal, tapizada completamente en piel o ecopiel.
ESTRUCTURA:
Tapizada en piel o ecopiel en los colores del muestrario

Chair with metal structure, entirely covered in leather or eco-leather.
COVERED FINISHINGS:
Covered with leather or eco-leather as sample book.

art. 11157 design Stch Flai **MAILA**

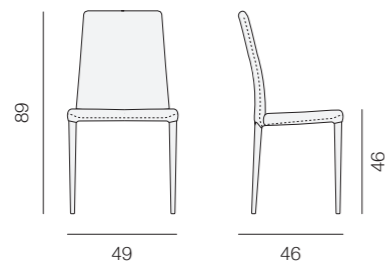

Sedia con struttura in metallo completamente rivestita in pelle o ecopelle.
RIVESTIMENTO:
pelle o ecopelle come da campionario materiali.

Stuhl mit Metall Aufbau völlig verkleidete mit Leder oder Ökoleder.
VERKLEIDUNG:
Leder oder Ökoleder als im Werkstoffmusterbuch.

Silla con estructura en metal, tapizada completamente en piel o ecopiel.
ESTRUCTURA:
Tapizada en piel o ecopiel en los colores del muestrario

Chair with metal structure, entirely covered in leather or eco-leather.
COVERED FINISHINGS:
Covered with leather or eco-leather as sample book.

art. 11144 design dm design **PETRA**

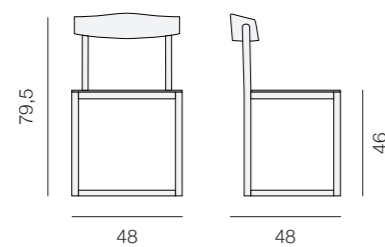

Sedia con struttura in frassino, seduta in multistrati di legno essenza di frassino o rivestita in pelle - ecopelle - tessuto o impagliata.

FINITURA STRUTTURA:
frassino sbiancato naturale, tinto grigio, tinto tabacco, tinto moro o laccata poro aperto bianco, nero, grigio grafite, grigio polvere.

FINITURA SEDUTA:
frassino o impagliata o rivestita con materiali come da campionario.

Stuhl mit Esche Aufbau, Sitzung im vielschichtigen Esche Holzwesen oder verkleidete mit Leder - Ökoleder - Stoff; also geflochtener Stuhl.

AUFBAU:
Naturgebleichte, graufarbige, tabakfarbene, schwarzfarbige Esche oder weiß, schwarz, graphitgrau, staubgrau lackierte offene Pore.

SITZUNG:
in Esche, mit Stroh umwickelt oder verkleidete mit Werkstoffe als im Musterbuch.

Silla con estructura en fresno, asiento en multicapas de madera de fresno o tapizado en piel, ecopiel, tejido, o empajado.

ESTRUCTURA:
fresno blanqueado natural, gris, tabaco, marrón o lacado poro abierto color blanco, negro, gris grafito, gris polvo.

ASIENTO:
fresno o empajado o tapizado en los materiales del muestrario.

Chair with ash wood structure, multilayer ash wood seat or covered with leather, eco-leather, fabric or straw.

STRUCTURE FINISHINGS:
bleached natural ash wood, colours grey, tobacco, dark brown or open pore lacquered in the colours white, black, graphite-like grey, dust-like grey.

SEAT FINISHINGS:
ash wood, or covered with straw, or with materials as sample book.

art. 11152 design Andrea Lucatello **SLEDGE**

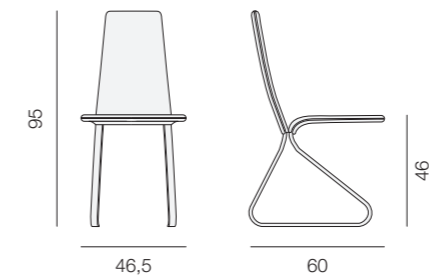

Sedia con struttura in metallo laccato, seduta e schienale rivestiti in pelle ecopelle - tessuto.

FINITURA STRUTTURA:
metallo laccato bianco, nero, grigio grafite, grigio polvere.

FINITURA SEDUTA:
rivestimento come da campionario materiali.

Stuhl mit lackierten oder satinierten-Chrom Metall, Sitzung und Rückenlehne verkleidete mit Leder - Ökoleder - Stoff.

AUFBAU:
weiß, schwarz, graphitgrau, staubgrau lackierter oder satinierter-Chrom Metall.

SITZUNG:
Verkleidung als im Werkstoffmusterbuch.

Silla con estructura en metal lacado o cromo satinado. Asiento y respaldo tapizados en piel, ecopiel, tejido

ESTRUCTURA:
metal lacado blanco, negro, gris grafito, gris polvo o cromo satinado. Asiento: tapizado en los materiales del muestrario.

ASIENTO:
tapizado en los variantes del muestrario.

Chair with lacquered metal or satin chrome structure, seat and back covered with leather, eco-leather or fabric.

STRUCTURE FINISHINGS:
metal lacquered in the colours white, black, graphite-like grey, dust-like grey or satin chrome.

SEAT FINISHINGS:
Seat covered with materials as sample book.

art. 11151 design Andrea Lucatello **SLEDGE MAXI**

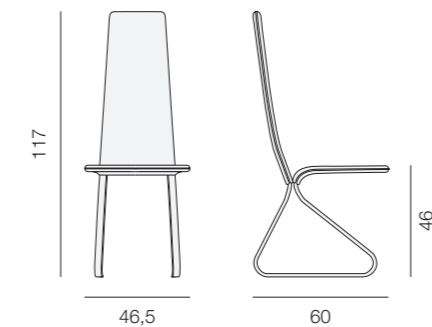

Sedia con struttura in metallo laccato, seduta e schienale rivestiti in pelle ecopelle - tessuto.

FINITURA STRUTTURA:
metallo laccato bianco, nero, grigio grafite, grigio polvere.

FINITURA SEDUTA:
rivestimento come da campionario materiali.

Stuhl mit lackierten oder satinierten-Chrom Metall, Sitzung und Rückenlehne verkleidete mit Leder - Ökoleder - Stoff.

AUFBAU:
weiß, schwarz, graphitgrau, staubgrau lackierter oder satinierter-Chrom Metall.

SITZUNG:
Verkleidung als im Werkstoffmusterbuch.

Silla con estructura en metal lacado o cromo satinado. Asiento y respaldo tapizados en piel, ecopiel, tejido

ESTRUCTURA:
metal lacado blanco, negro, gris grafito, gris polvo o cromo satinado. Asiento: tapizado en los materiales del muestrario.

ASIENTO:
tapizado en los variantes del muestrario.

Chair with lacquered metal or satin chrome structure, seat and back covered with leather, eco-leather or fabric.

STRUCTURE FINISHINGS:
metal lacquered in the colours white, black, graphite-like grey, dust-like grey or satin chrome.

SEAT FINISHINGS:
Seat covered with materials as sample book.

art. 11132 design Archirivolto **VELIA**

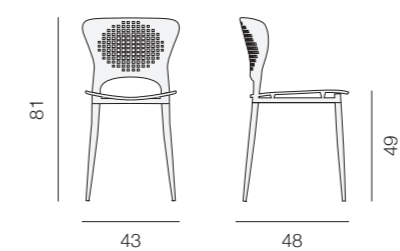

Sedia con struttura in metallo laccato o cromo-satinato, seduta e schienale in nylon lucido.

FINITURA STRUTTURA:
metallo laccato bianco, nero, rosso, giallo, arancio, viola, azzurro e beige.

FINITURA SEDUTA E SCHIENALE:
nylon bianco, nero, rosso, giallo, arancio, viola, azzurro e beige.

Stuhl mit lackierten oder satinierte-Chrom Aufbau, Sitzung und Rückenlehne im glänzenden Nylon.

AUFBAU:
weiß, schwarz, rot, gelb, orange, veichenfarben, blau und beige lackierter Metall.

SITZUNG UND RÜCKENLEHNE:
weiß, schwarz, rot, gelb, orange, veichenfarben, blau und beige Nylon.

Silla con estructura en metal lacado o cromo satinado. Asiento y respaldo en nailon brillante.

ESTRUCTURA:
metal lacado blanco, negro, rojo, amarillo, naranja, violeta, azul, beige.

ASIENTO Y RESPALDO:
nailon blanco, negro, rojo, amarillo, naranja, violeta, azul, beige.

Chair with lacquered metal or satin chrome structure, seat and back in glossy nylon.

STRUCTURE FINISHINGS:
metal lacquered in the colours white, black, red, yellow, orange, violet, light blue and beige.

SEAT AND BACK FINISHINGS:
nylon white, black, red, yellow, orange, violet, light blue and beige.

Finito di stampare
06_2011

FLAI

FLAI SRL

via martiri della libertà 18
35016 piazzola sul Brenta
Padova Italy
T +39 049 5590866
F +39 049 5590145
info@flaiweb.com
www.flaiweb.it